



US010556713B2

(12) **United States Patent**
Langen

(10) **Patent No.:** **US 10,556,713 B2**
(45) **Date of Patent:** **Feb. 11, 2020**

(54) **METHOD AND SYSTEM FOR ORDER FULFILMENT**

(71) Applicant: **H. J. Paul Langen**, Brampton (CA)

(72) Inventor: **H. J. Paul Langen**, Brampton (CA)

(*) Notice: Subject to any disclaimer, the term of this patent is extended or adjusted under 35 U.S.C. 154(b) by 0 days.

(21) Appl. No.: **16/230,979**

(22) Filed: **Dec. 21, 2018**

(65) **Prior Publication Data**

US 2019/0127099 A1 May 2, 2019

Related U.S. Application Data

(63) Continuation of application No. 14/644,842, filed on Mar. 11, 2015, now abandoned.

(Continued)

(51) **Int. Cl.**

- B65B 43/26** (2006.01)
- B65B 43/14** (2006.01)
- G06Q 10/08** (2012.01)
- G06Q 30/06** (2012.01)
- B65G 57/22** (2006.01)
- B65B 61/26** (2006.01)
- G06Q 50/28** (2012.01)

(52) **U.S. Cl.**

CPC **B65B 43/265** (2013.01); **B65B 43/145** (2013.01); **B65B 61/26** (2013.01); **B65G 57/22** (2013.01); **G06Q 10/08** (2013.01); **G06Q 10/087** (2013.01); **G06Q 30/0635** (2013.01); **G06Q 50/28** (2013.01)

(58) **Field of Classification Search**

CPC B65B 61/26; B65B 43/265; B65B 43/145
See application file for complete search history.

(56) **References Cited**

U.S. PATENT DOCUMENTS

4,553,954 A 11/1985 Sewell et al.
5,145,070 A * 9/1992 Pallett B65D 5/5004
206/521

(Continued)

FOREIGN PATENT DOCUMENTS

EP 1177980 A2 2/2002
WO 2013/142106 A1 9/2013

OTHER PUBLICATIONS

International Search Report issued by the Canadian Intellectual Property Office dated Jun. 27, 2013 in connection with International PCT Patent Application No. PCT/CA2013/000245 filed on Mar. 15, 2013, 5 pages.

(Continued)

Primary Examiner — Thomas Randazzo

(57) **ABSTRACT**

A method of fulfilling an order comprising at least one product is provided. The method includes receiving an order comprising at least one product, determining a suitable case from a plurality of available cases for holding the at least one product, said determining being a function of one or more characteristics of each product of the at least one product and one or more characteristics of the plurality of available cases; forwarding information identifying the suitable case to a case former; providing a case blank corresponding to said suitable case to said case former; erecting a suitable case from said case blank corresponding to said suitable case with said case former; and prior to the loading said suitable case with said at least one product, labelling said suitable case with at least one label.

19 Claims, 70 Drawing Sheets

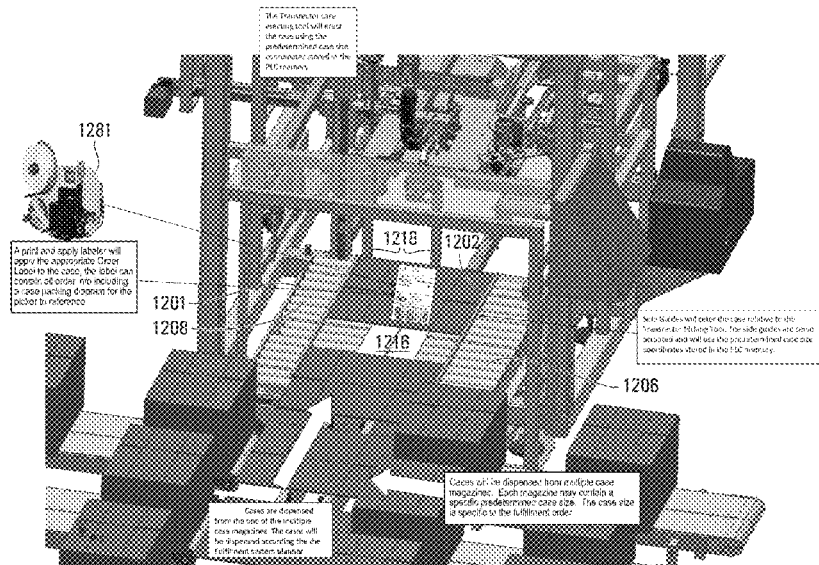

Related U.S. Application Data

(60) Provisional application No. 61/951,263, filed on Mar. 11, 2014.

References Cited

U.S. PATENT DOCUMENTS

5,456,570 A * 10/1995 Davis, Jr. B65G 47/915
271/107
6,032,853 A * 3/2000 Chevalier B65D 5/241
229/125.37
6,378,275 B1 * 4/2002 Andersson B65B 3/326
53/458
6,688,075 B2 * 2/2004 Cristina B65B 59/00
53/201
6,721,762 B1 * 4/2004 Levine G06Q 10/04
6,764,436 B1 7/2004 Mazurek
6,876,958 B1 4/2005 Chowdhury et al.
8,340,812 B1 12/2012 Tian et al.
8,622,883 B2 * 1/2014 Flynn B65D 5/62
493/51
8,671,654 B2 * 3/2014 Langen B65D 5/20
493/122
8,961,380 B2 * 2/2015 Langen B65D 5/20
493/127
9,061,477 B2 * 6/2015 Chandaria B65D 5/3621
9,315,344 B1 * 4/2016 Lehmann G06Q 10/08
9,714,145 B1 * 7/2017 Lehmann G06Q 10/08
2003/0200111 A1 * 10/2003 Damji G06Q 10/08
705/335
2004/0112520 A1 * 6/2004 Hanschen B65C 9/1803
156/277
2006/0277269 A1 * 12/2006 Dent G06Q 50/24
709/217

2007/0038673 A1 * 2/2007 Broussard G06Q 10/08
2007/0072755 A1 3/2007 Monti
2007/0197364 A1 * 8/2007 Monti B65B 43/305
493/316
2008/0067225 A1 * 3/2008 Moore B65B 5/028
229/194
2009/0319395 A1 * 12/2009 Chandaria B65D 5/3621
705/26.1
2011/0297559 A1 * 12/2011 Davis B65B 25/008
206/5.1
2013/0218799 A1 * 8/2013 Lehmann G06Q 10/083
705/337
2013/0247519 A1 9/2013 Clark et al.
2015/0225104 A1 * 8/2015 Reed B65C 1/028
347/110
2015/0324893 A1 * 11/2015 Langen G06Q 30/0635
705/26.81

OTHER PUBLICATIONS

Written Opinion of the International Searching Authority issued by the Canadian Intellectual Property Office dated Jun. 27, 2013 in connection with International PCT Patent Application No. PCT/CA2013/000245 filed on Mar. 15, 2013, 6 pages.
International Preliminary Report on Patentability issued by the International Bureau of WIPO dated Oct. 28, 2014 in connection with International PCT Patent Application No. PCT/CA2013/000245 filed on Mar. 15, 2013, 7 pages.
XPAK USA, LLC, XPAK ROBOX™—Robotic Random-Size Box Erector Brochure, <http://www.xpakusa.com/pdf/XPAK%20-%20ROBOX%20Robotic%20Case%20Erector%20Model%20XP-E3000R.pdf> (last printed Mar. 22, 2016).

* cited by examiner

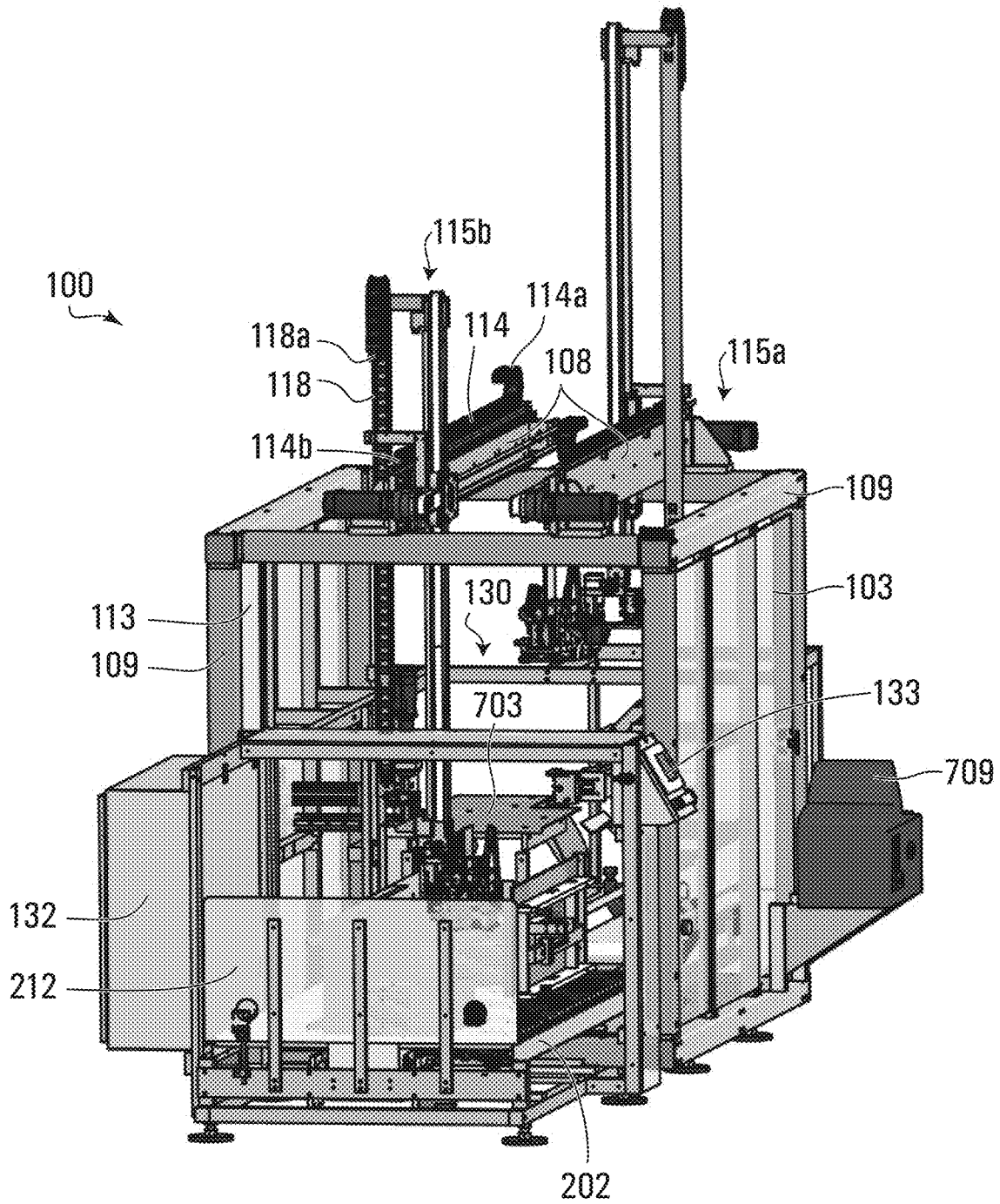

FIG. 1A

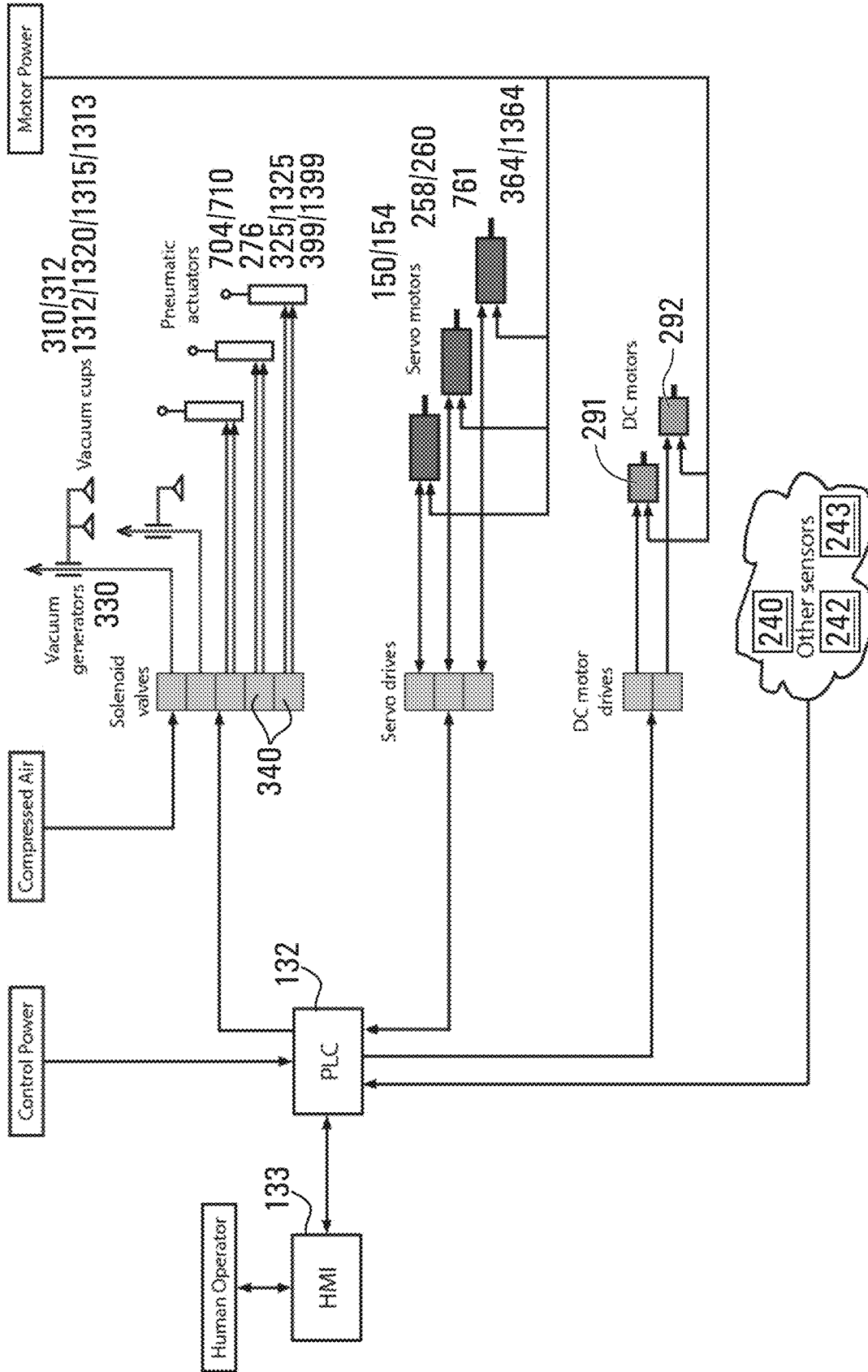

FIG. 1B

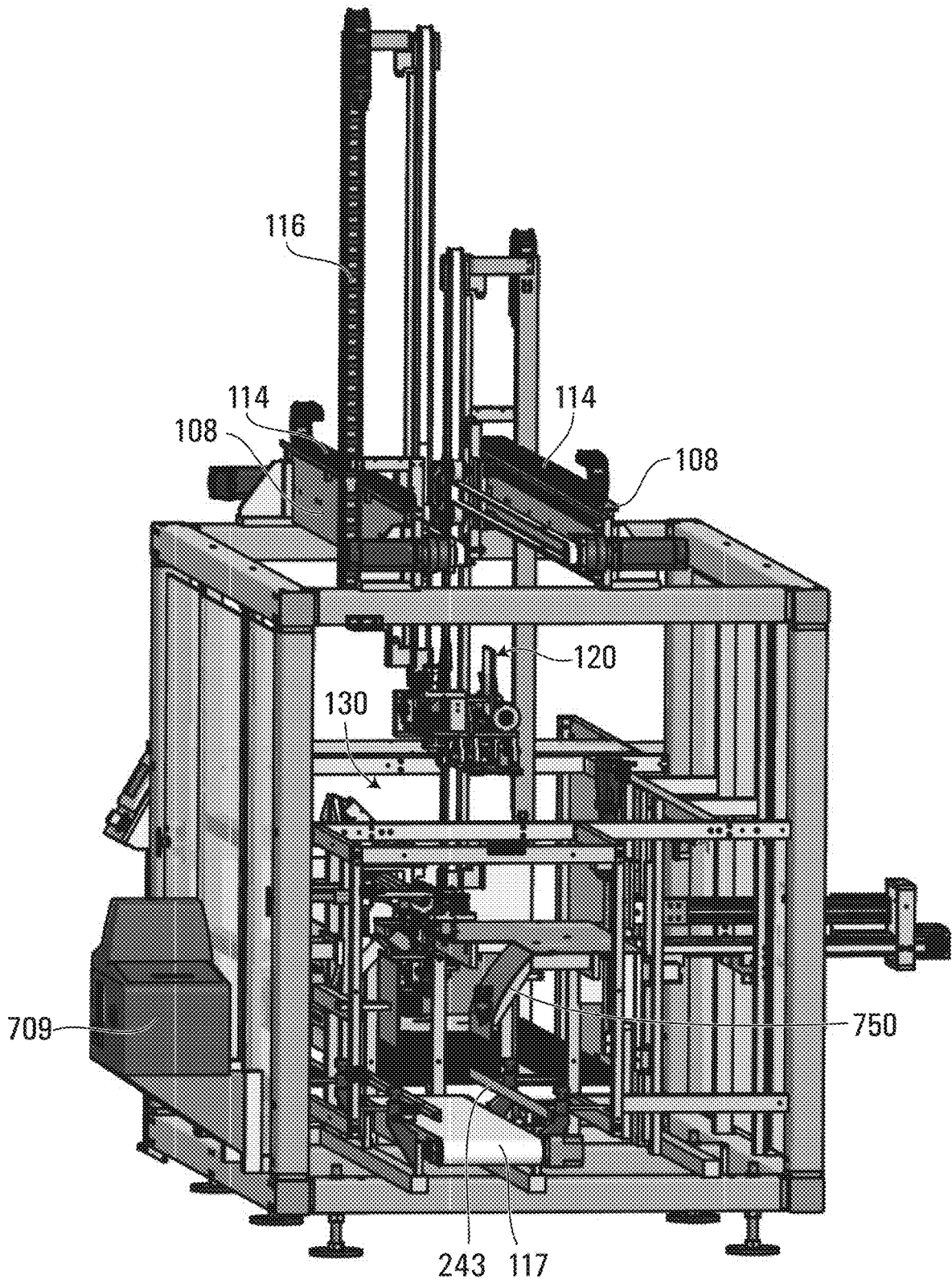

FIG. 2

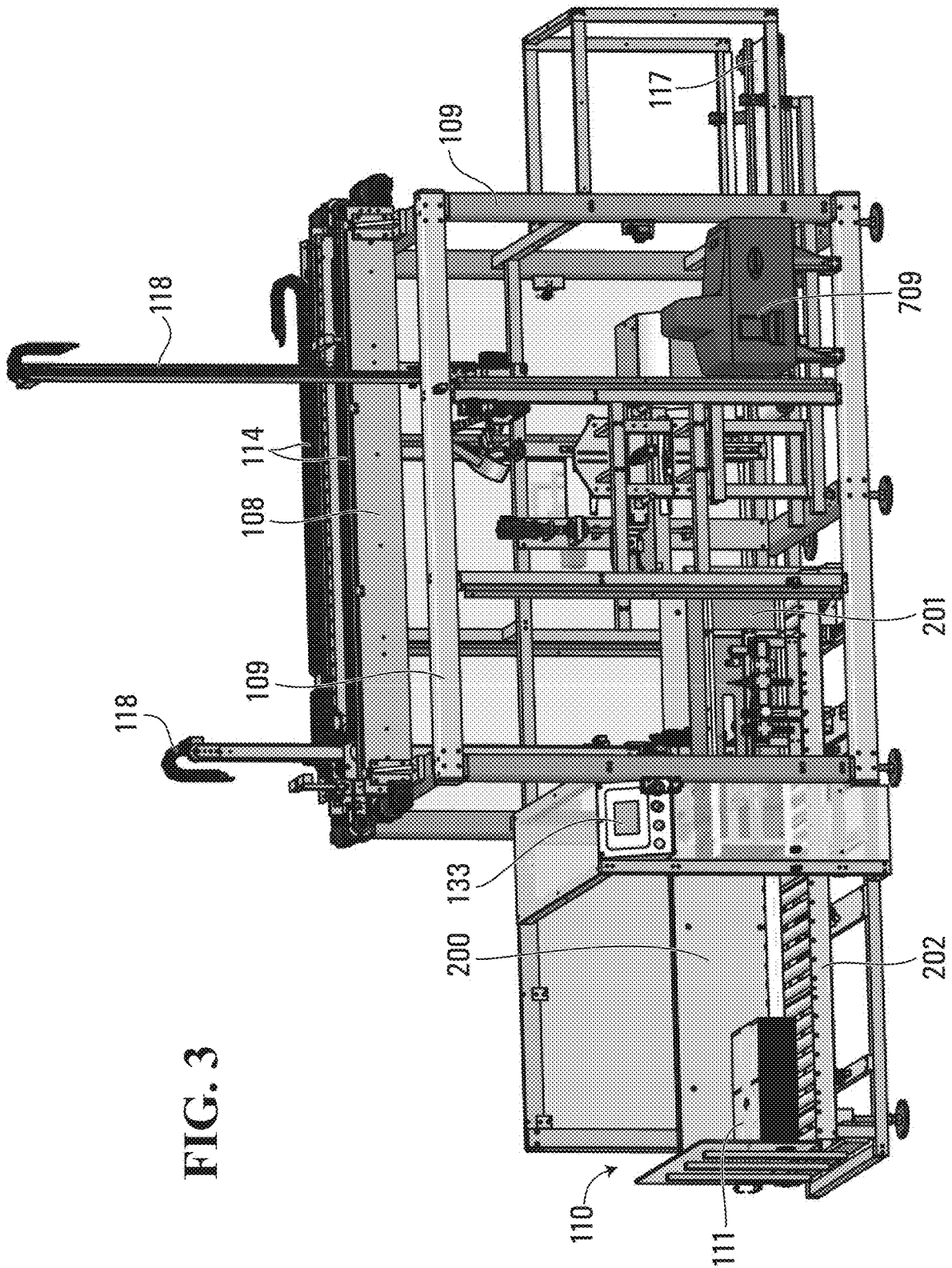
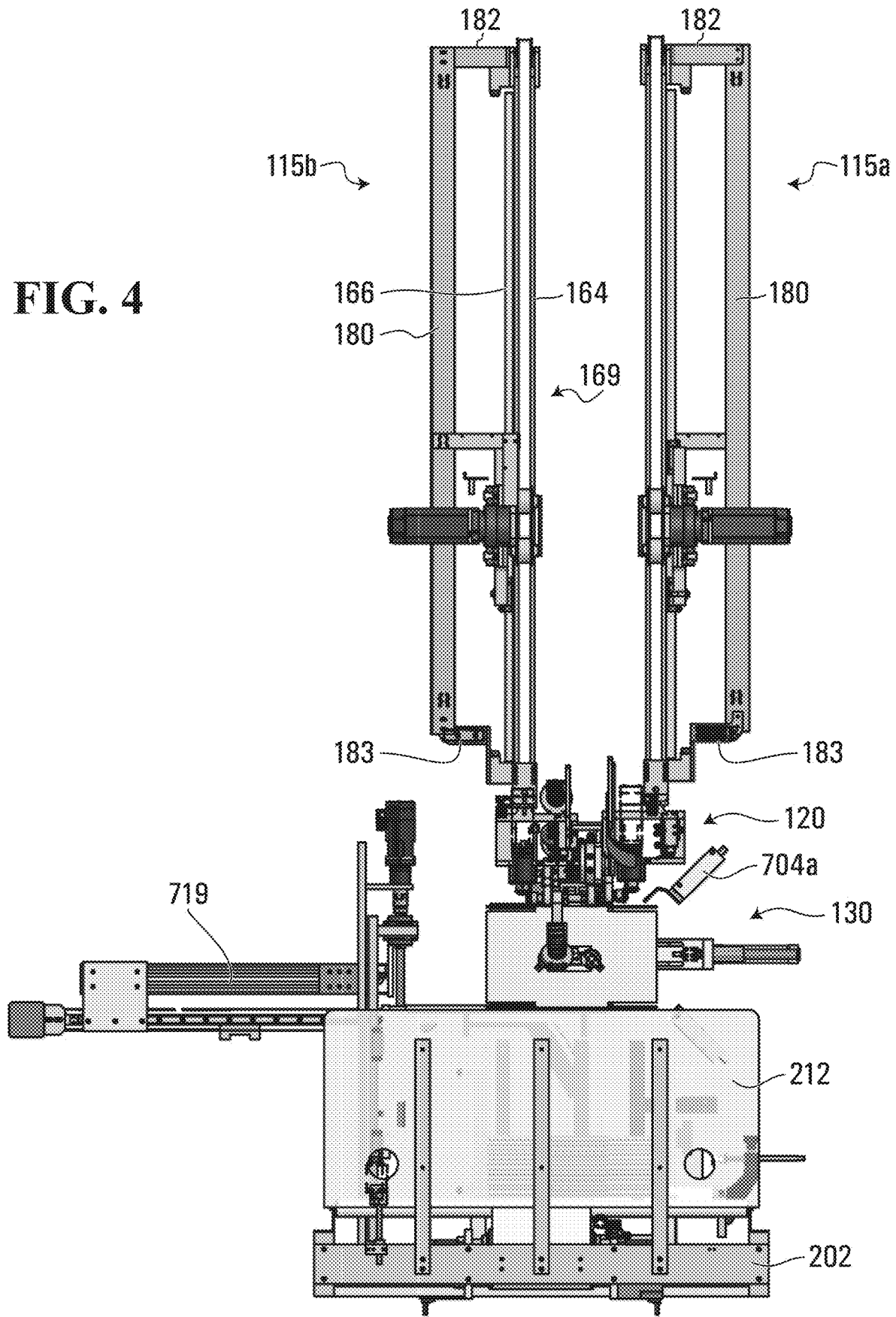

FIG. 3

FIG. 4



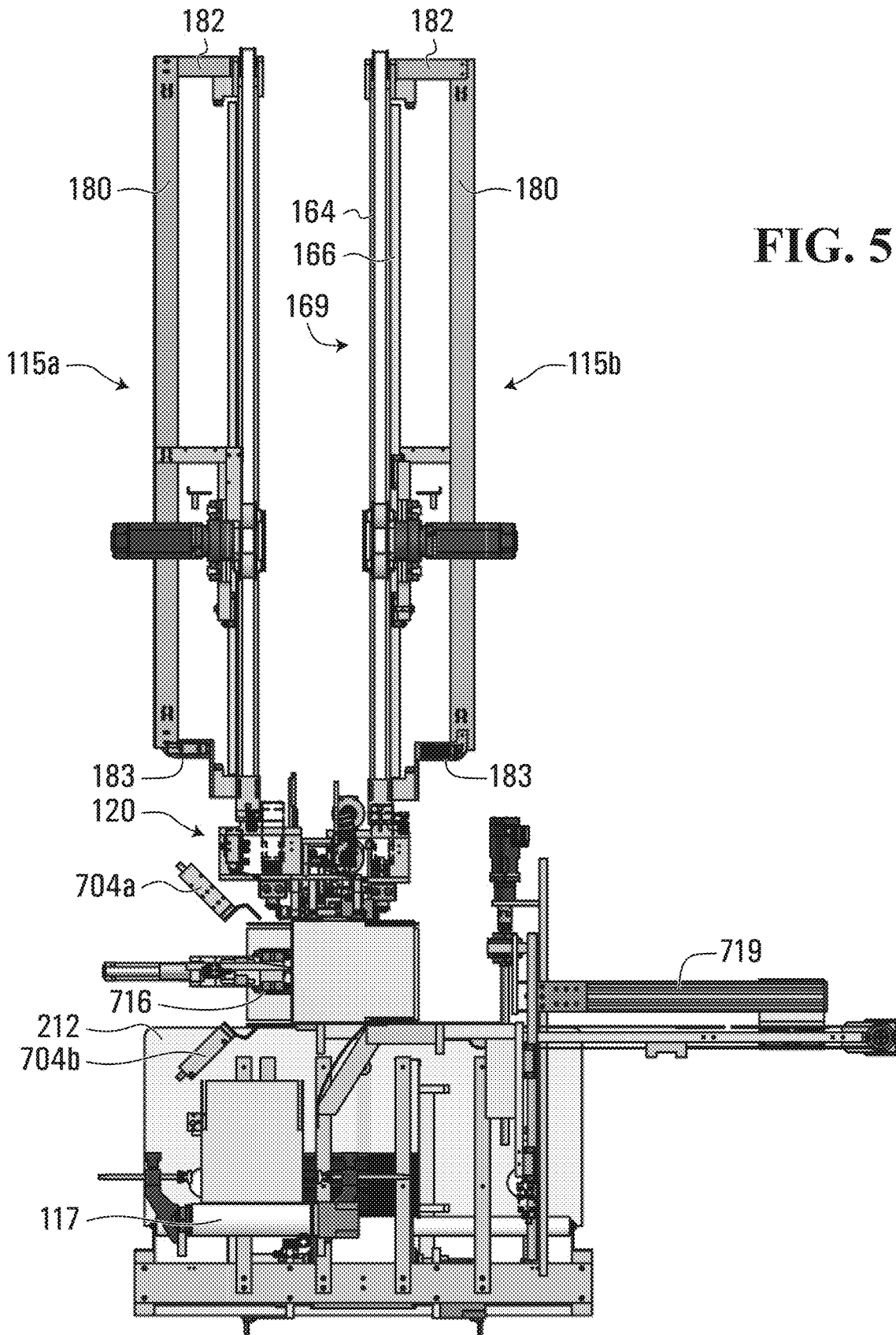

FIG. 5

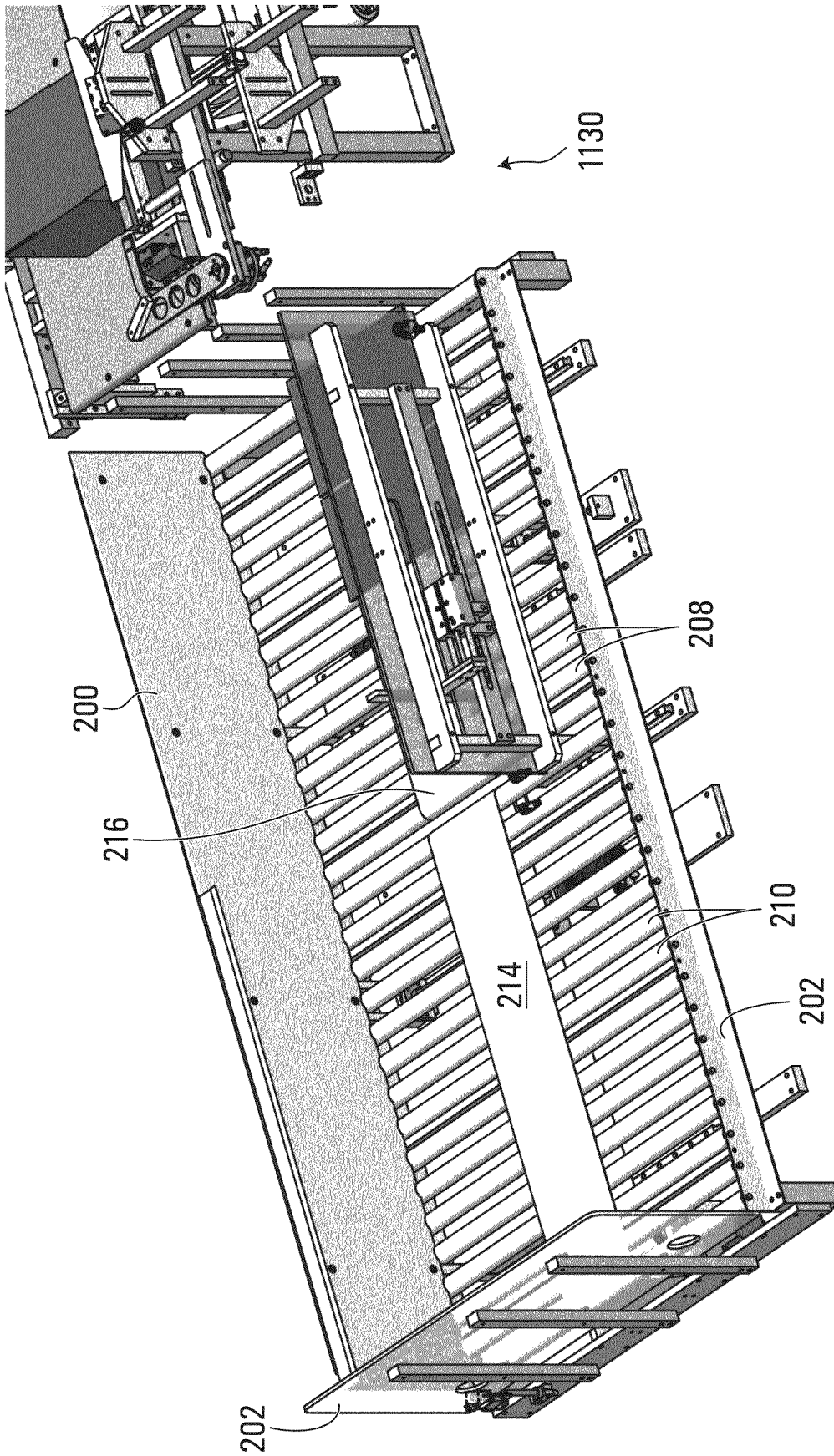

FIG. 6A

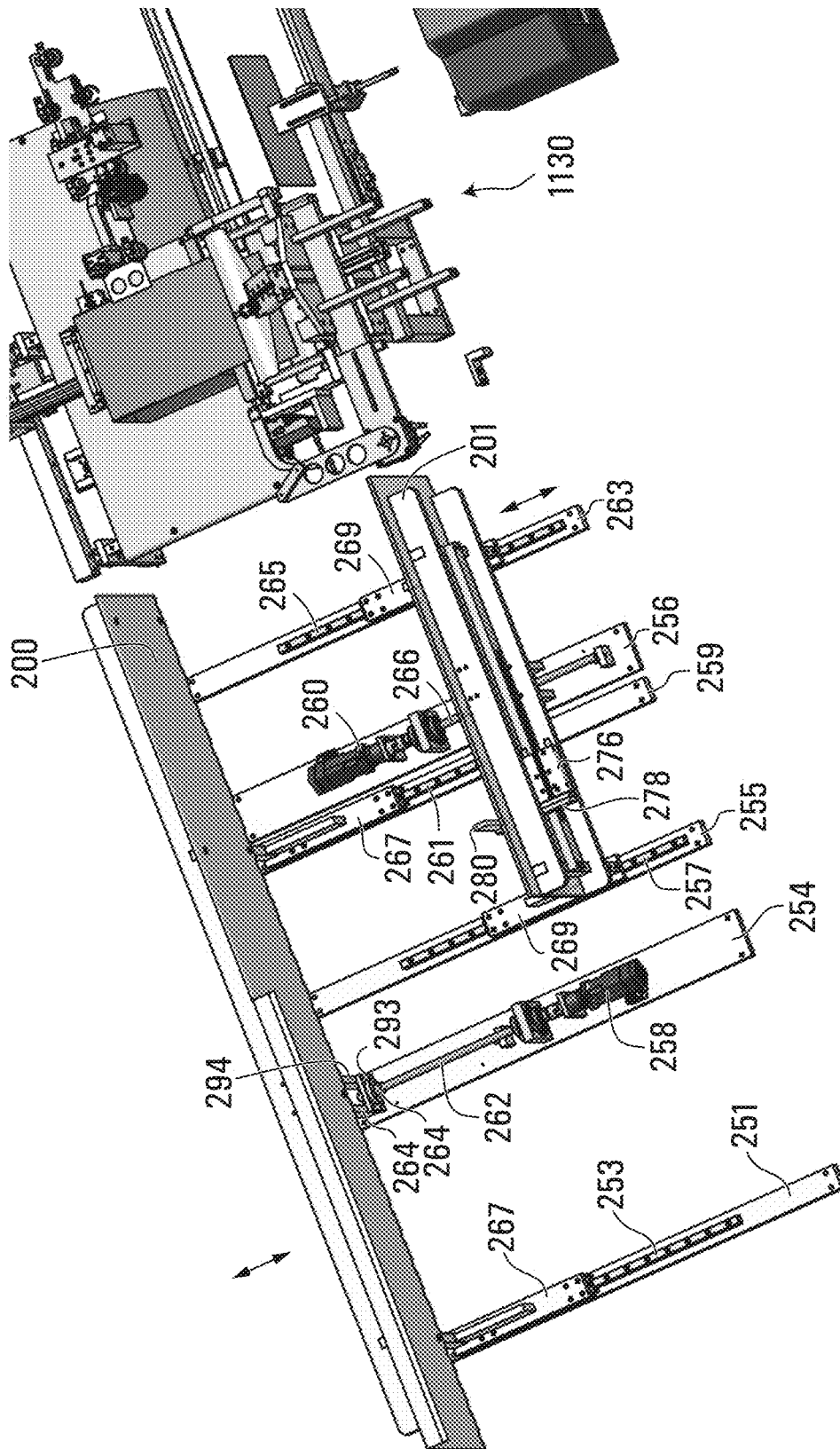

FIG. 6B

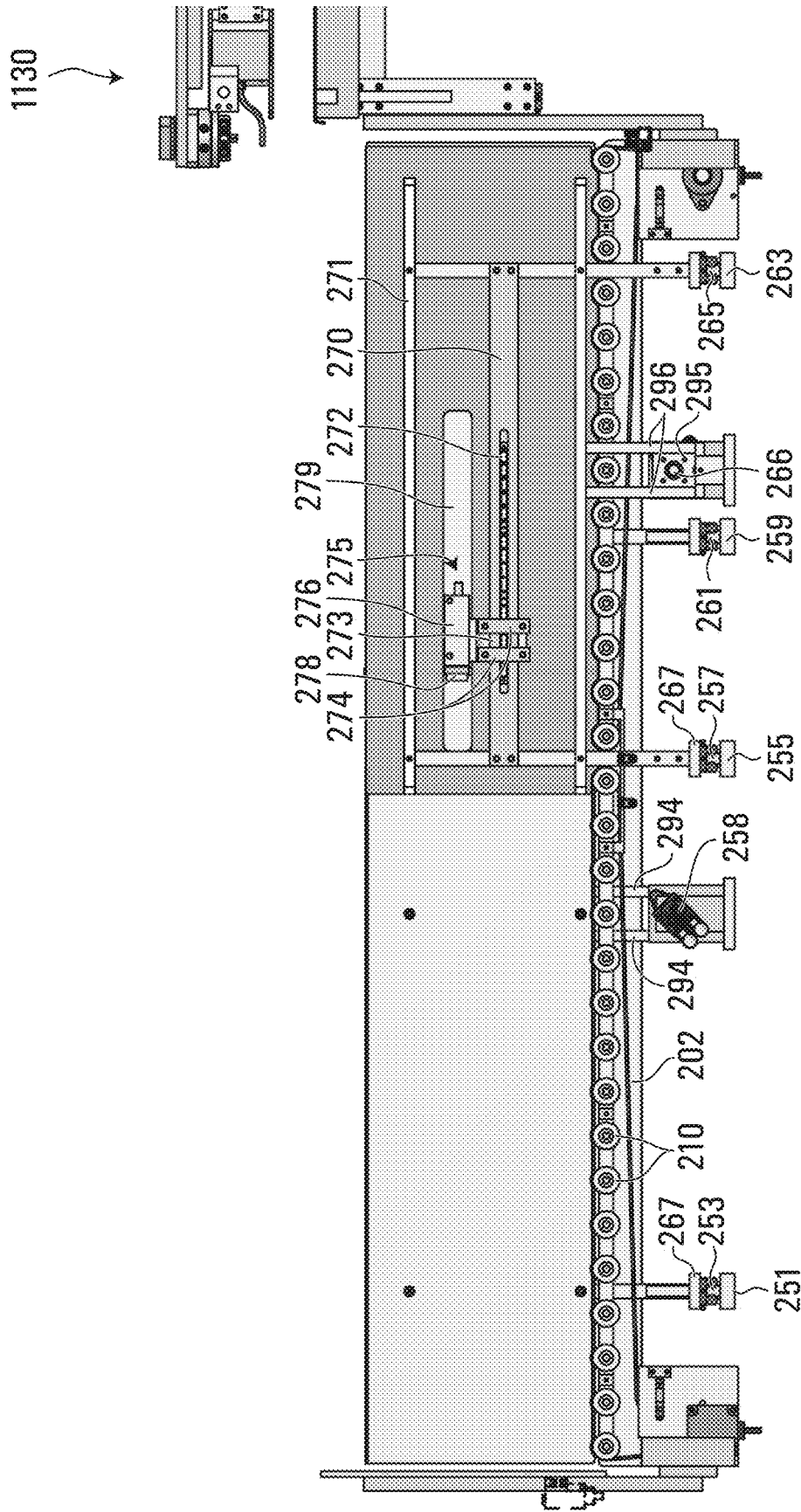

FIG. 6C

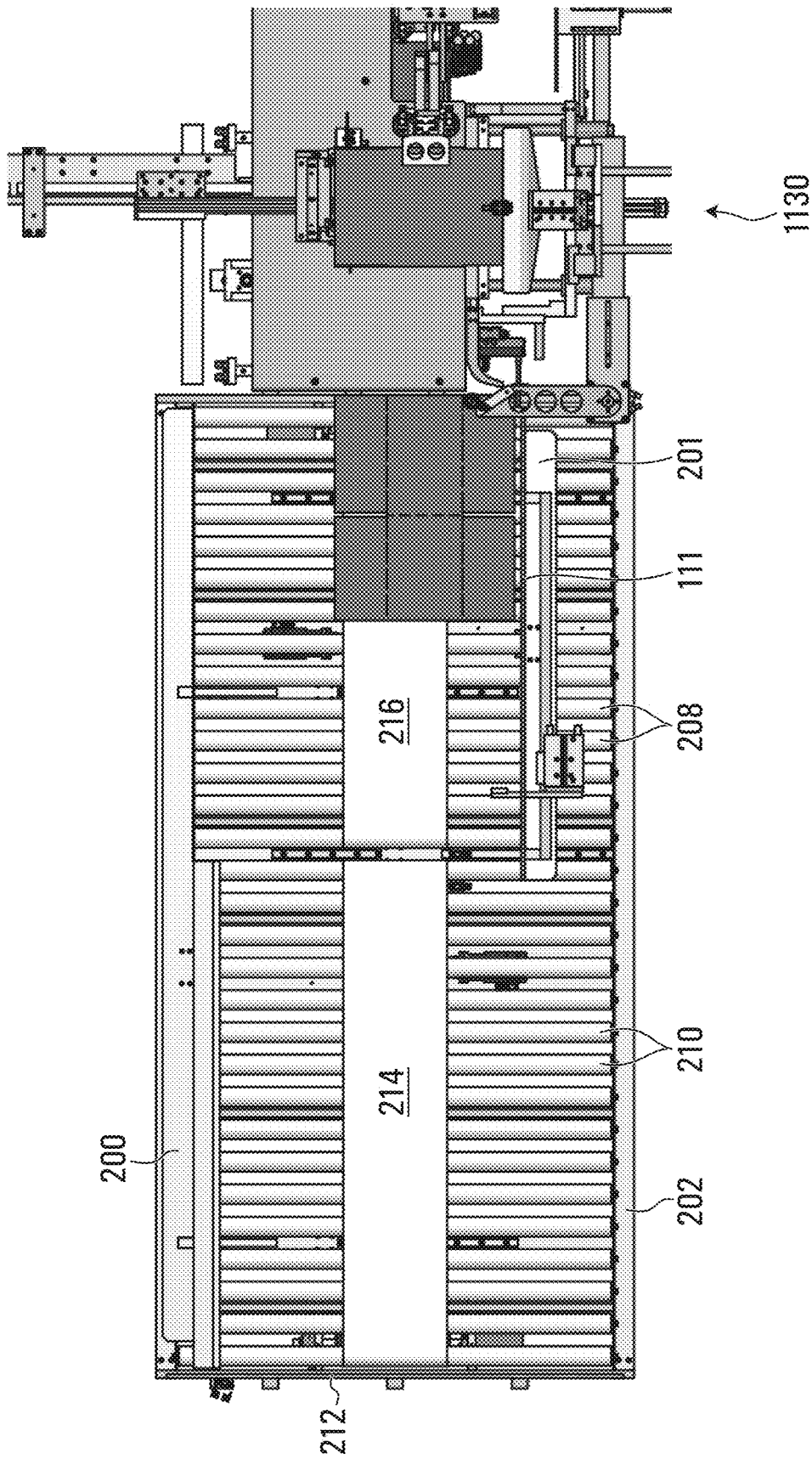
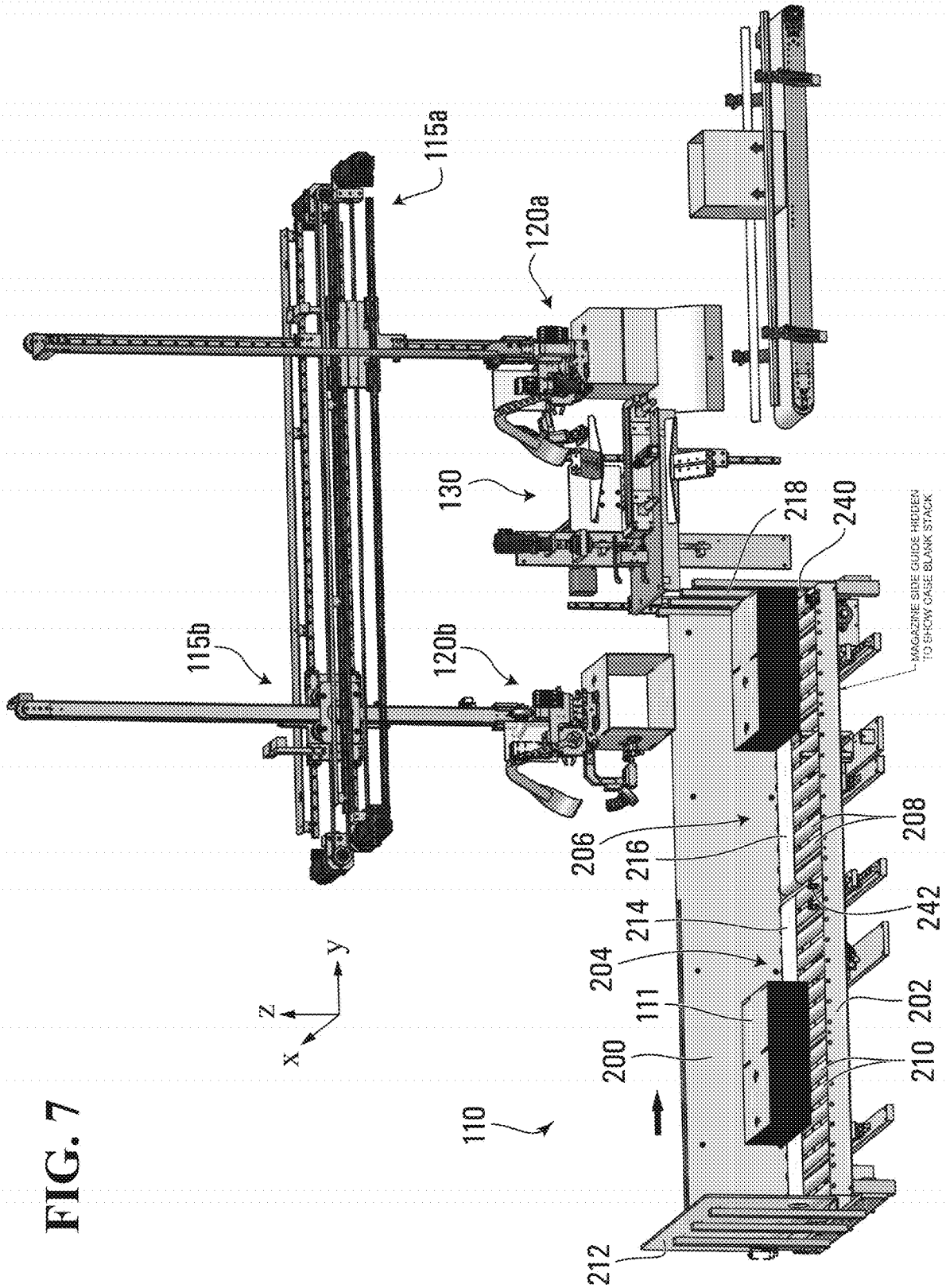

FIG. 6D

FIG. 7



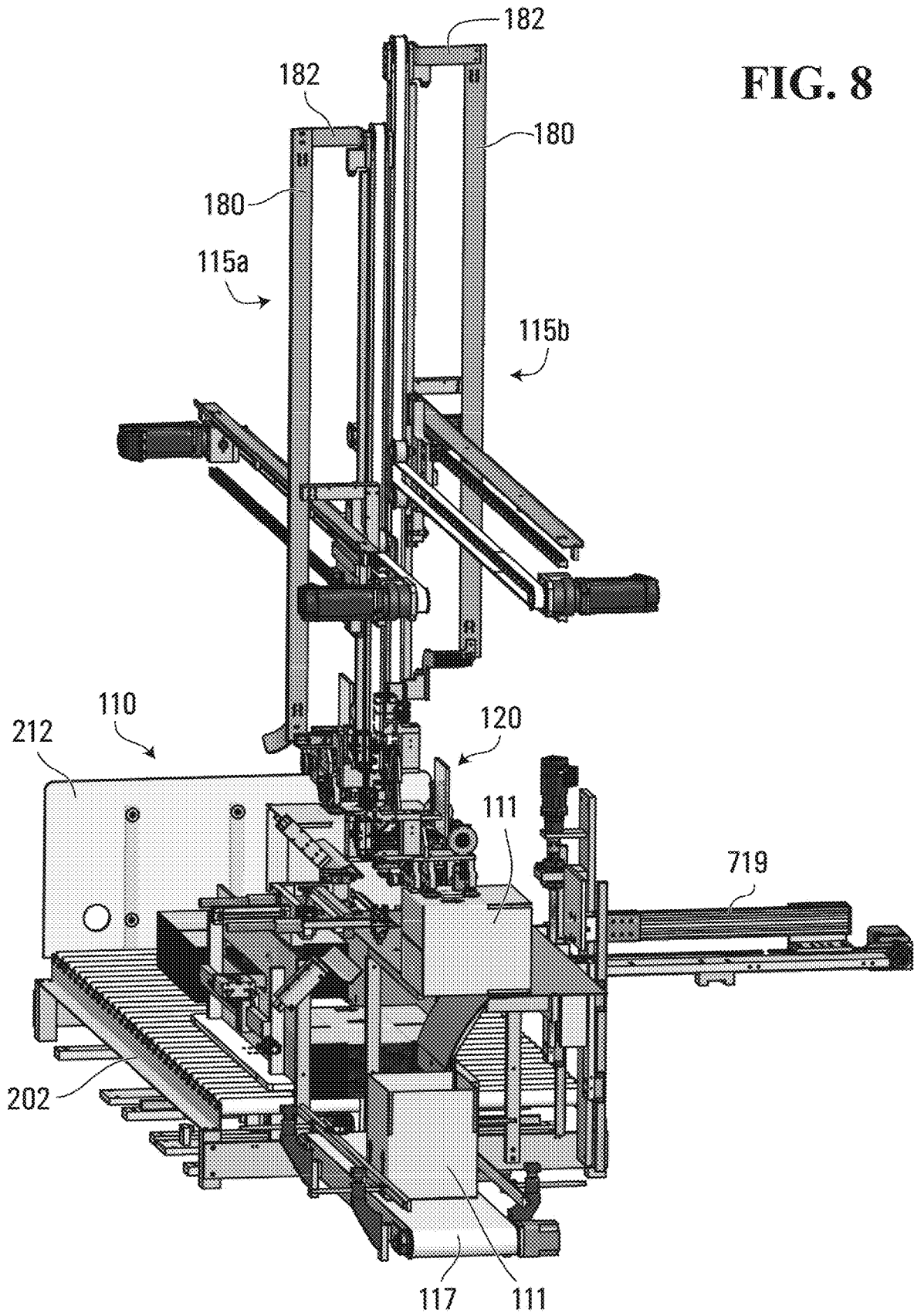
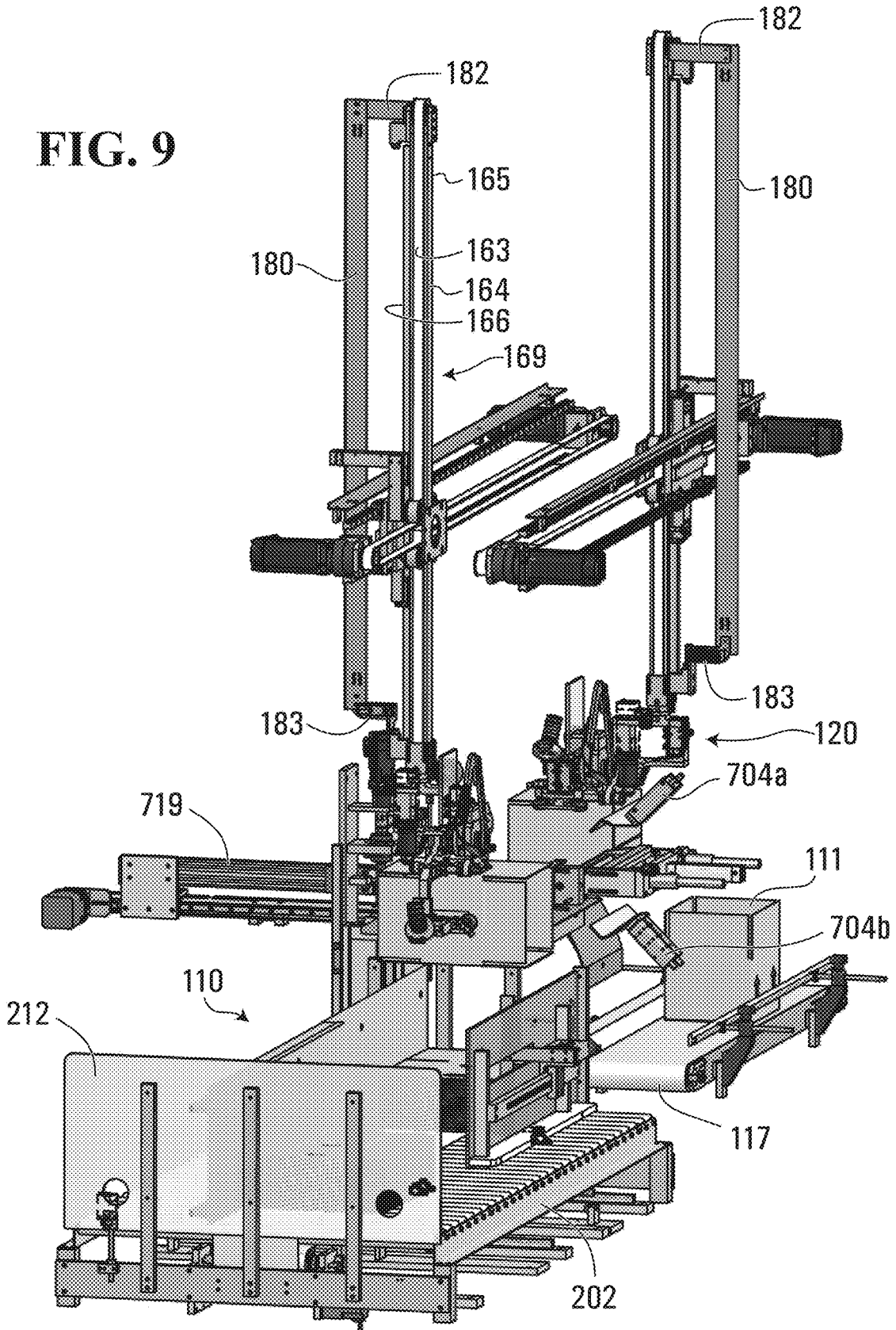

FIG. 8

FIG. 9



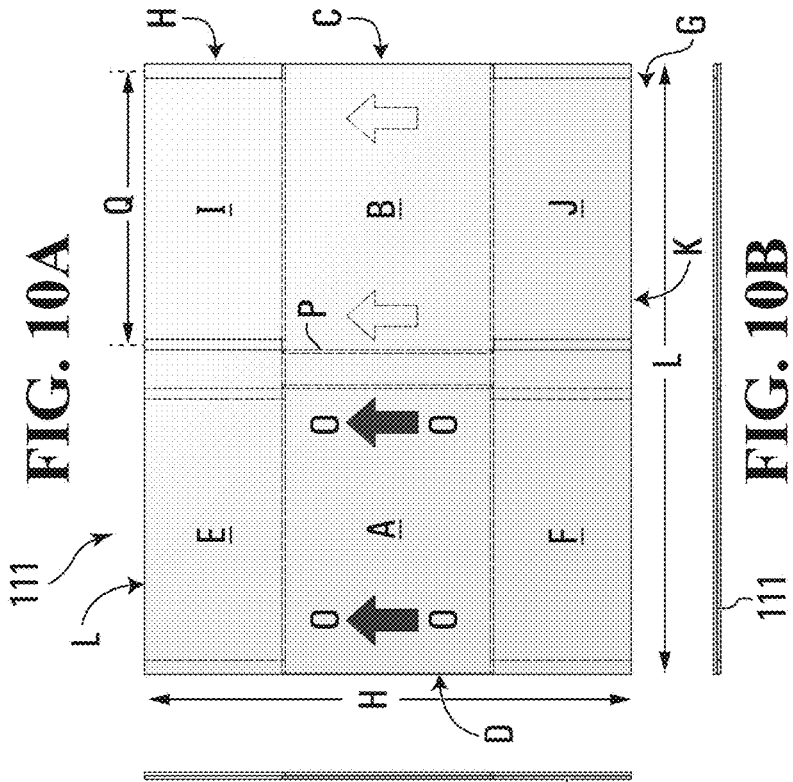

FIG. 10A

FIG. 10B



FIG. 10C

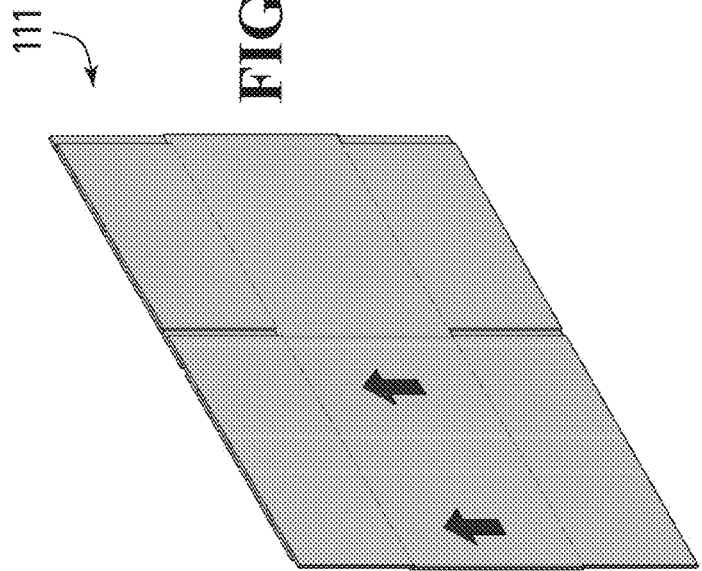

FIG. 10E

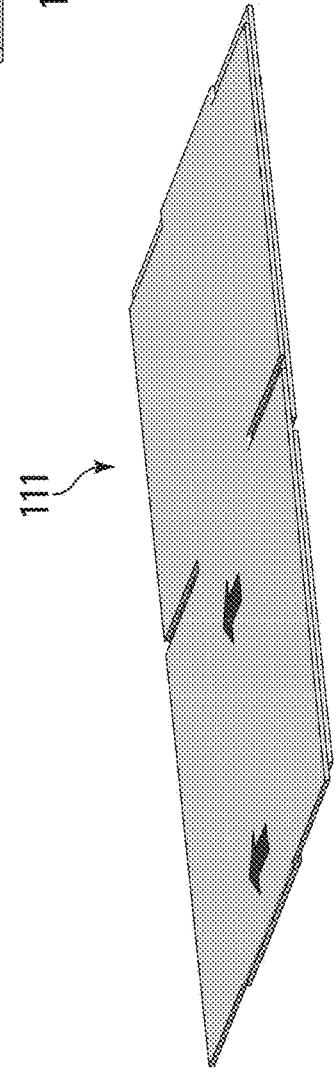

FIG. 10D

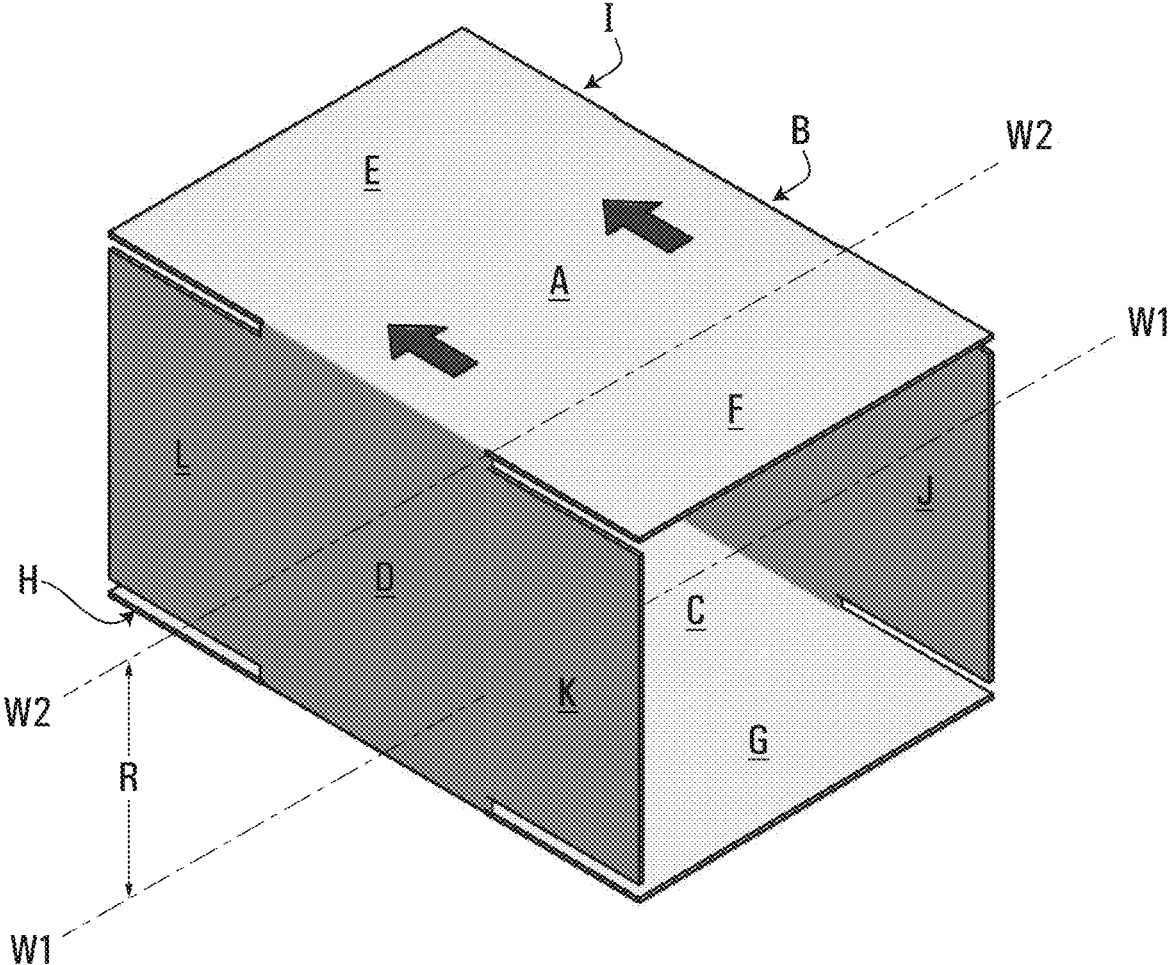

FIG. 11

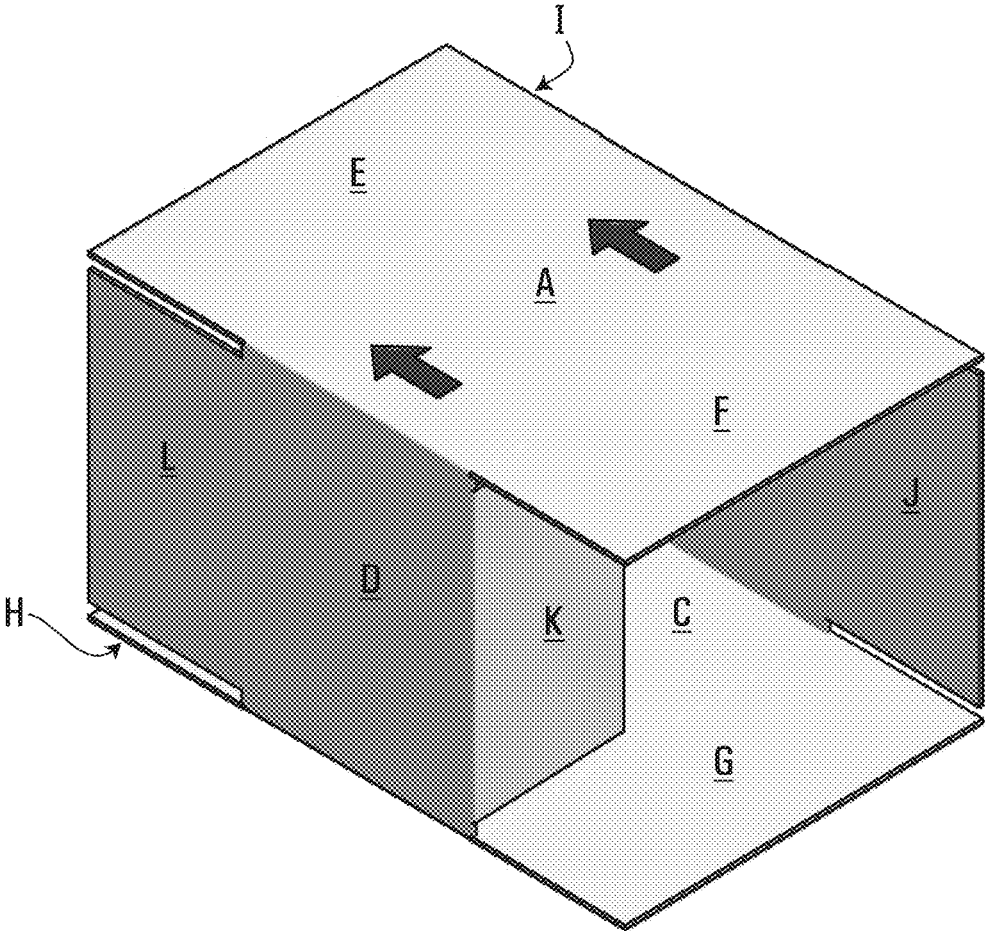

FIG. 12

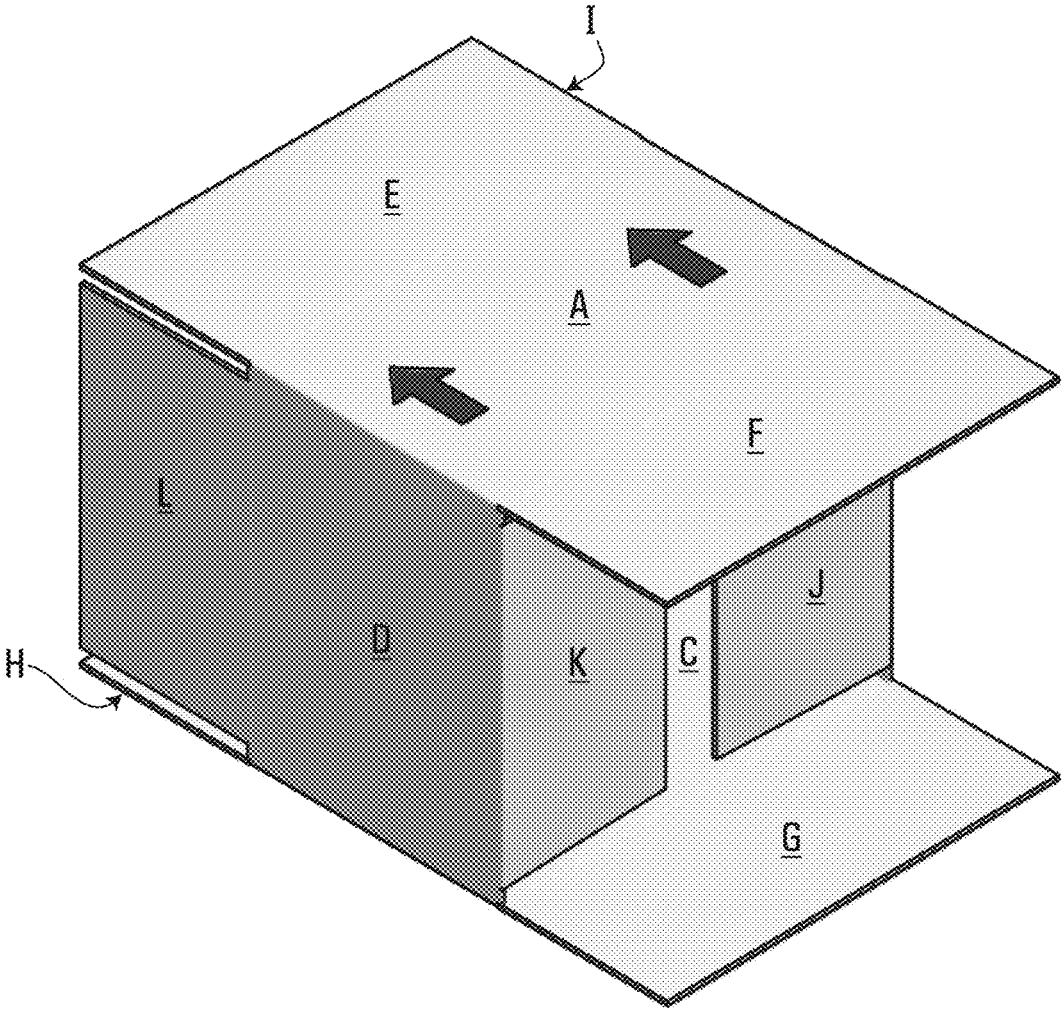

FIG. 13

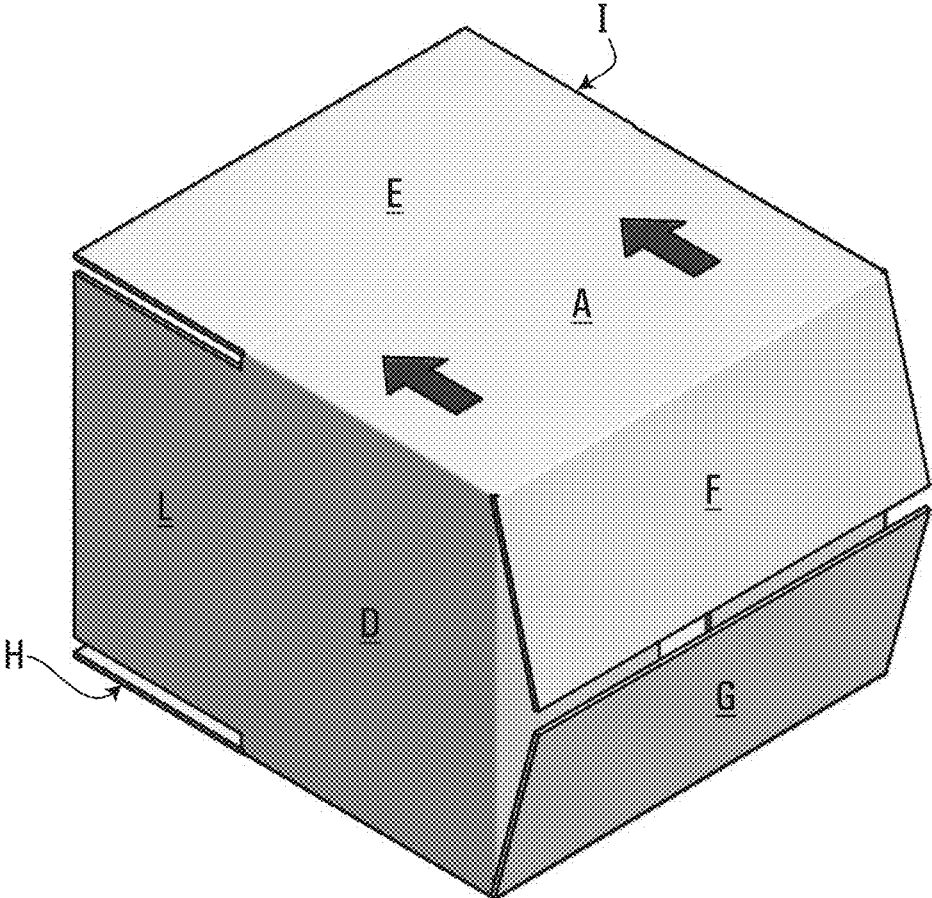

FIG. 14

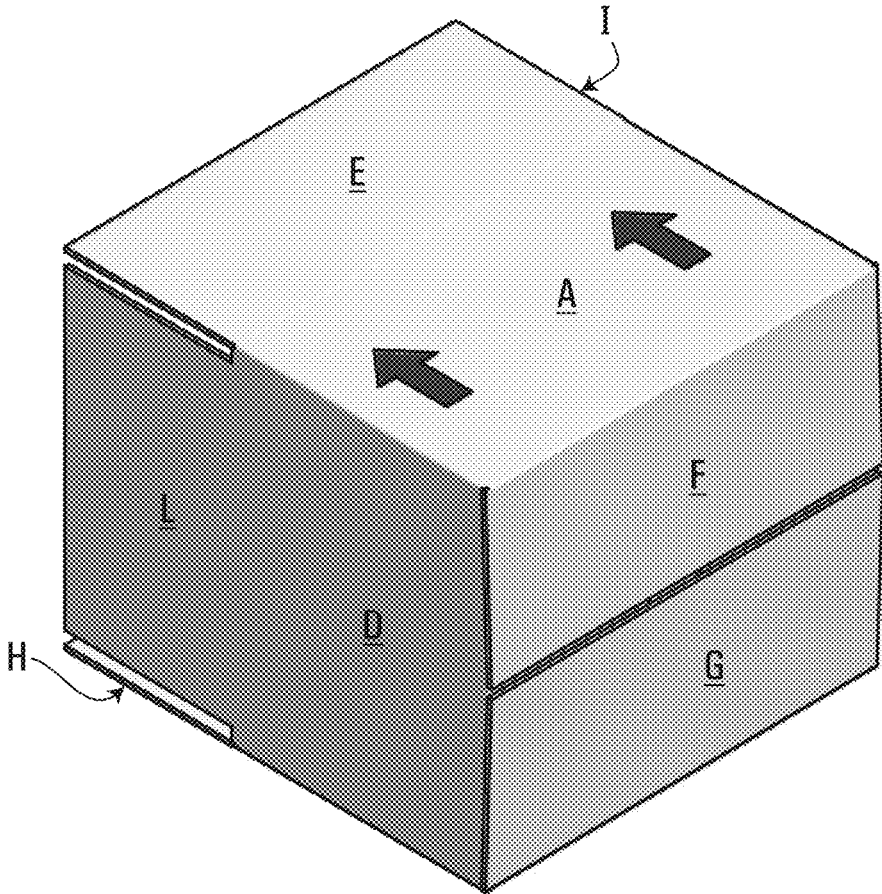

FIG. 15

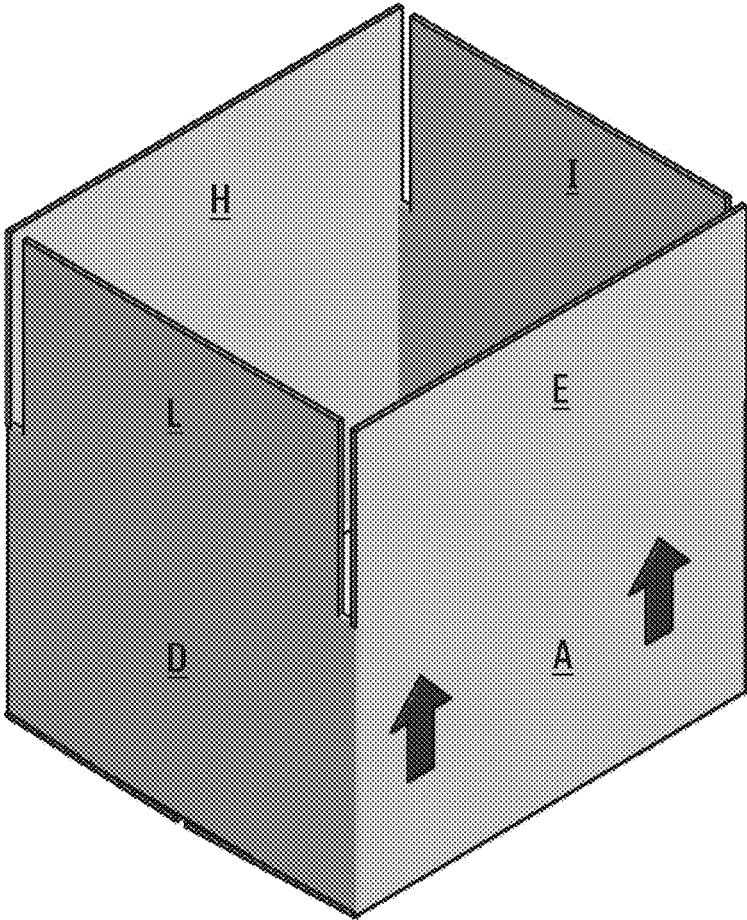

FIG. 16

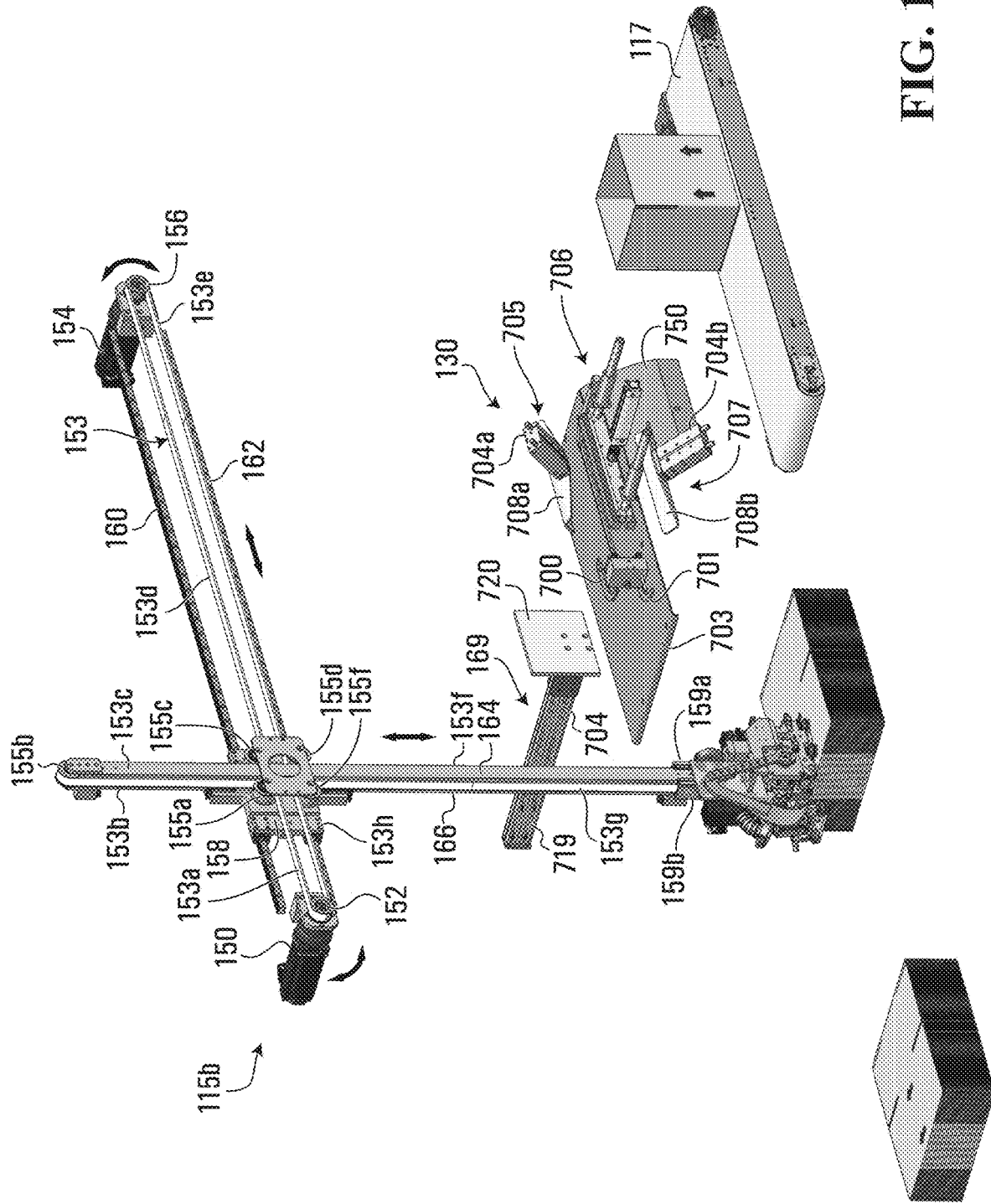

FIG. 17

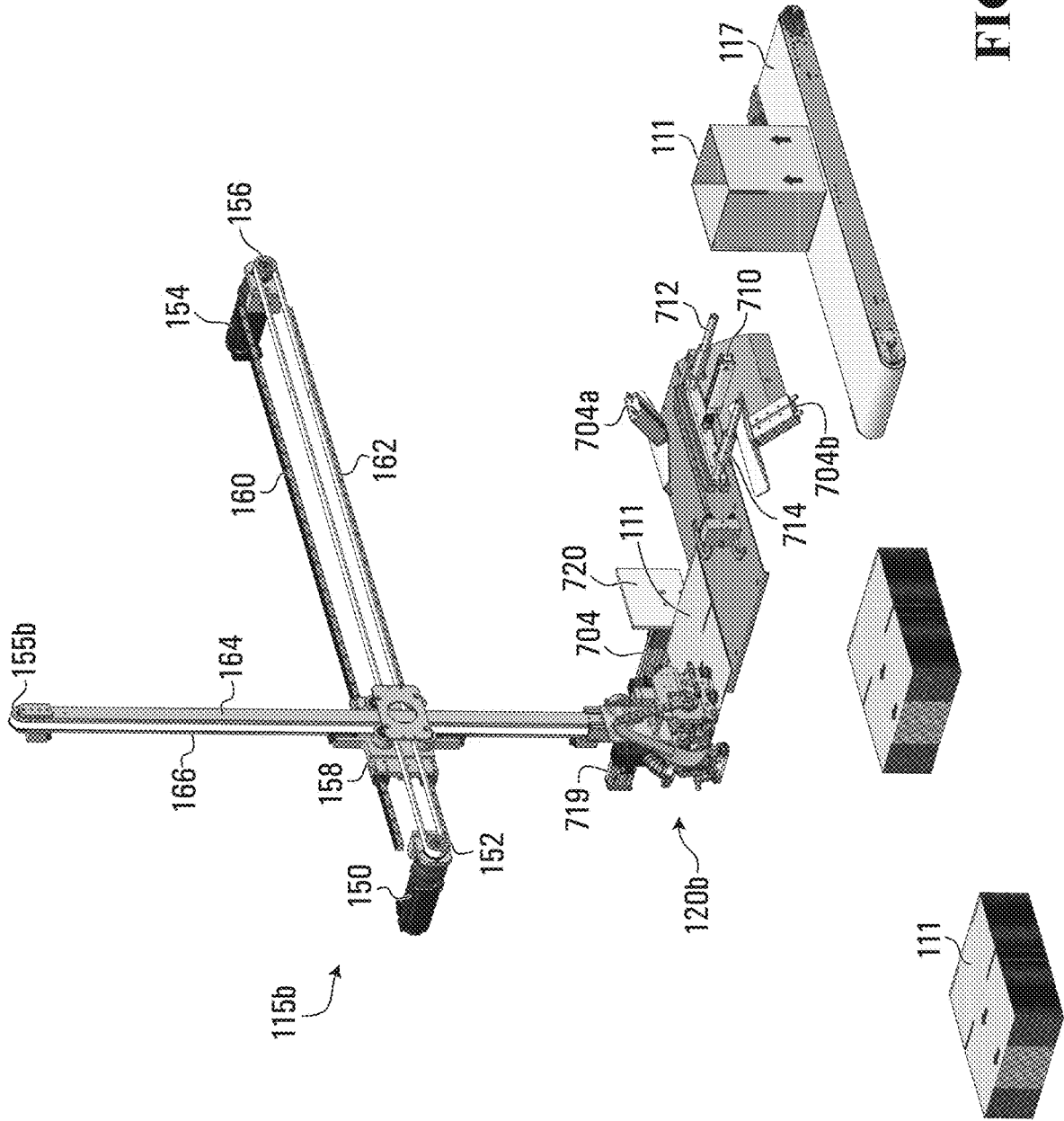

FIG. 18

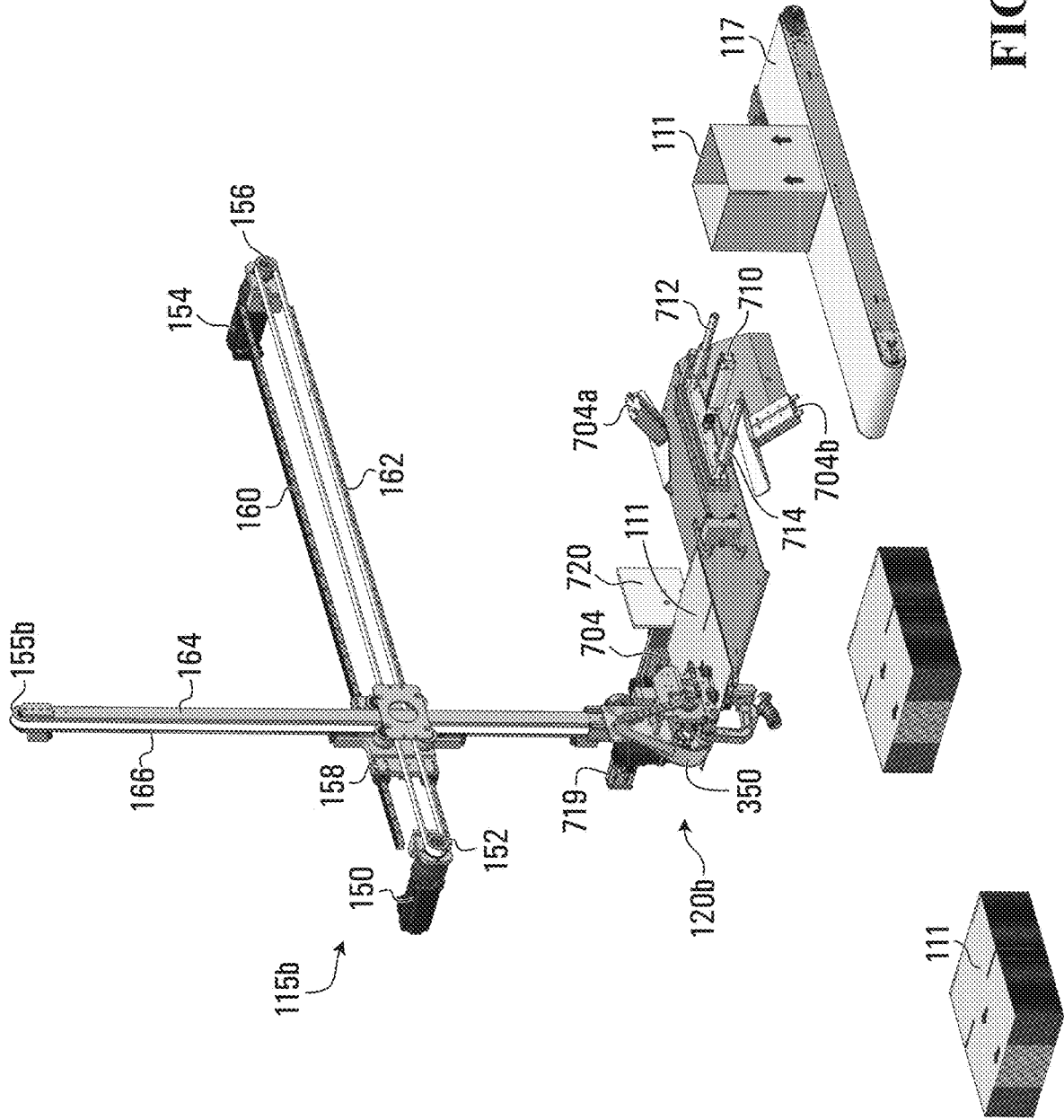

FIG. 19

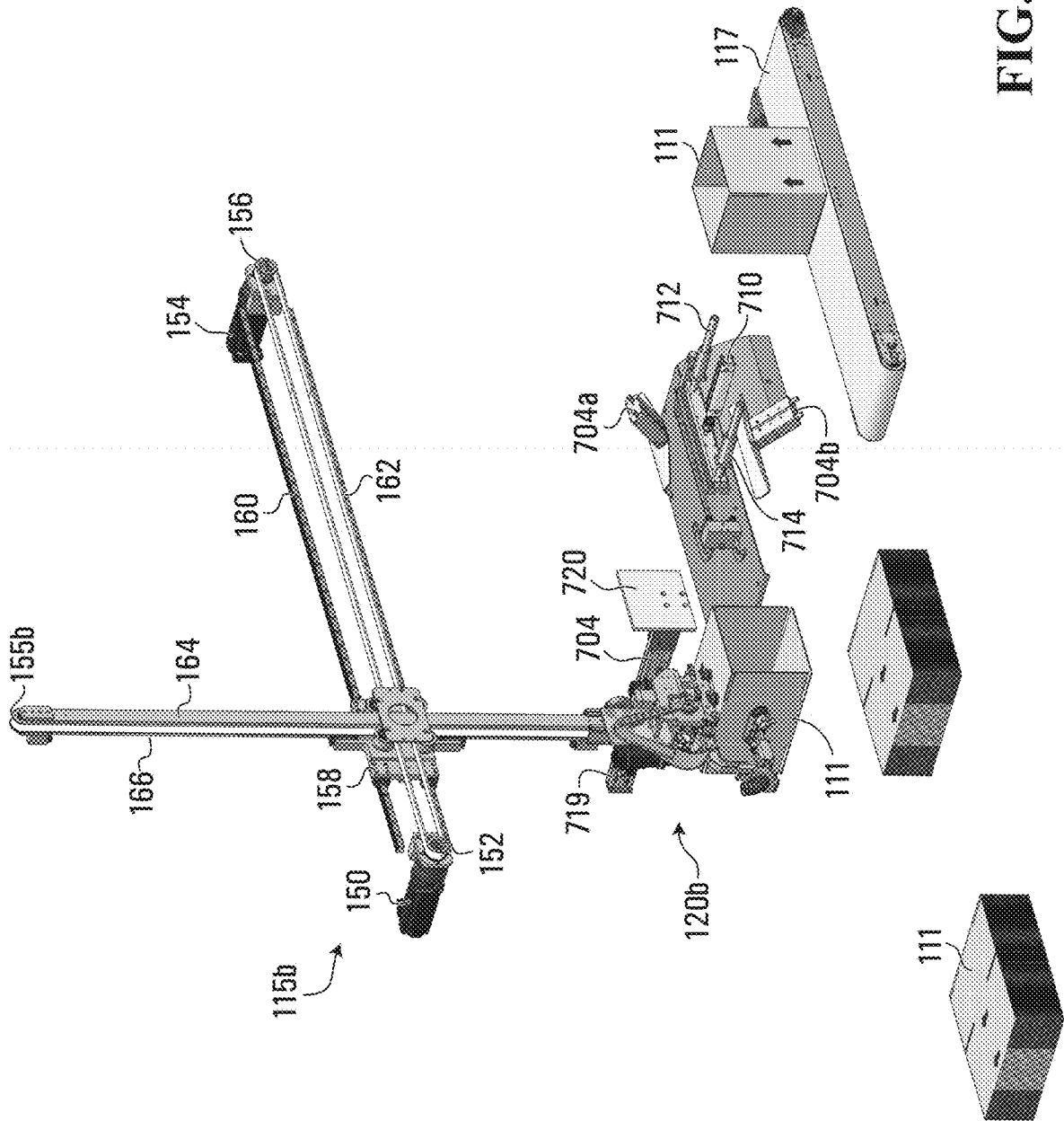

FIG. 20

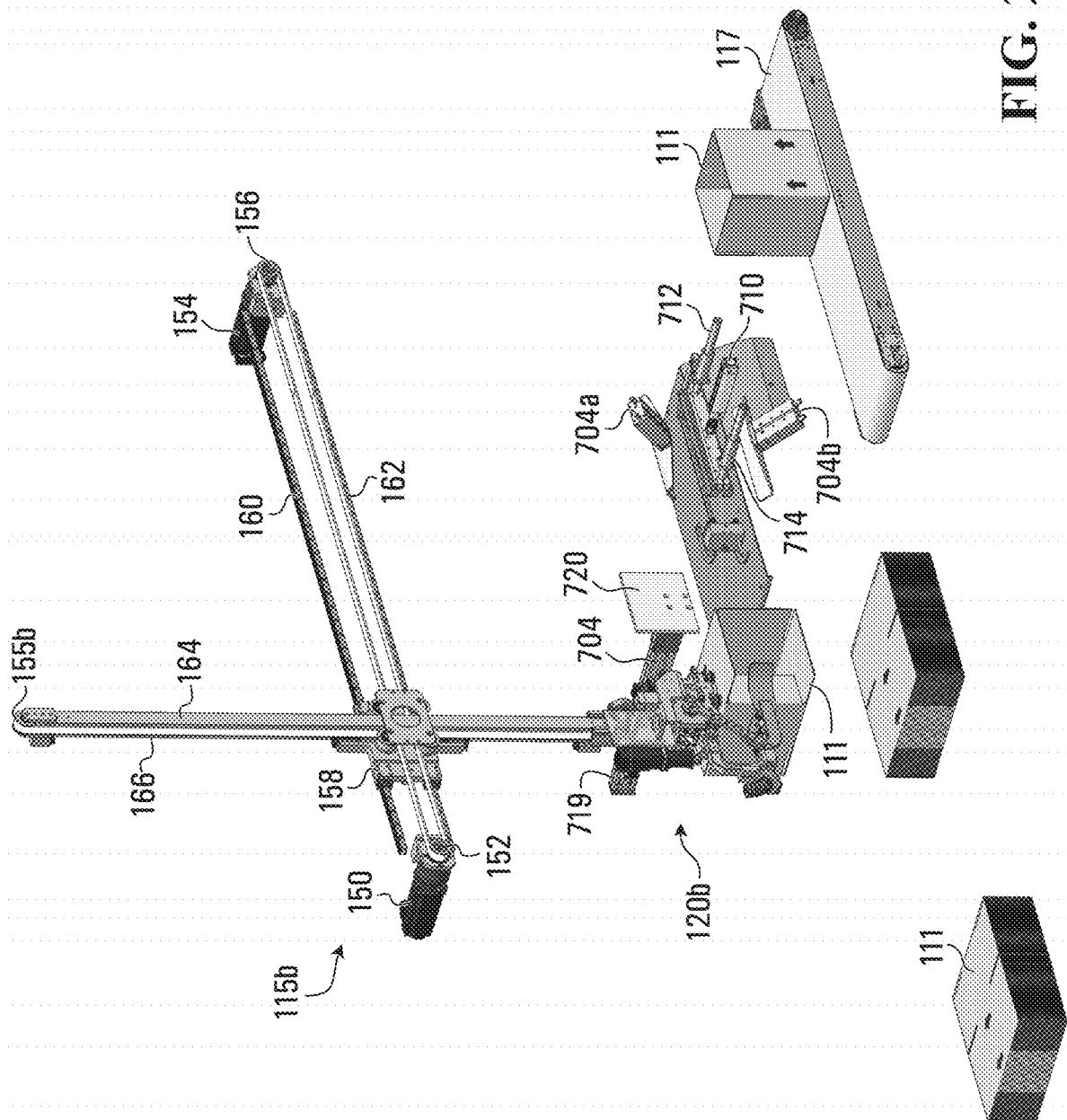

FIG. 21

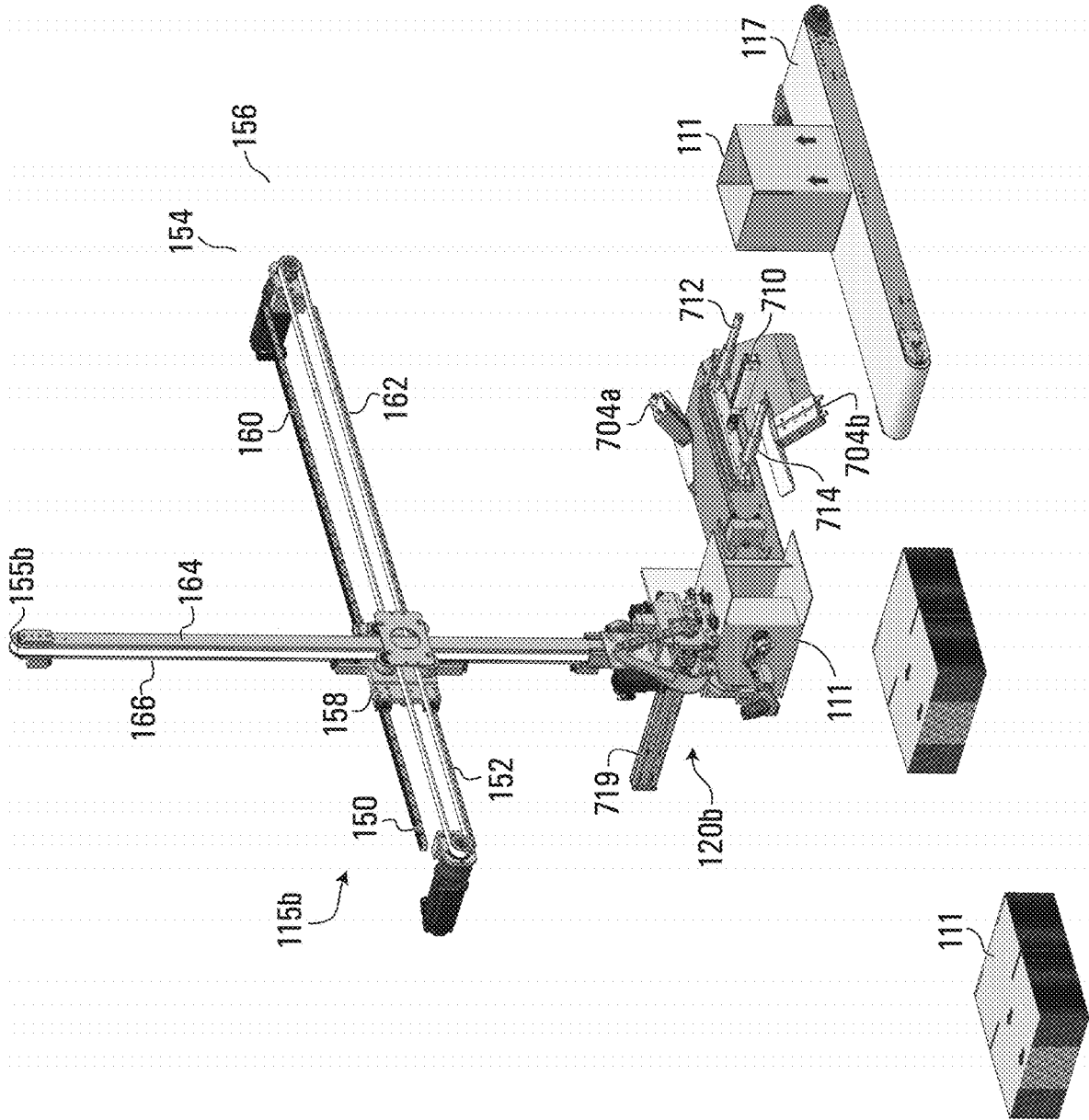

FIG. 22

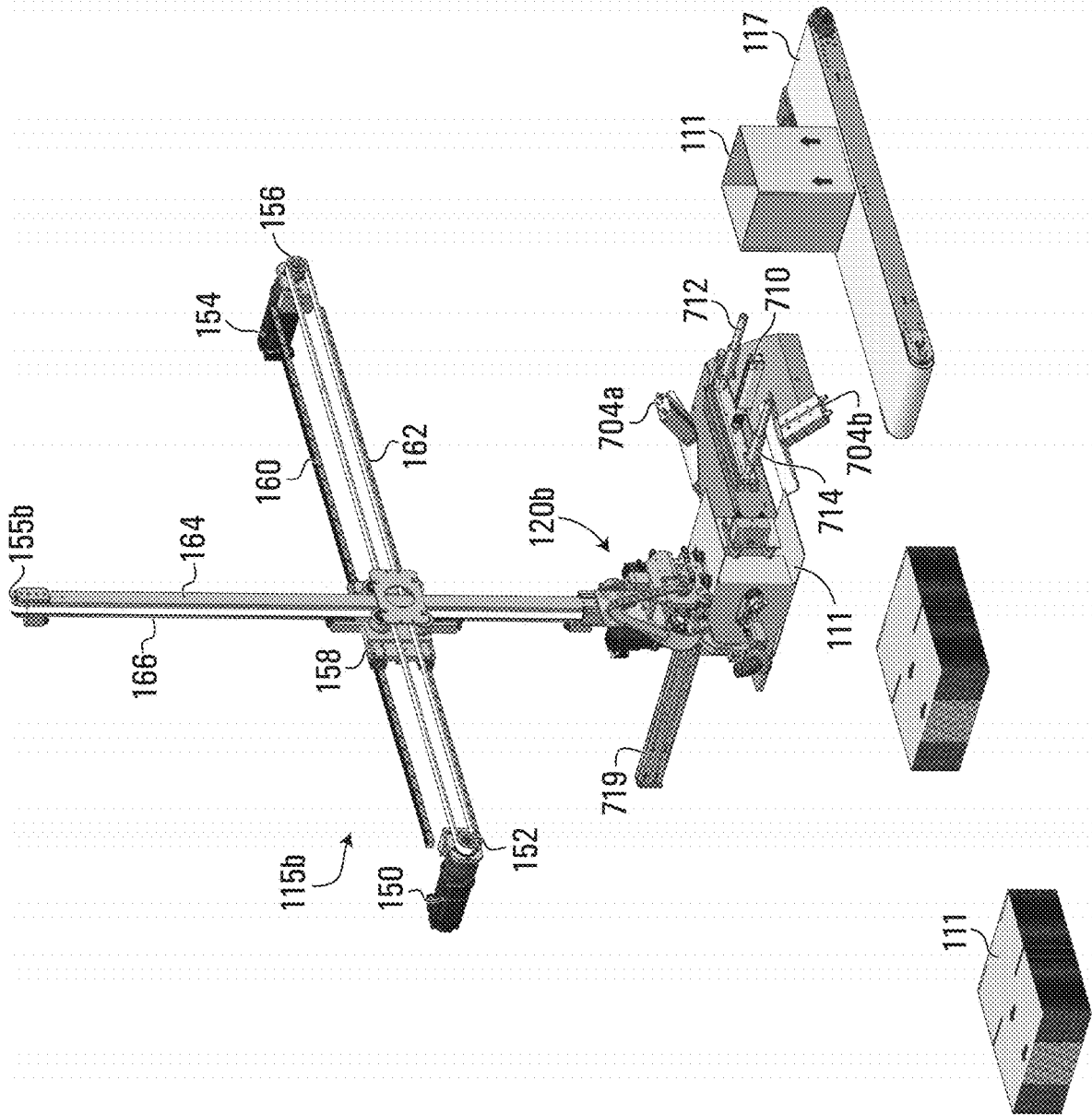

FIG. 23

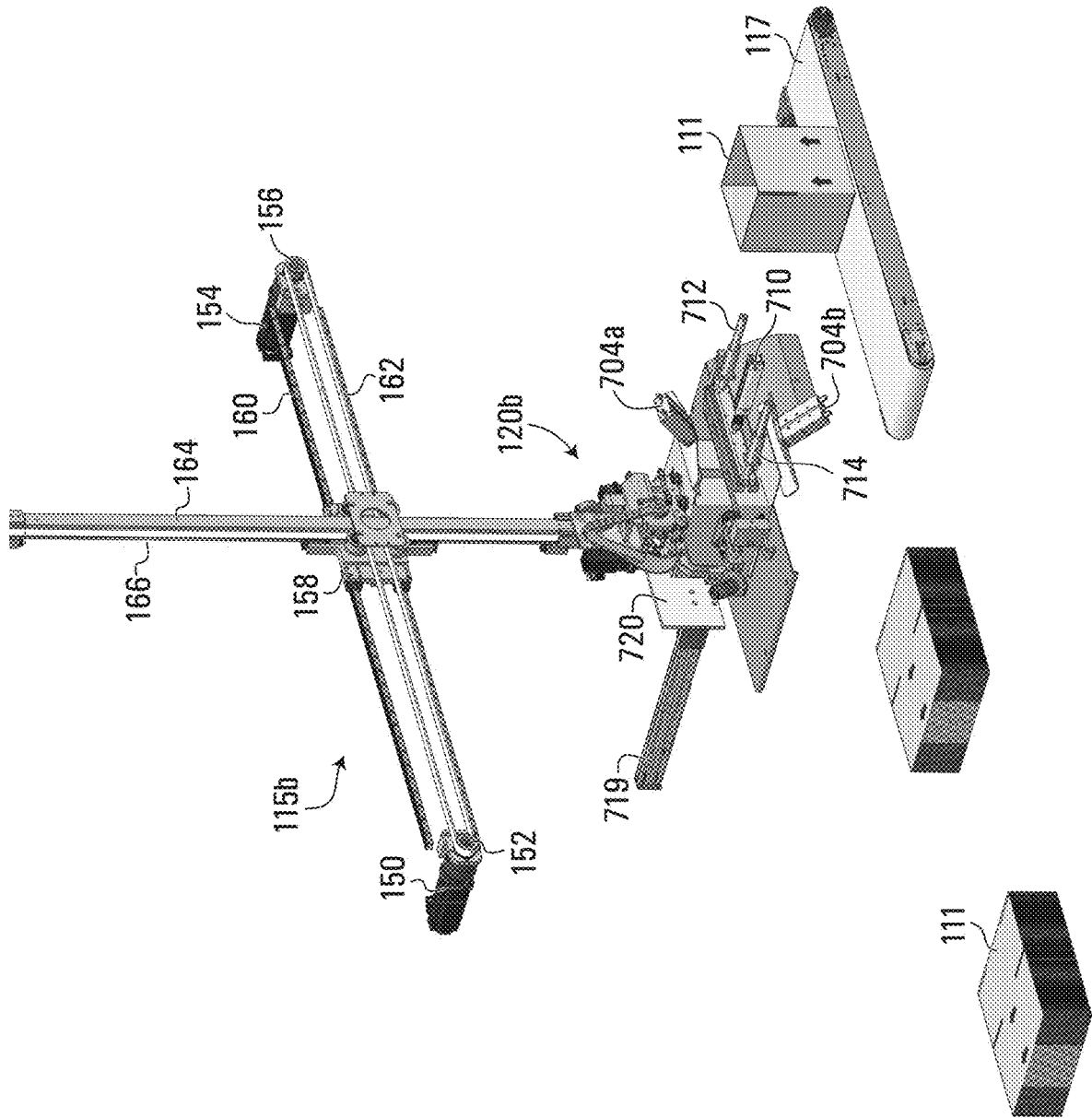

FIG. 24

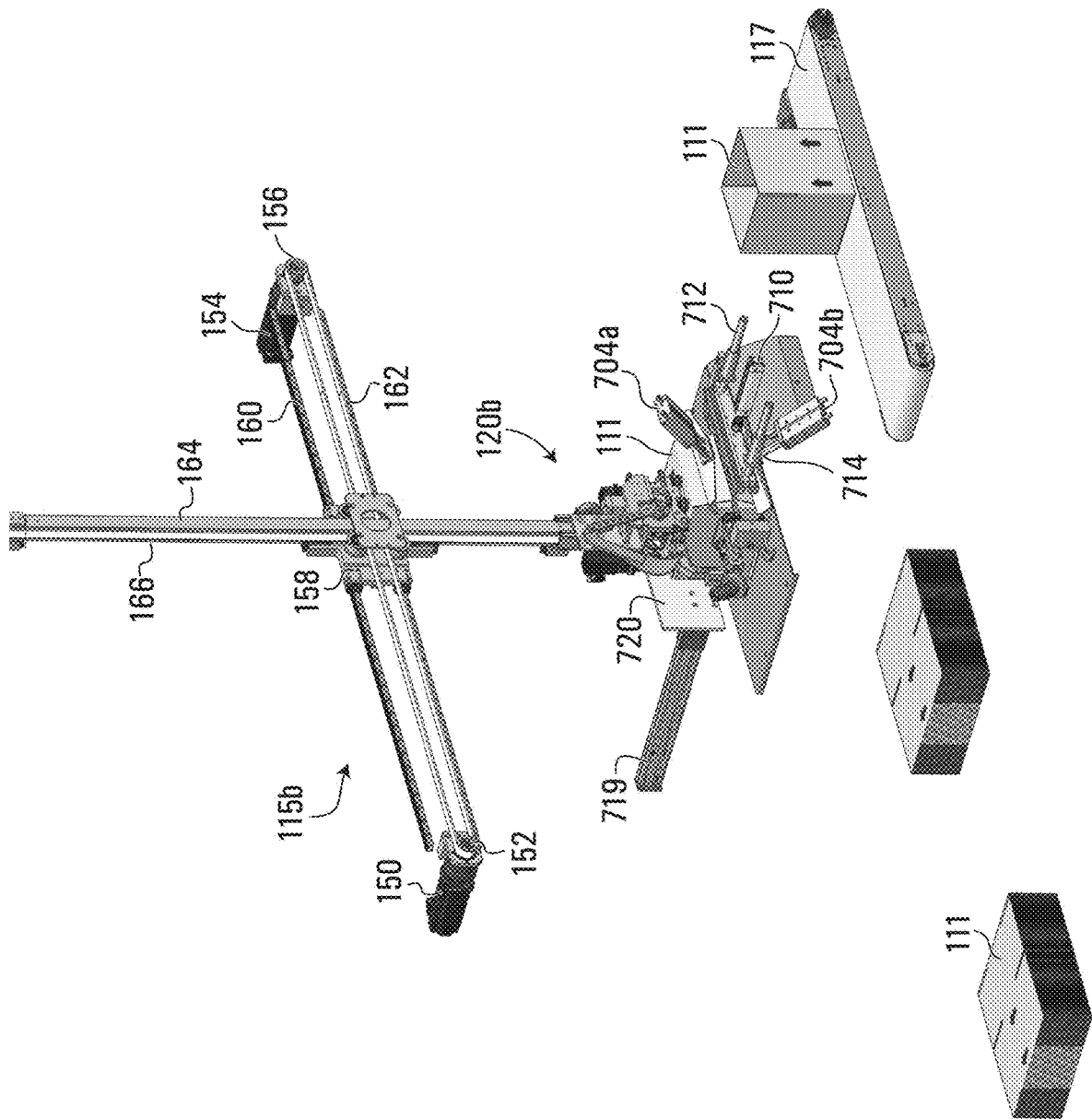

FIG. 25

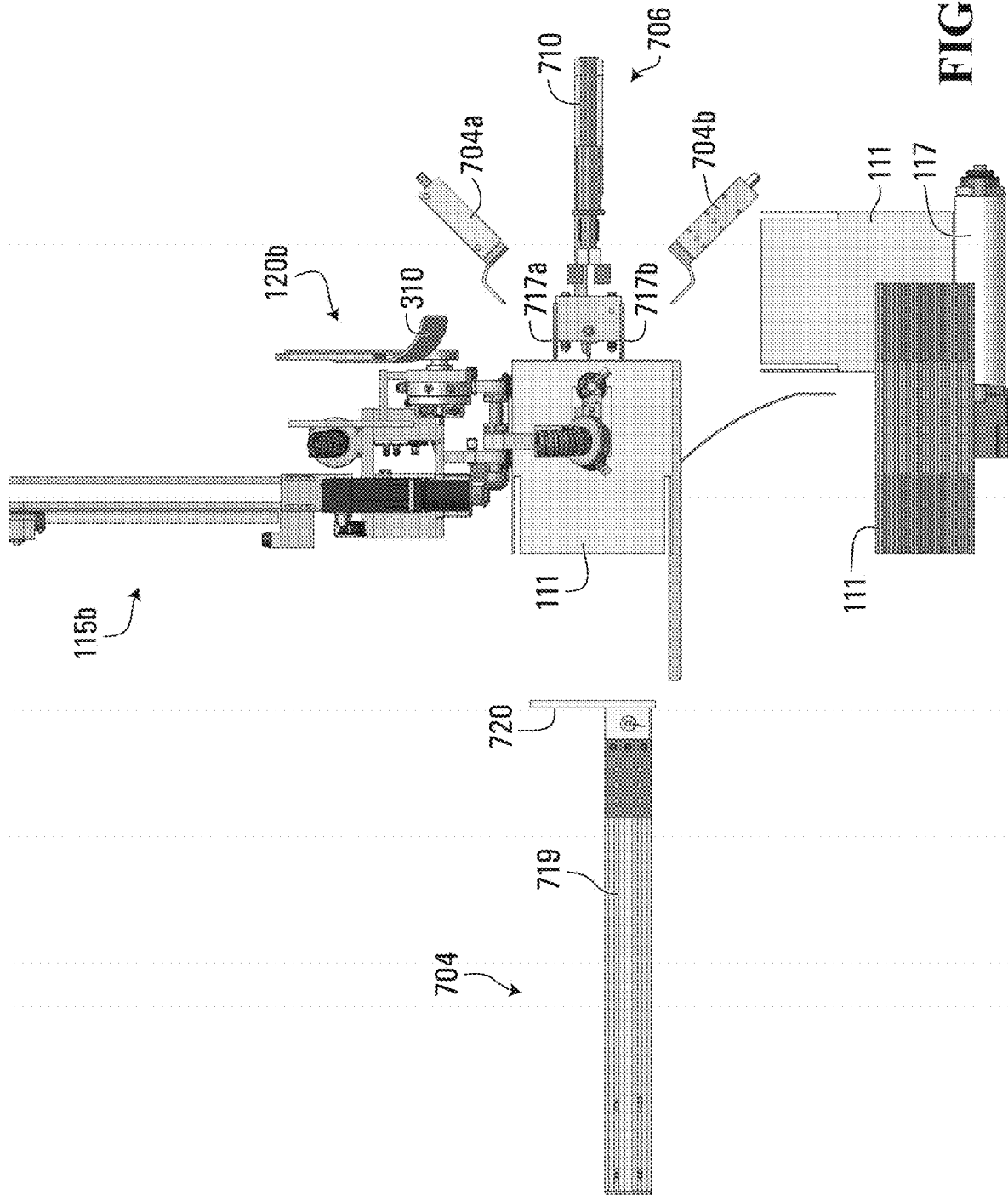

FIG. 26

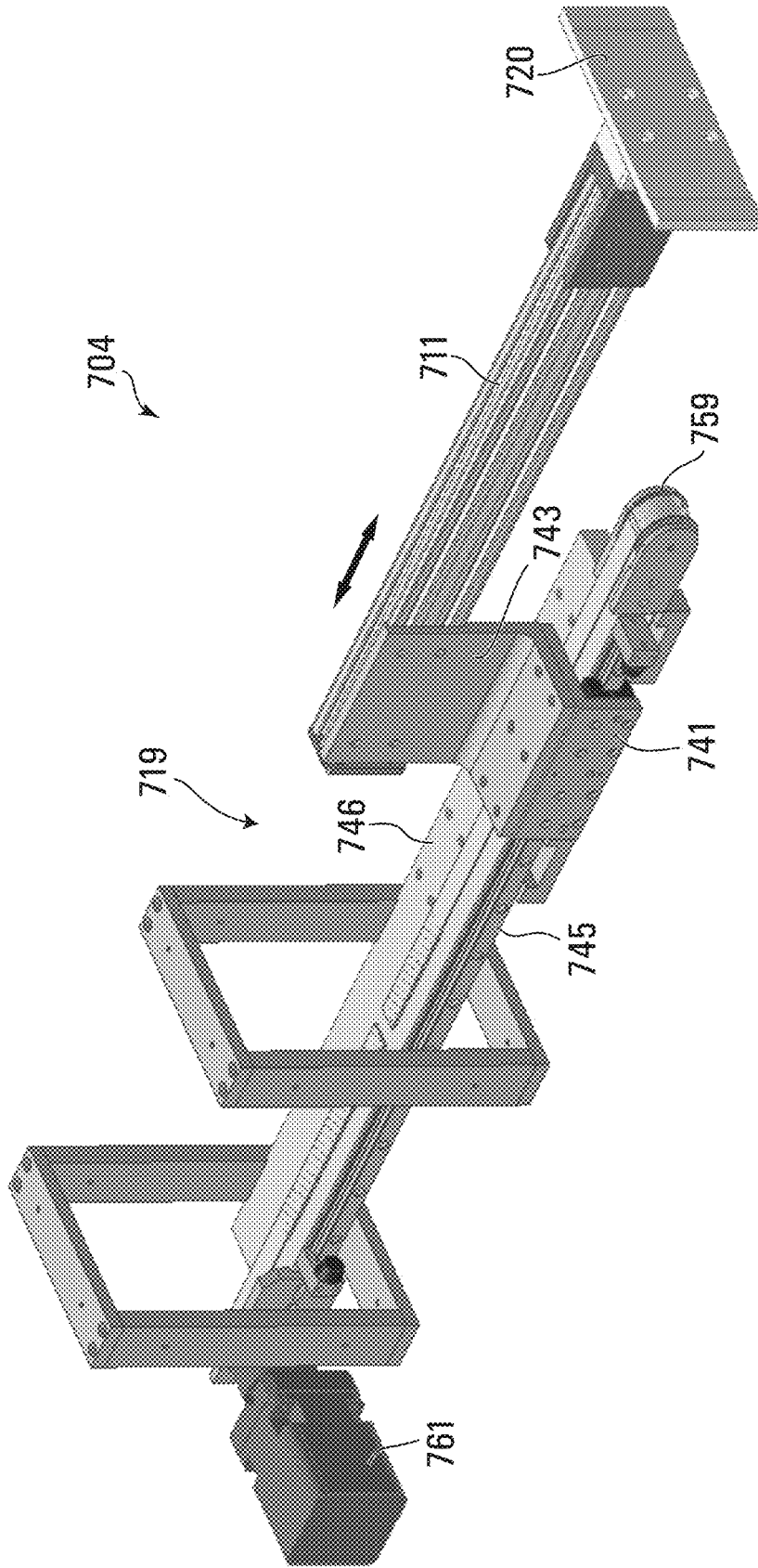

FIG. 26A

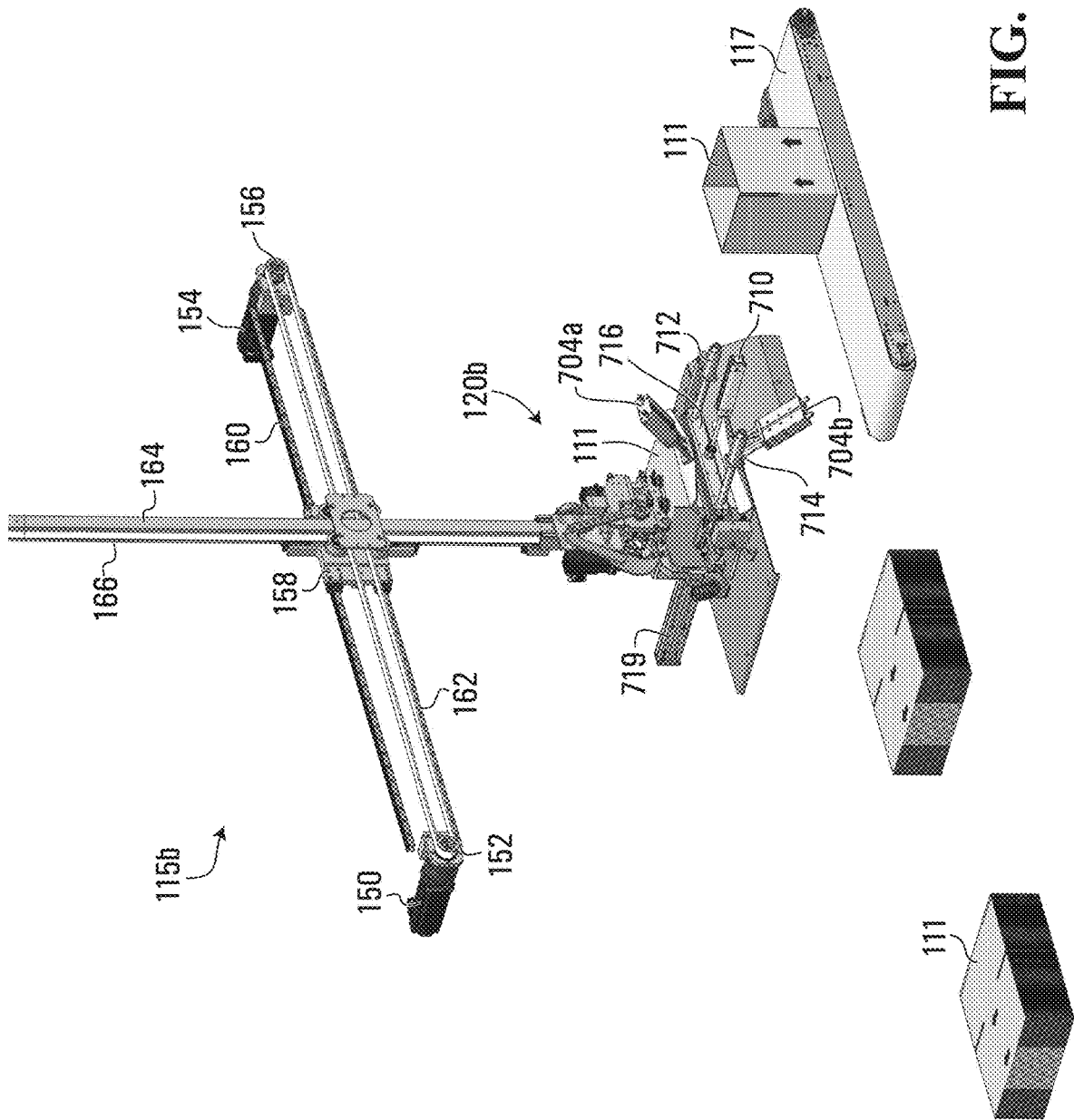

FIG. 27

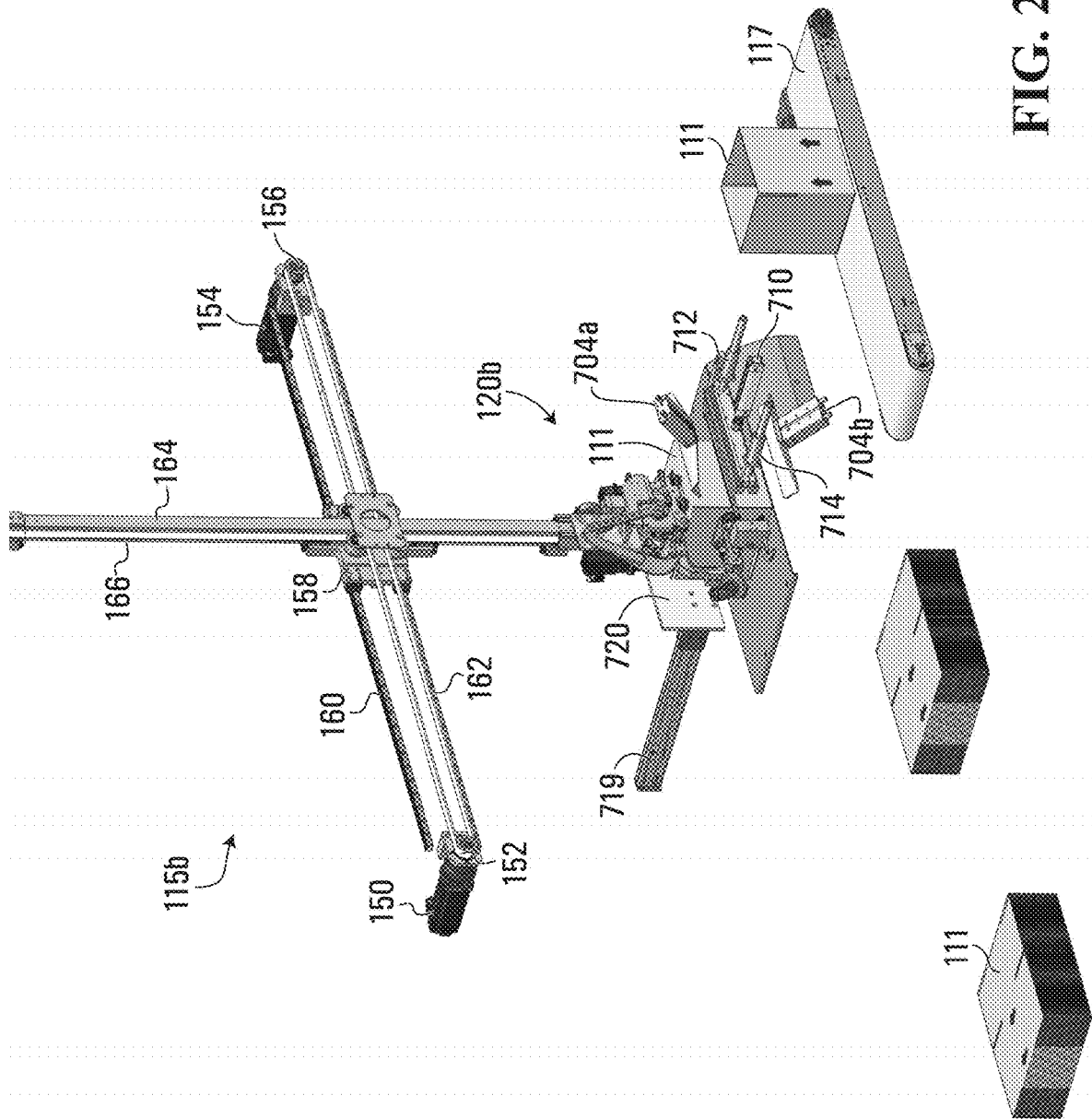

FIG. 28

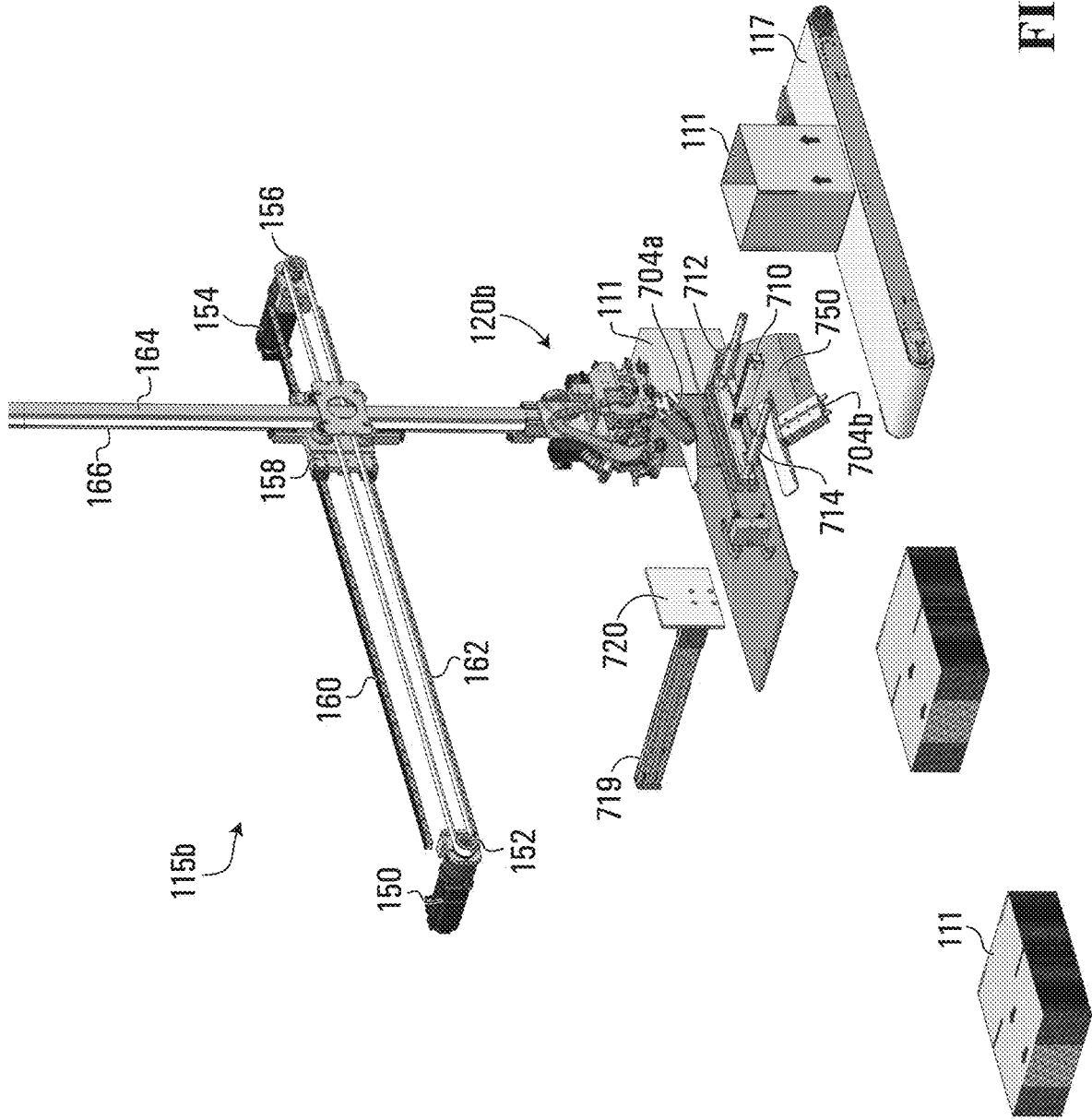

FIG. 29

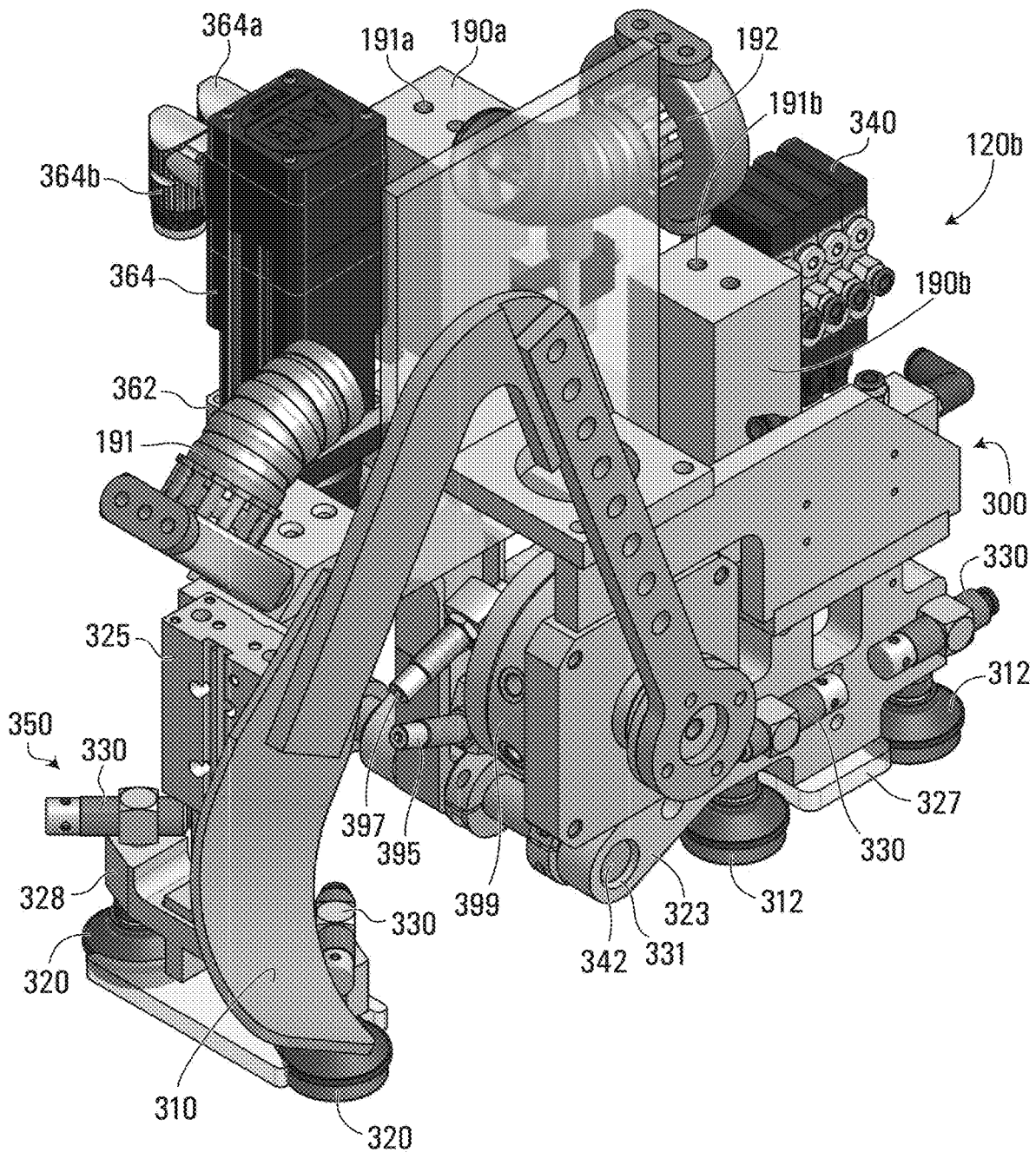

FIG. 30

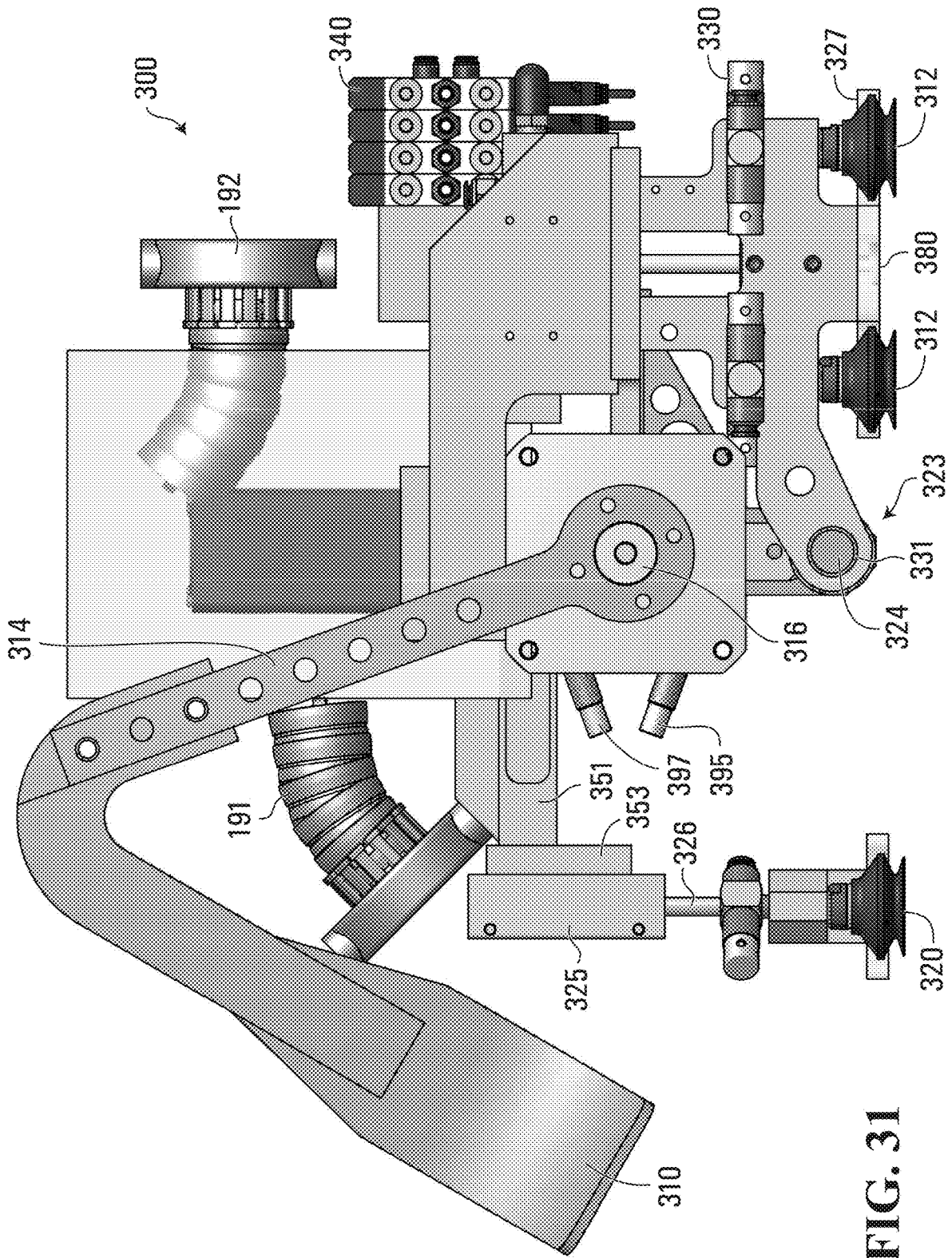

FIG. 31

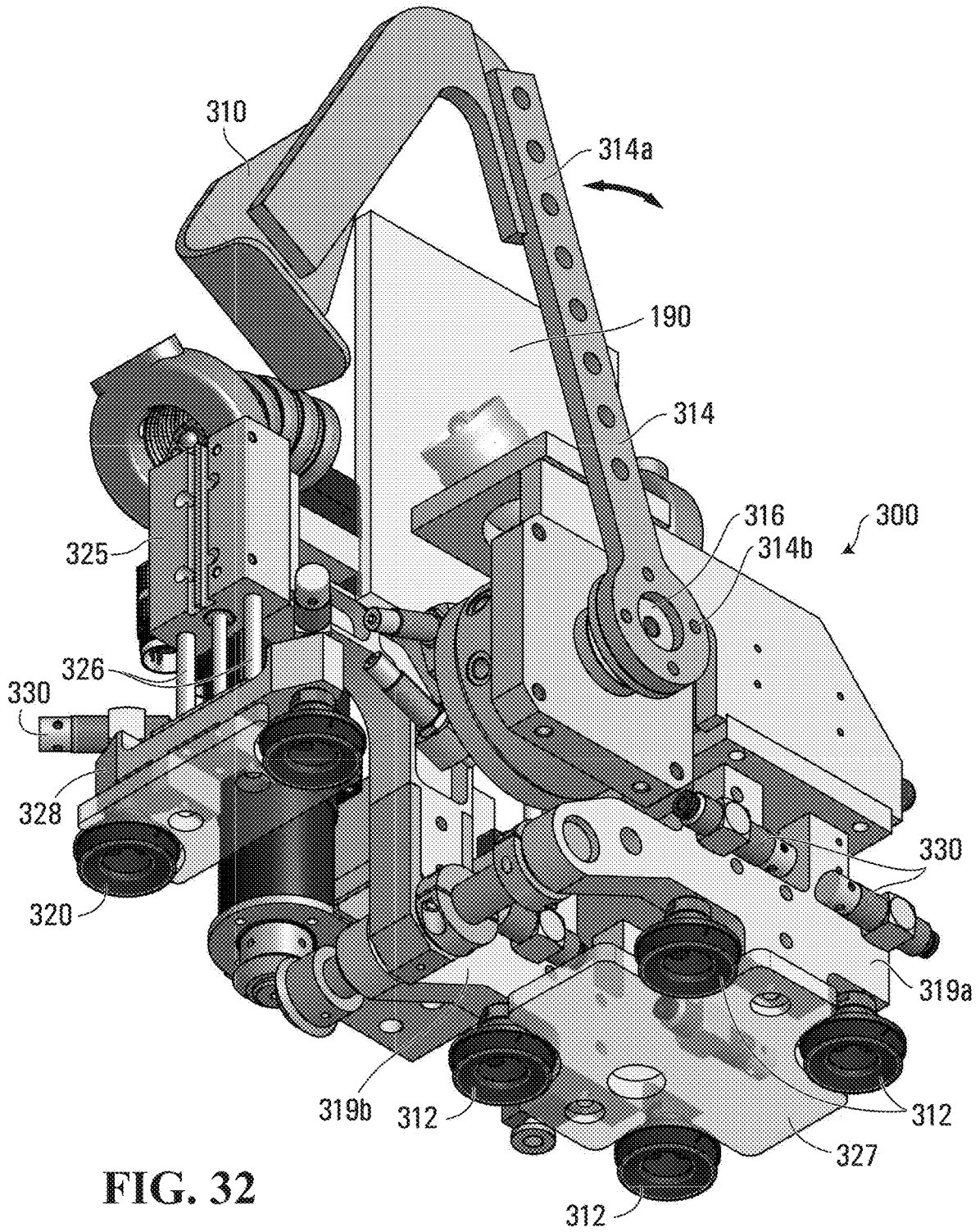

FIG. 32

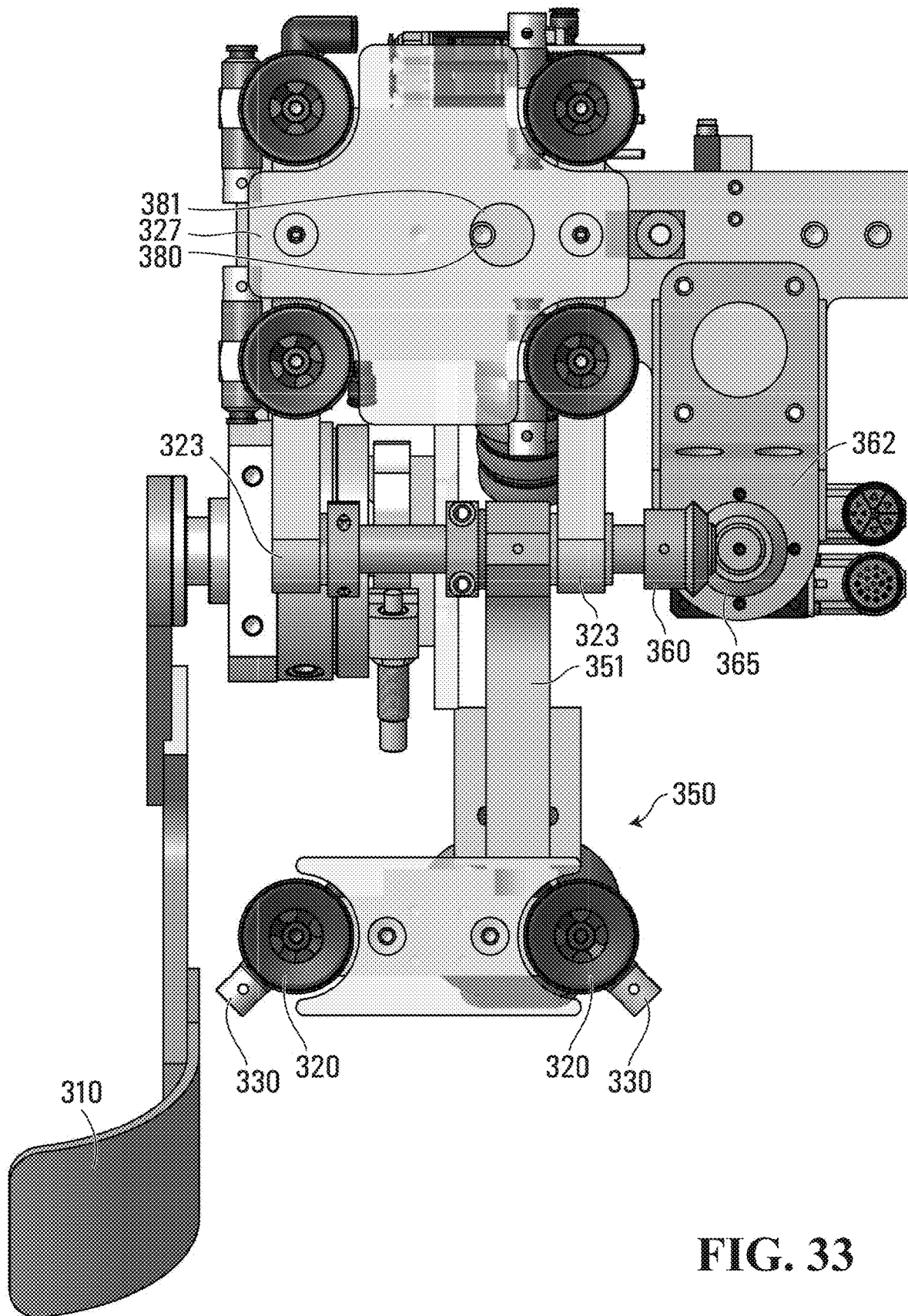

FIG. 33

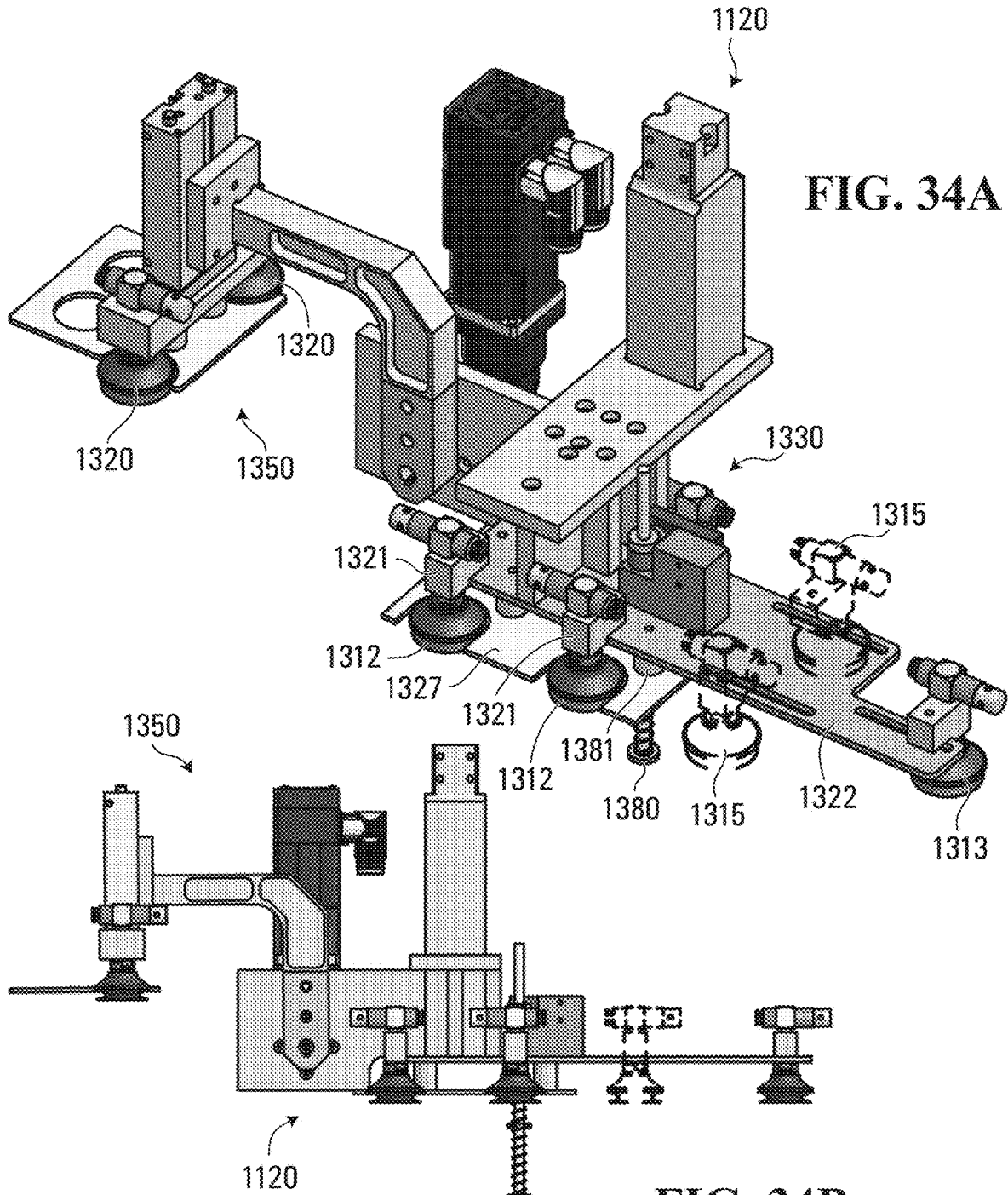

FIG. 34A

FIG. 34B

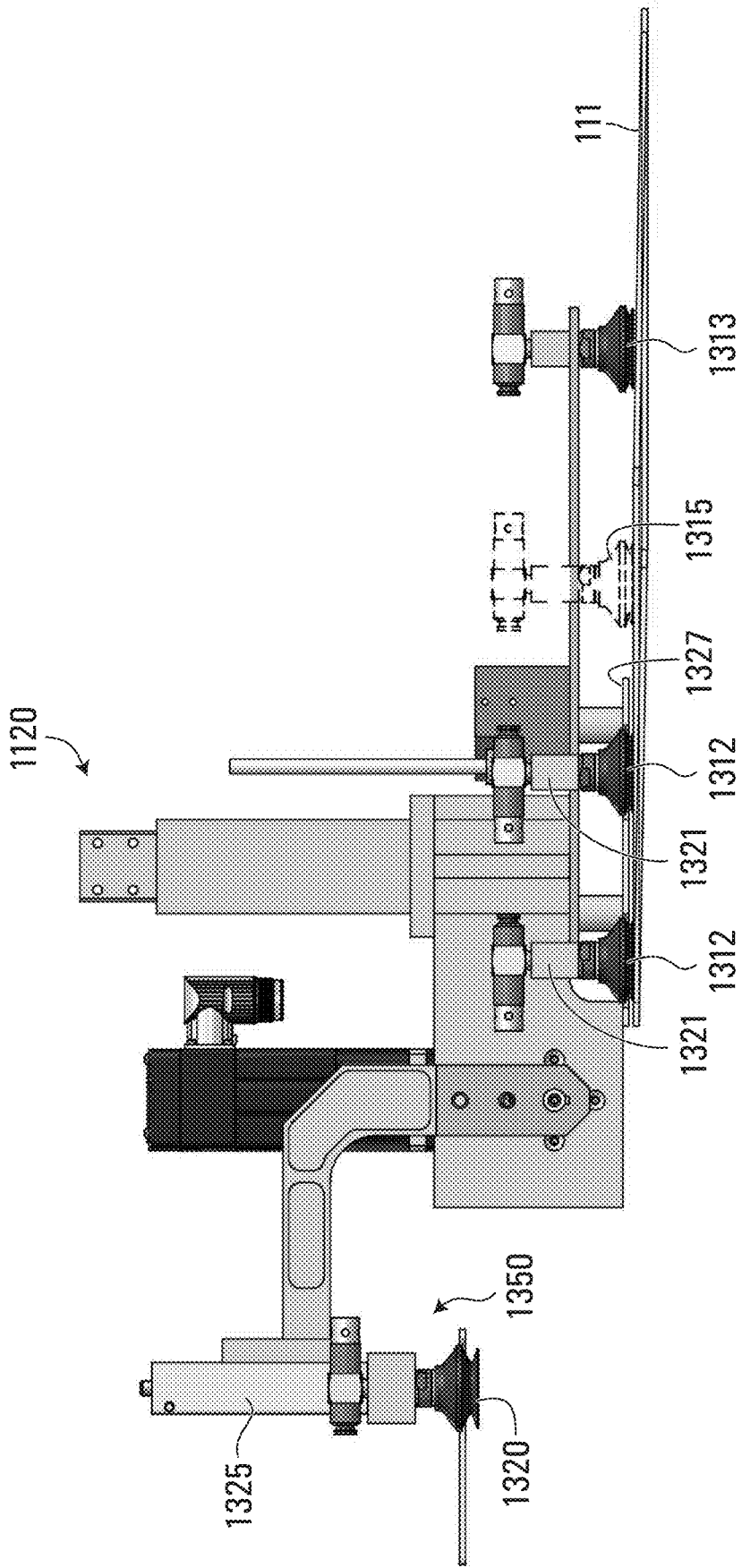

FIG. 35A

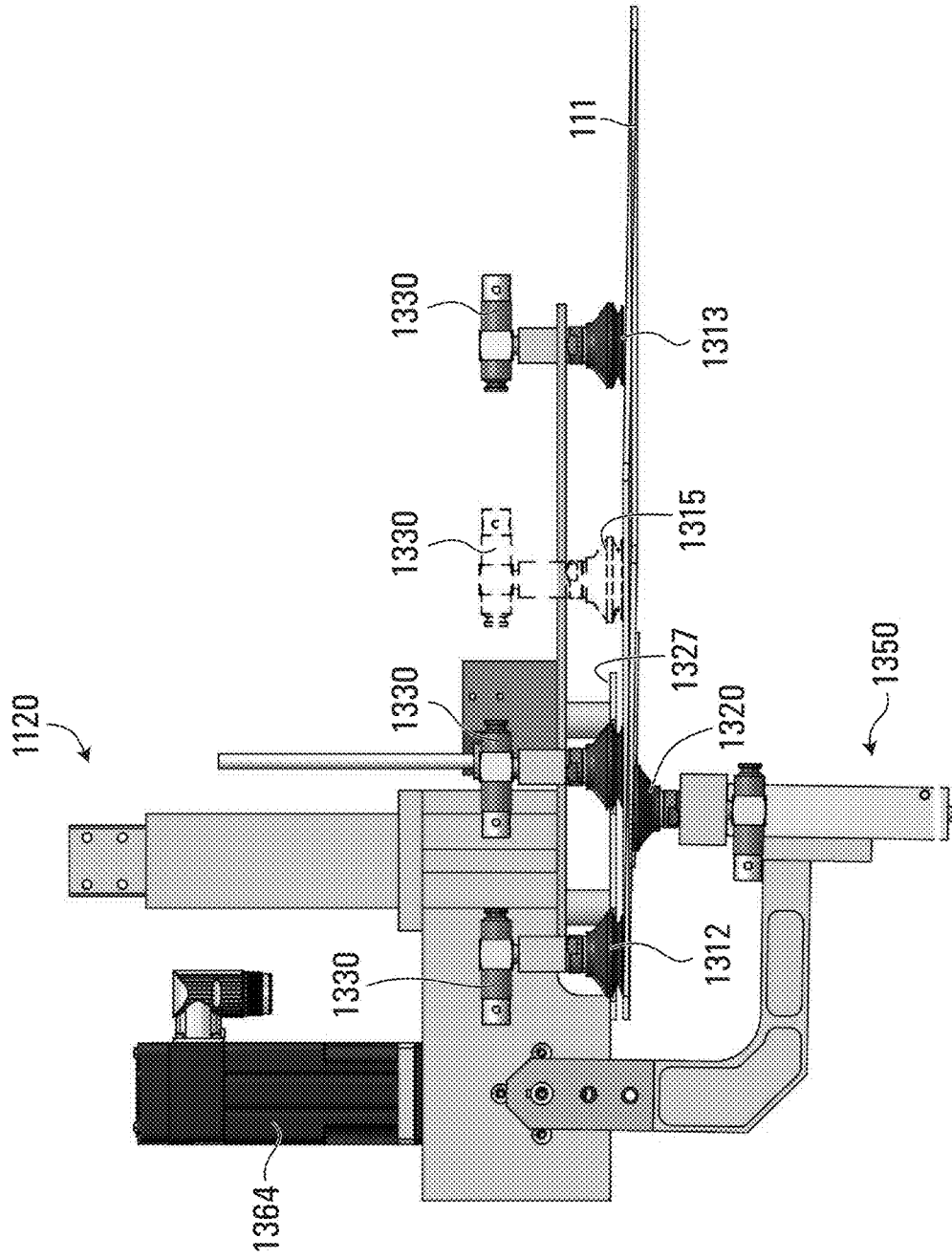

FIG. 35B

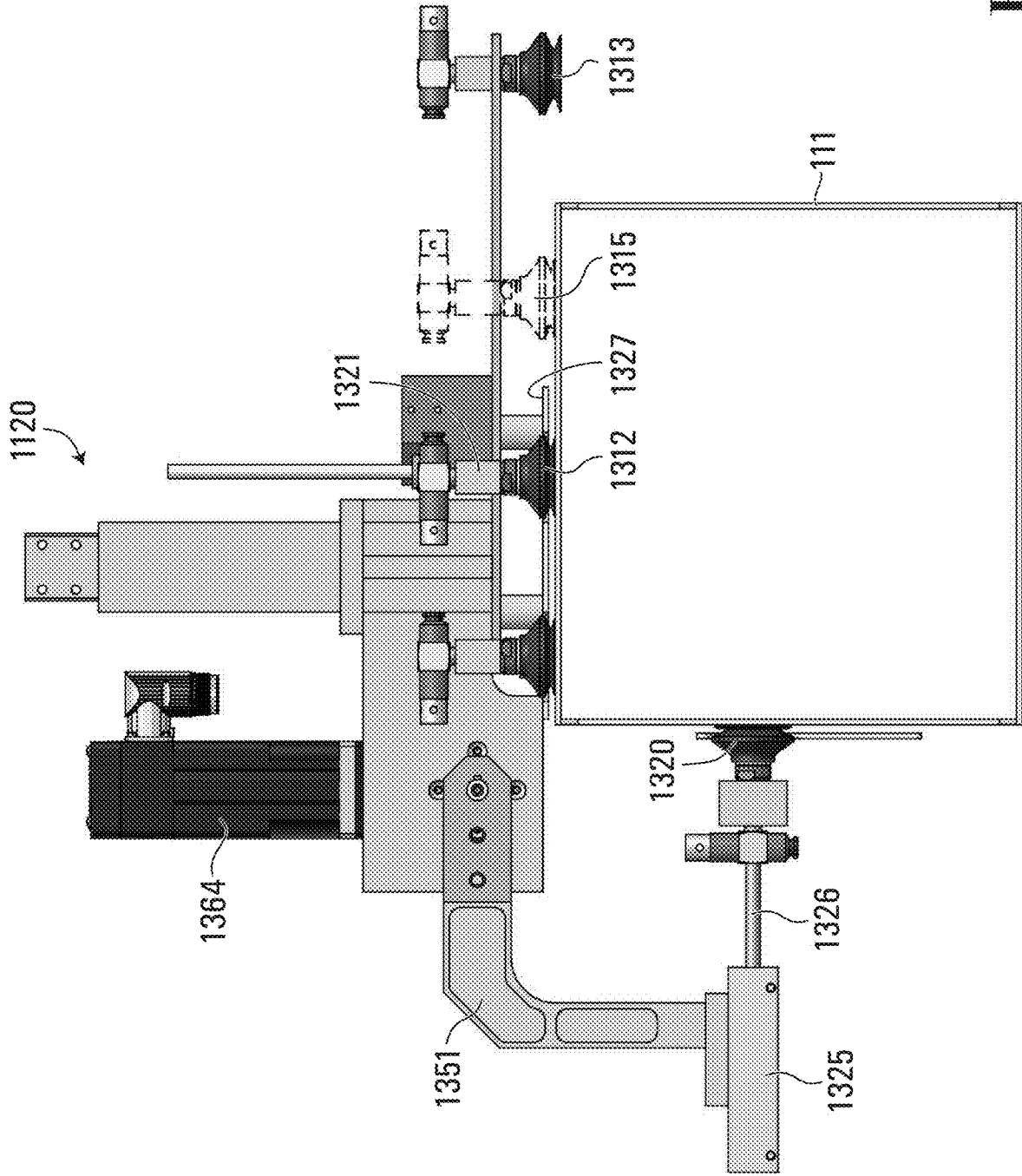

FIG. 35C

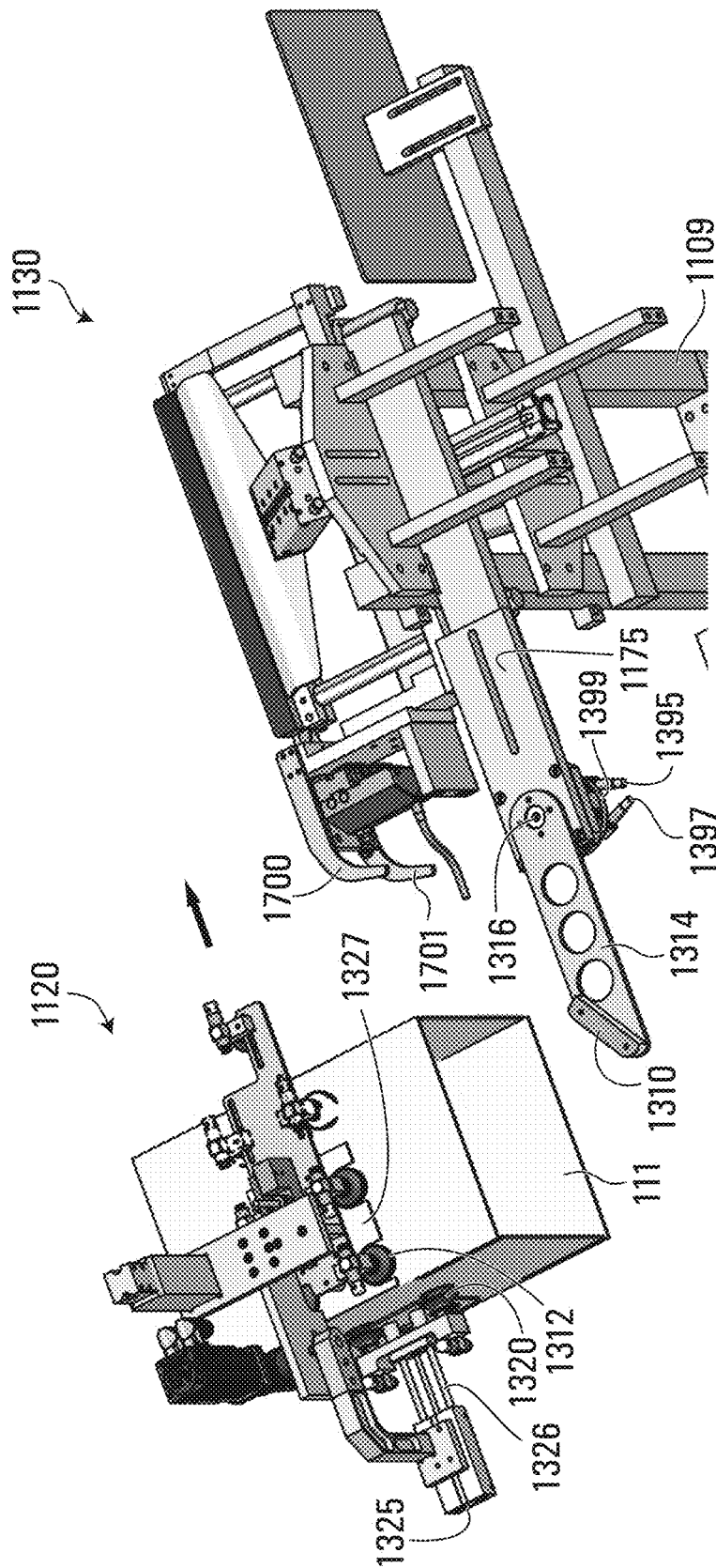

FIG. 36

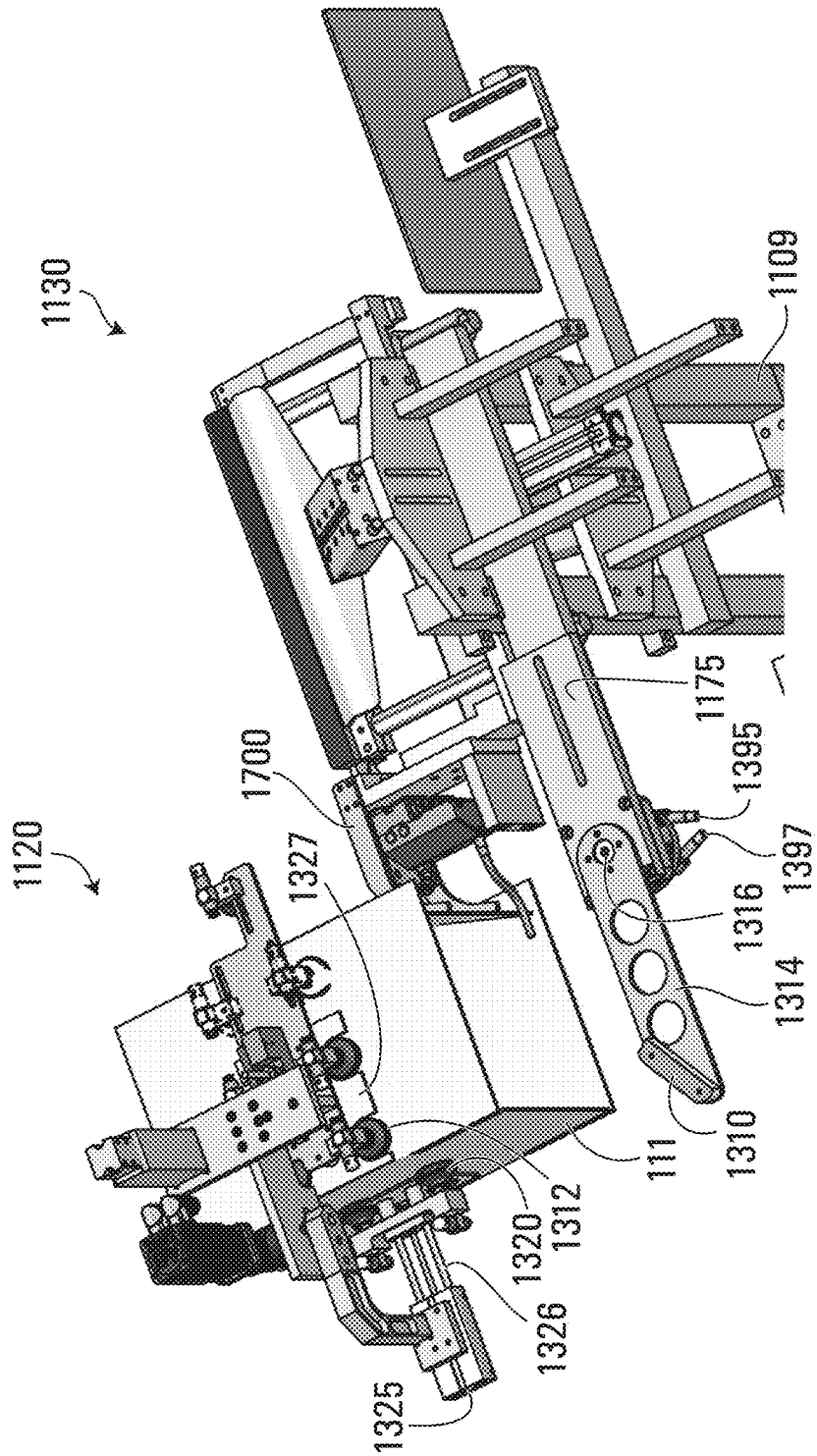

FIG. 37

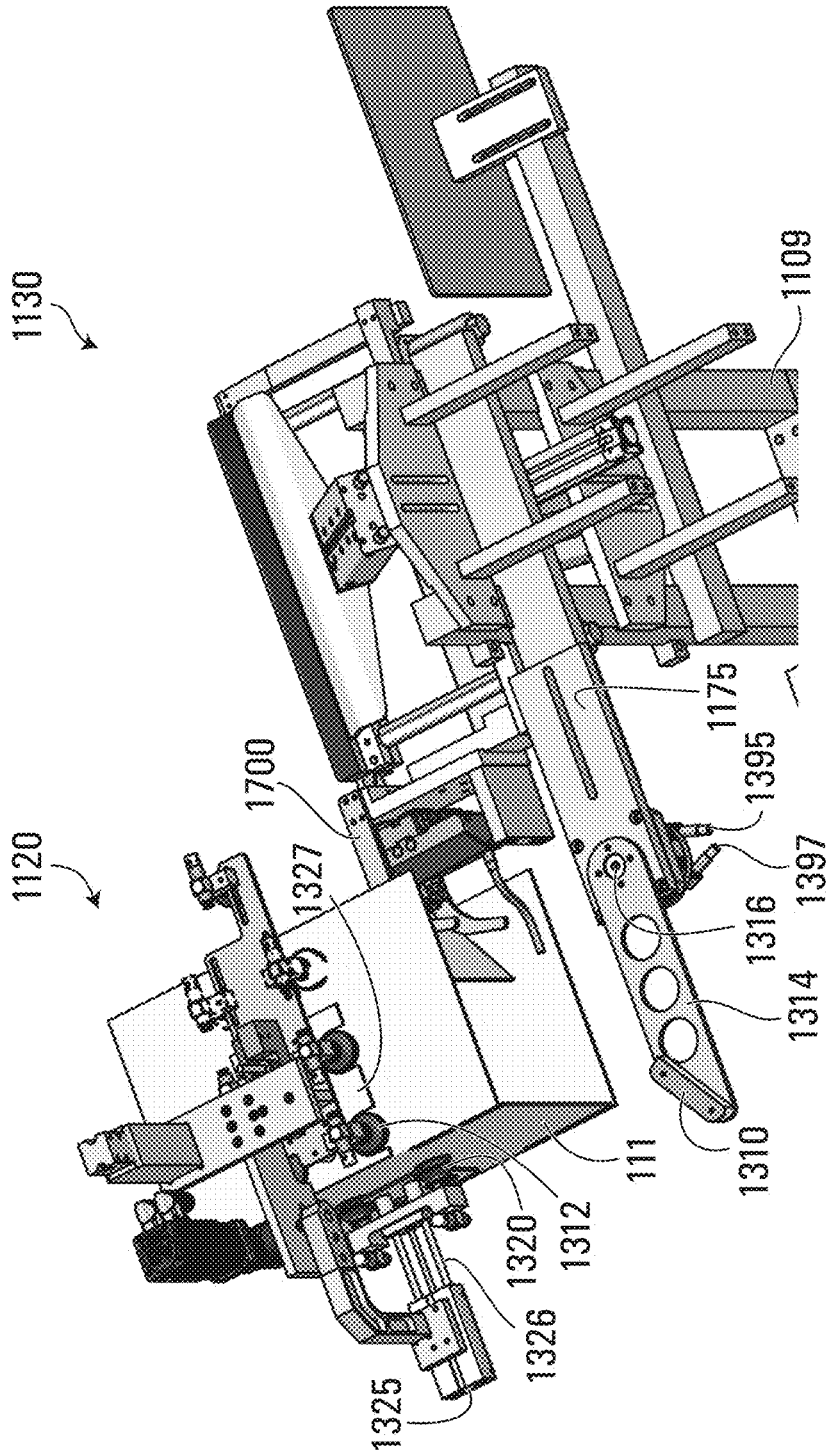

FIG. 38

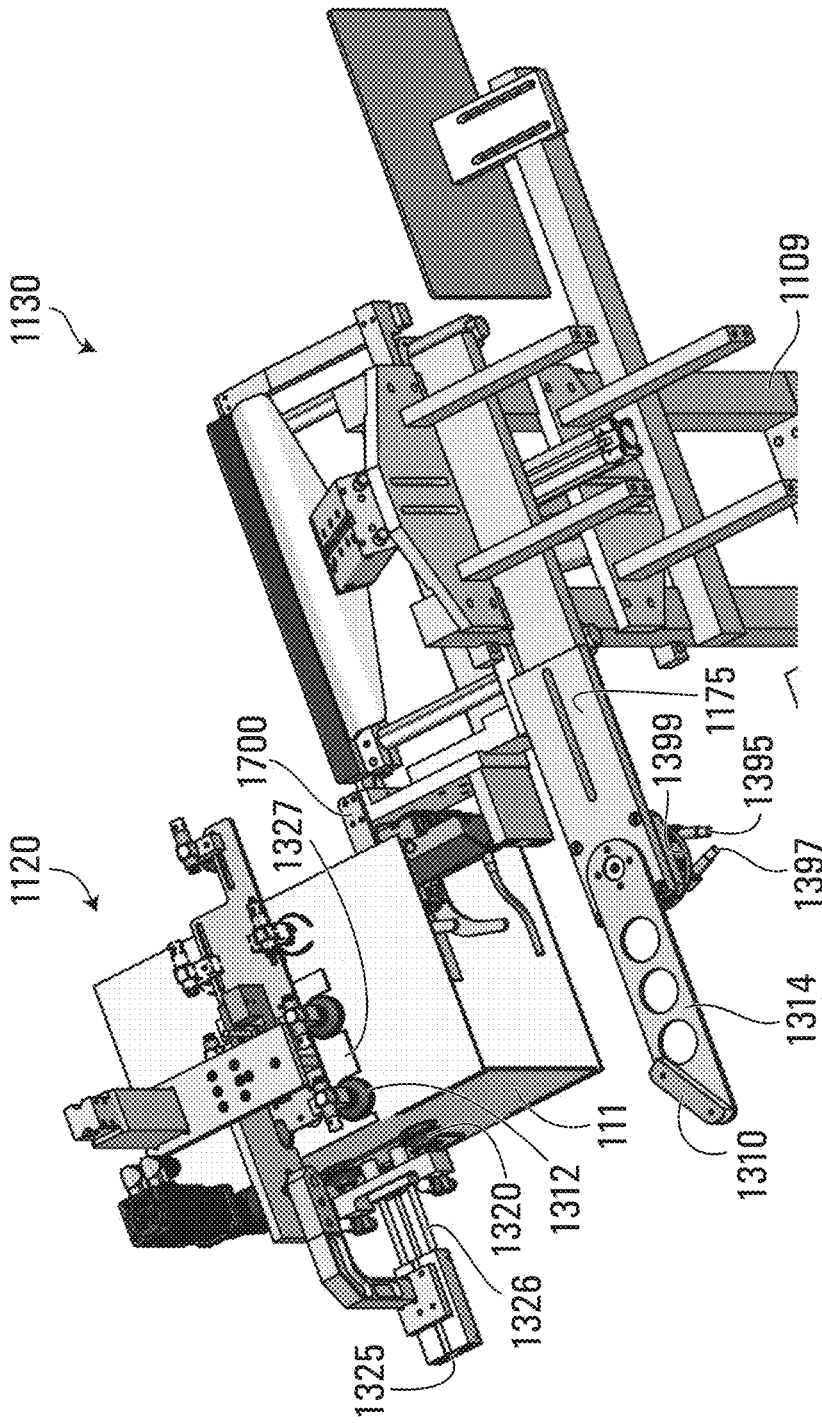

FIG. 39

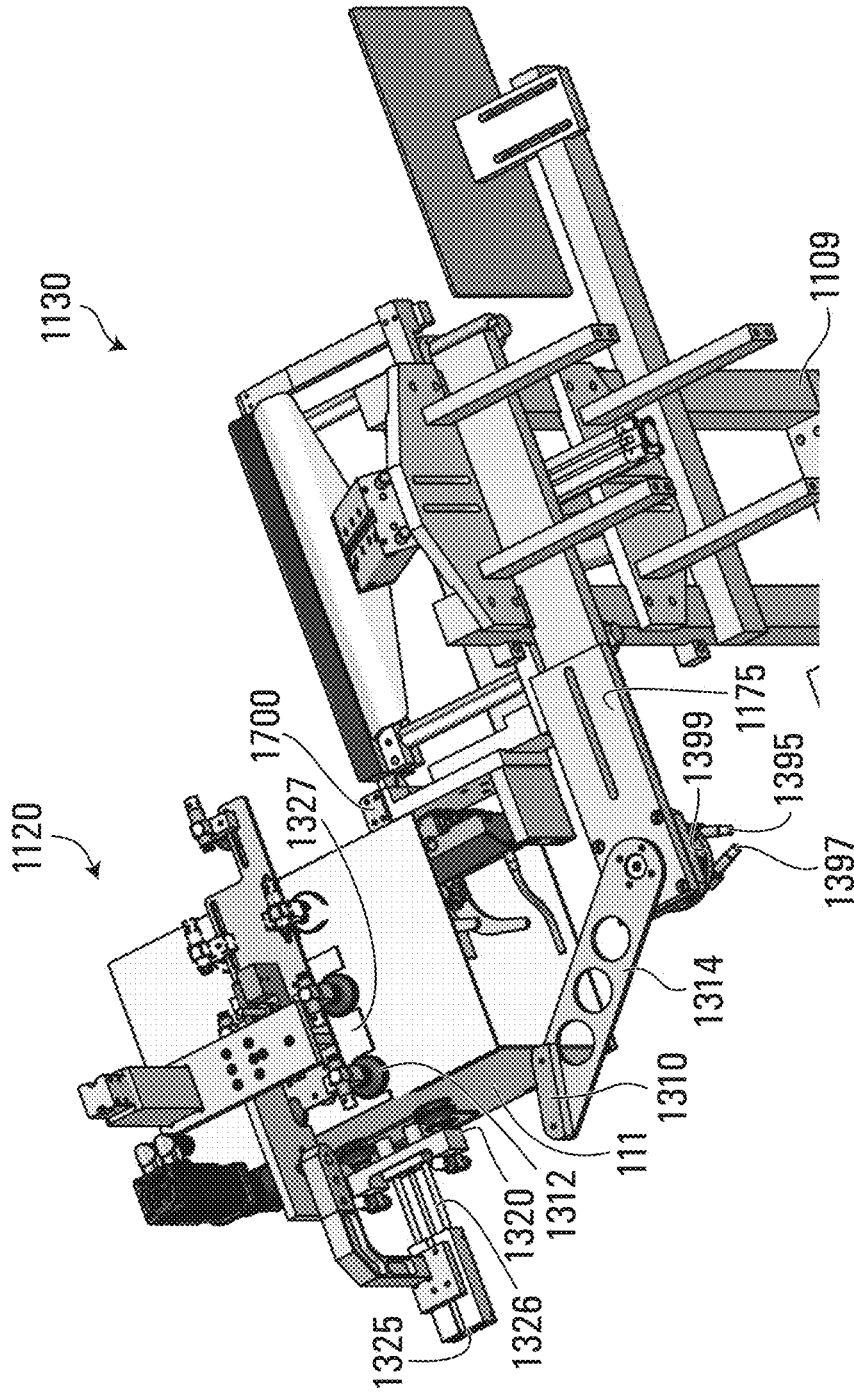

FIG. 40

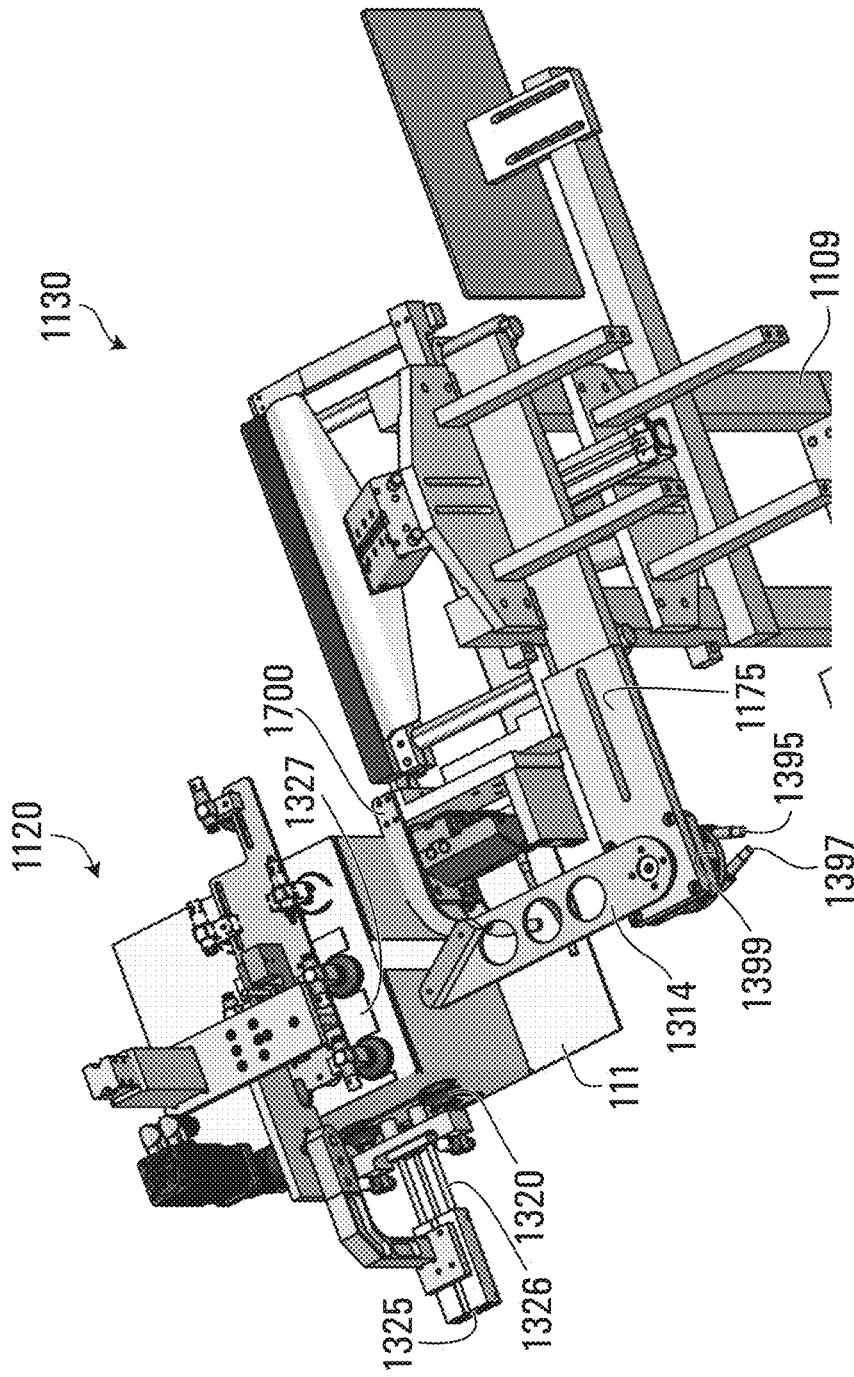

FIG. 41

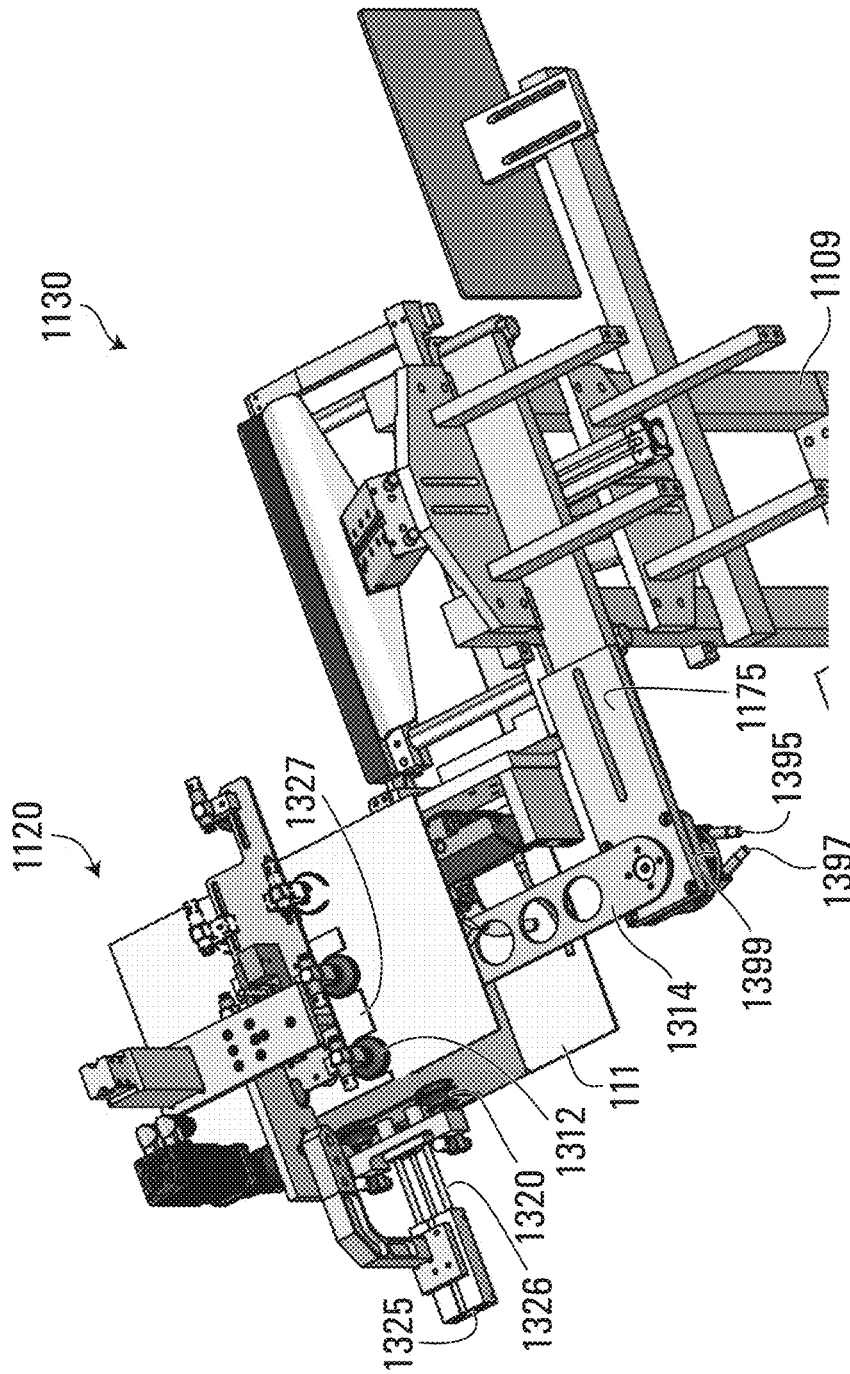

FIG. 42

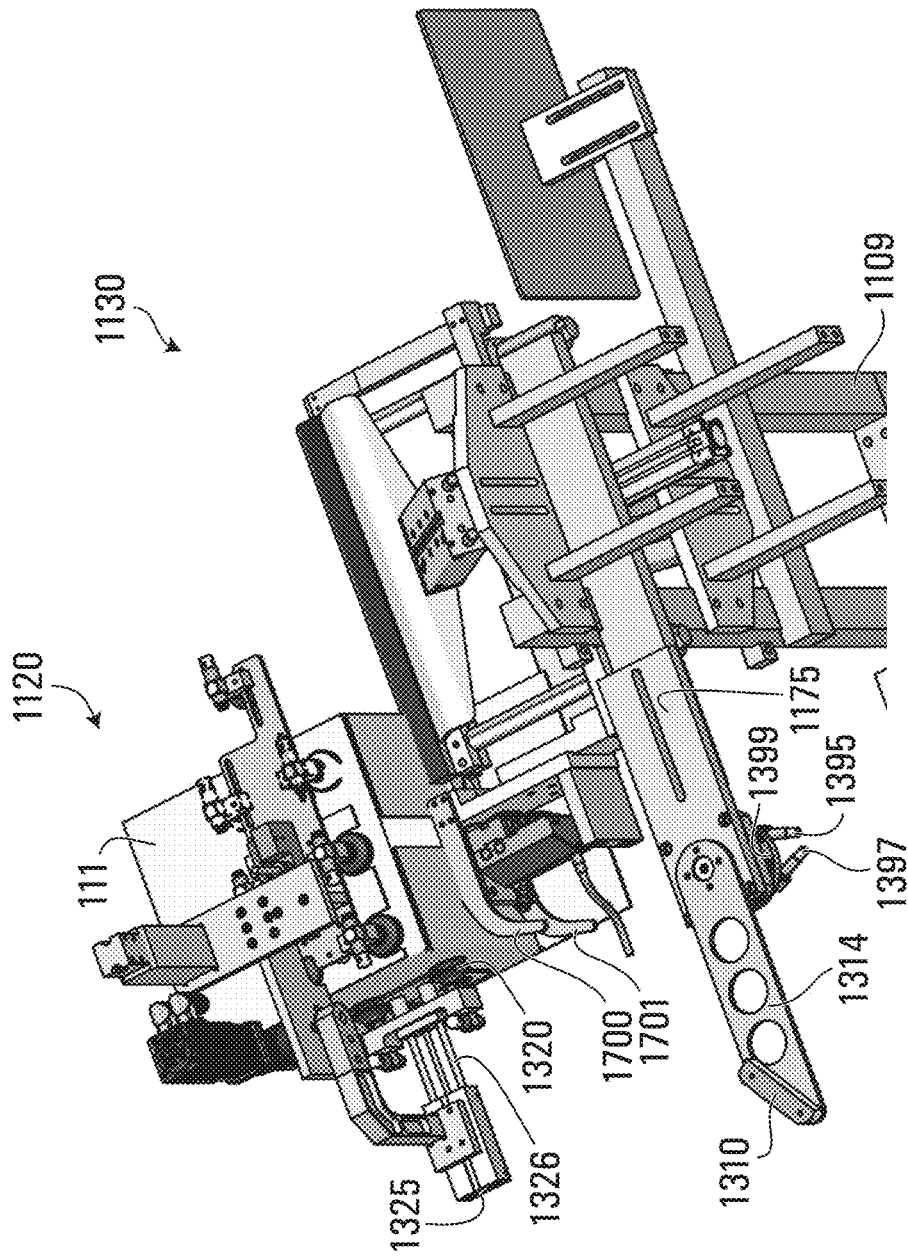

FIG. 43

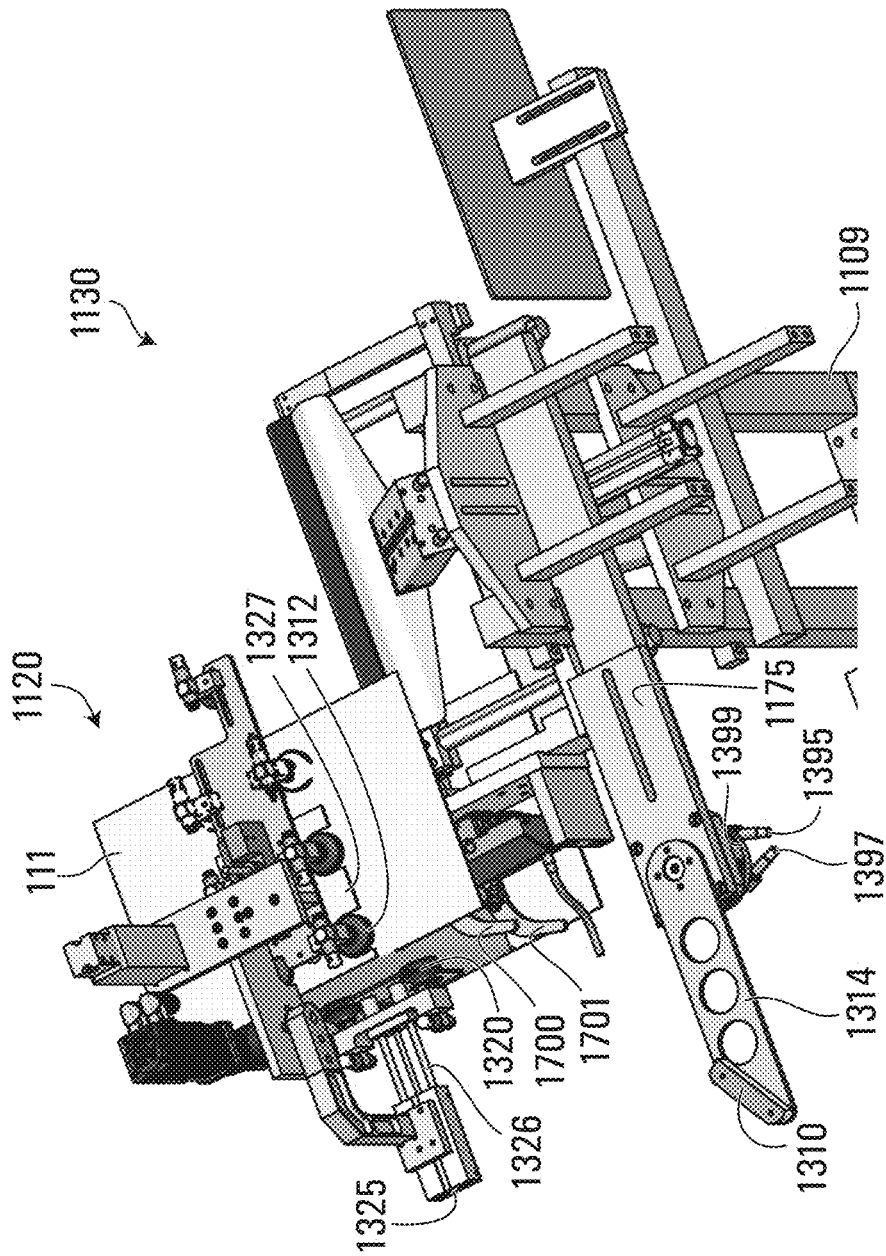
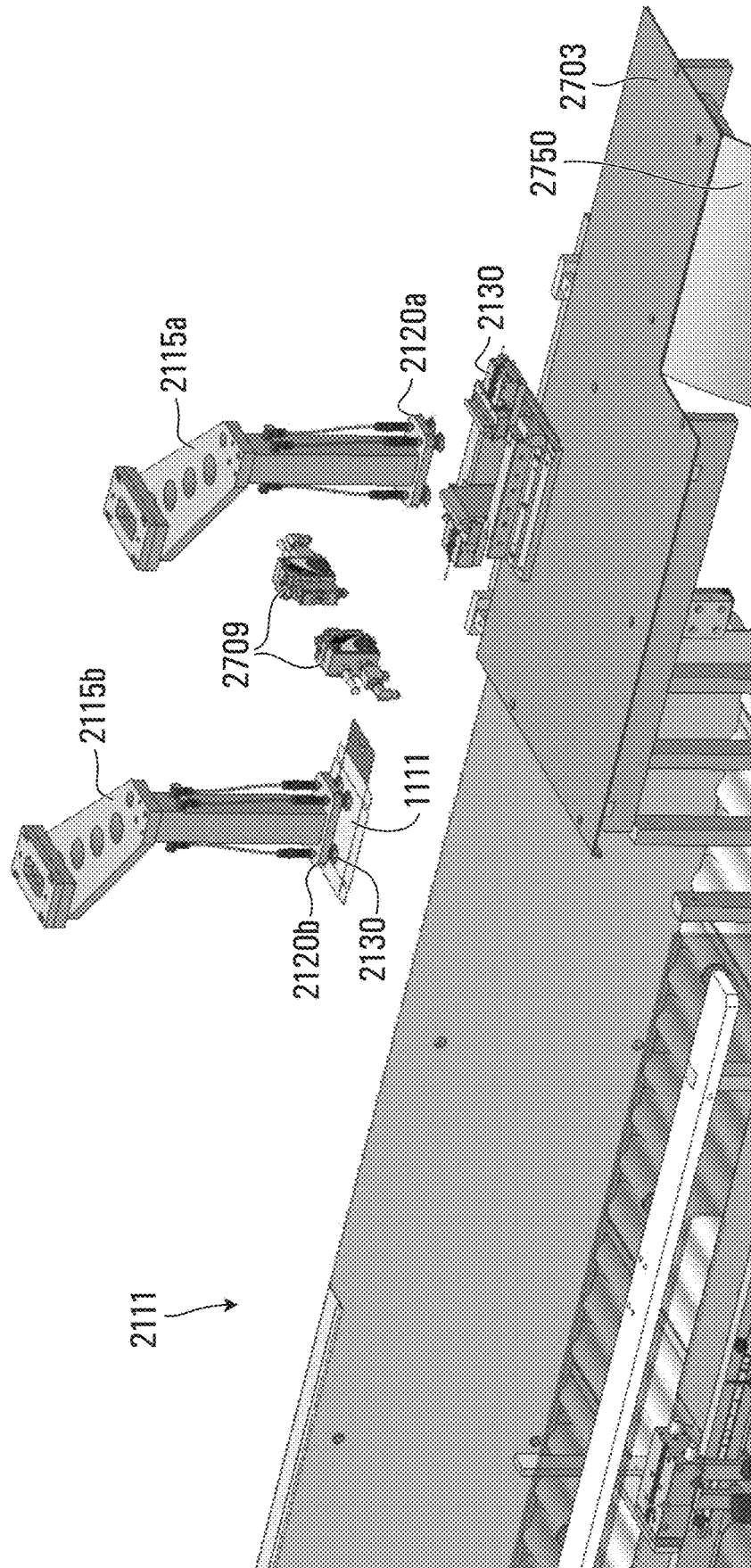

FIG. 44

FIG. 45



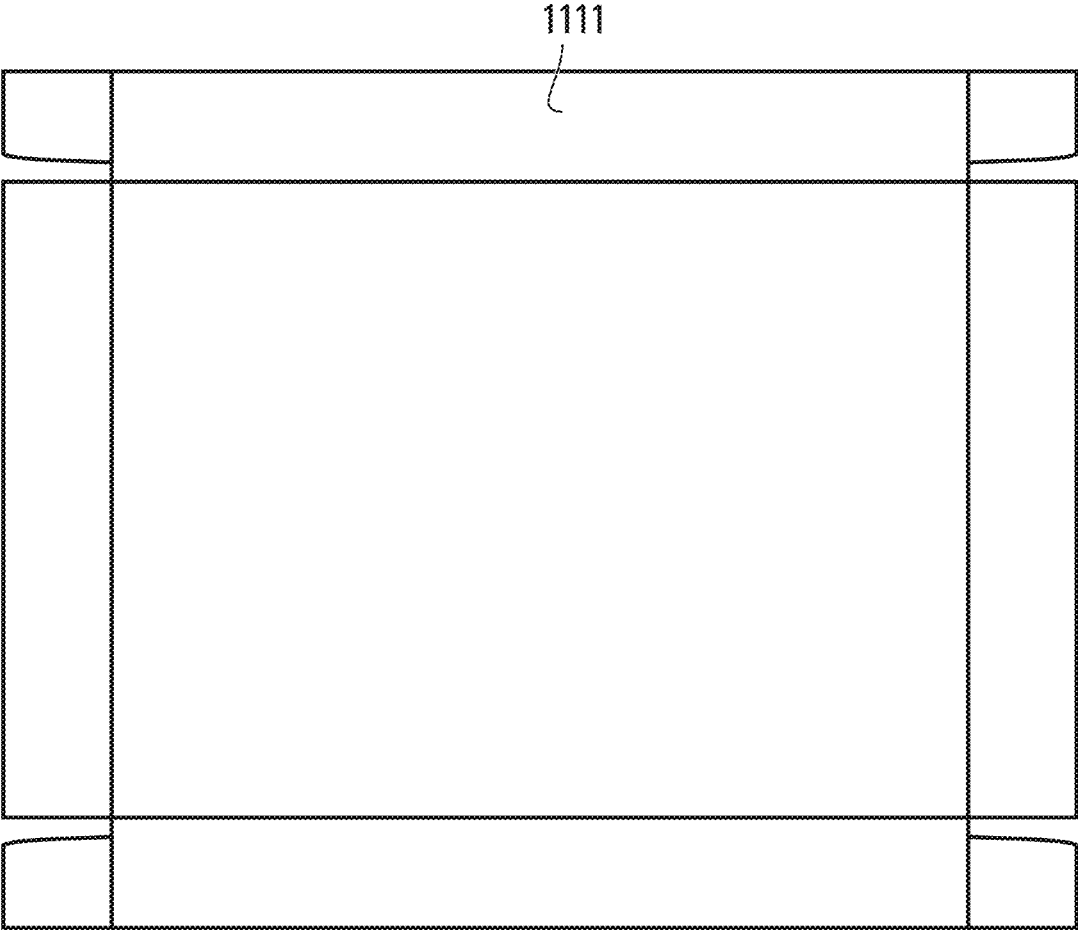

FIG. 46

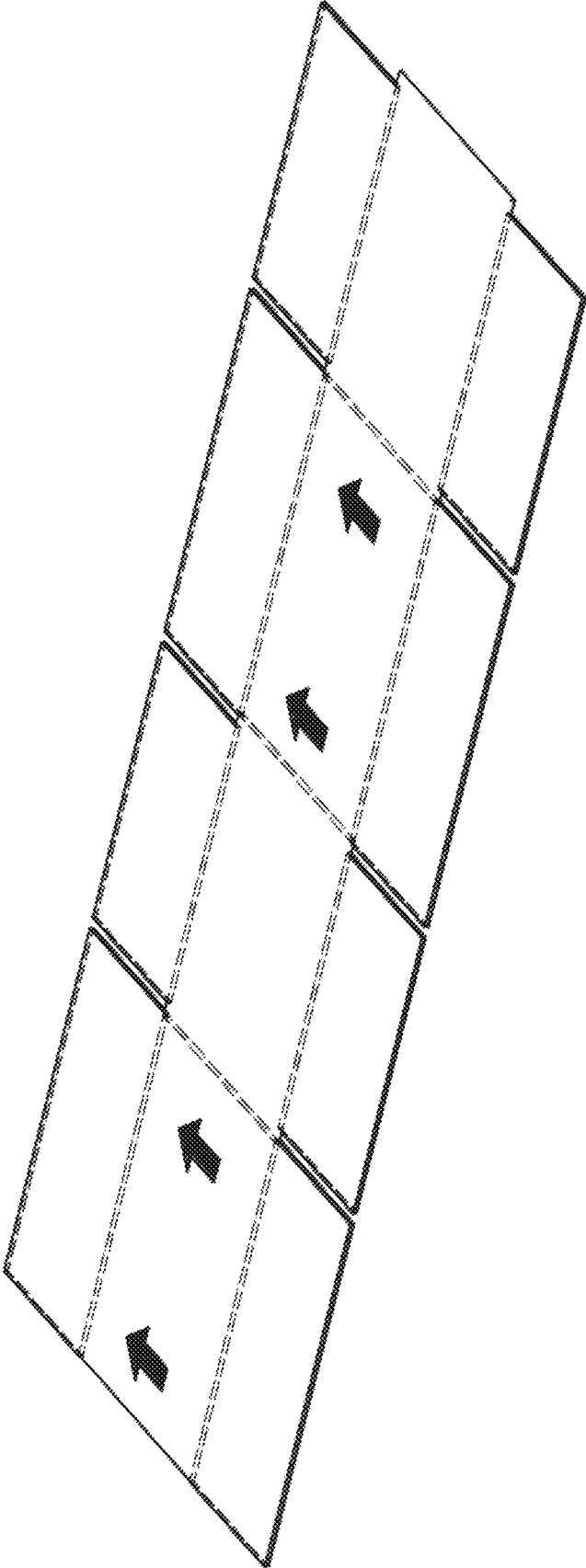

FIG. 47

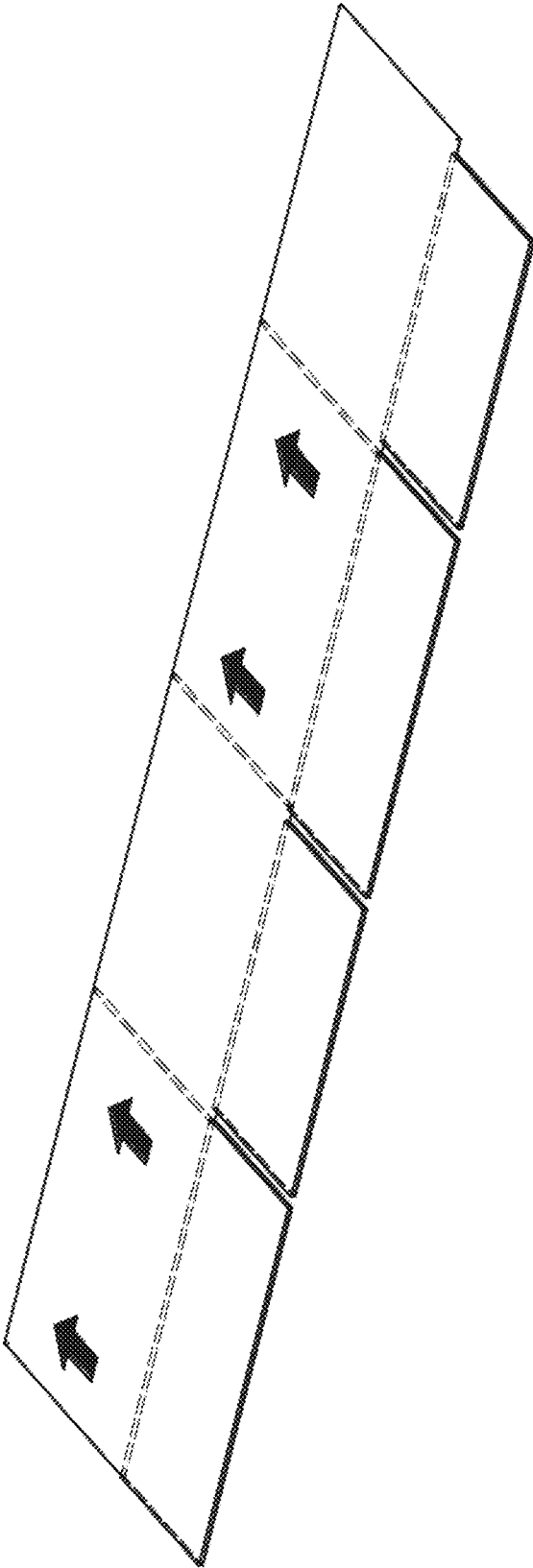

FIG. 48

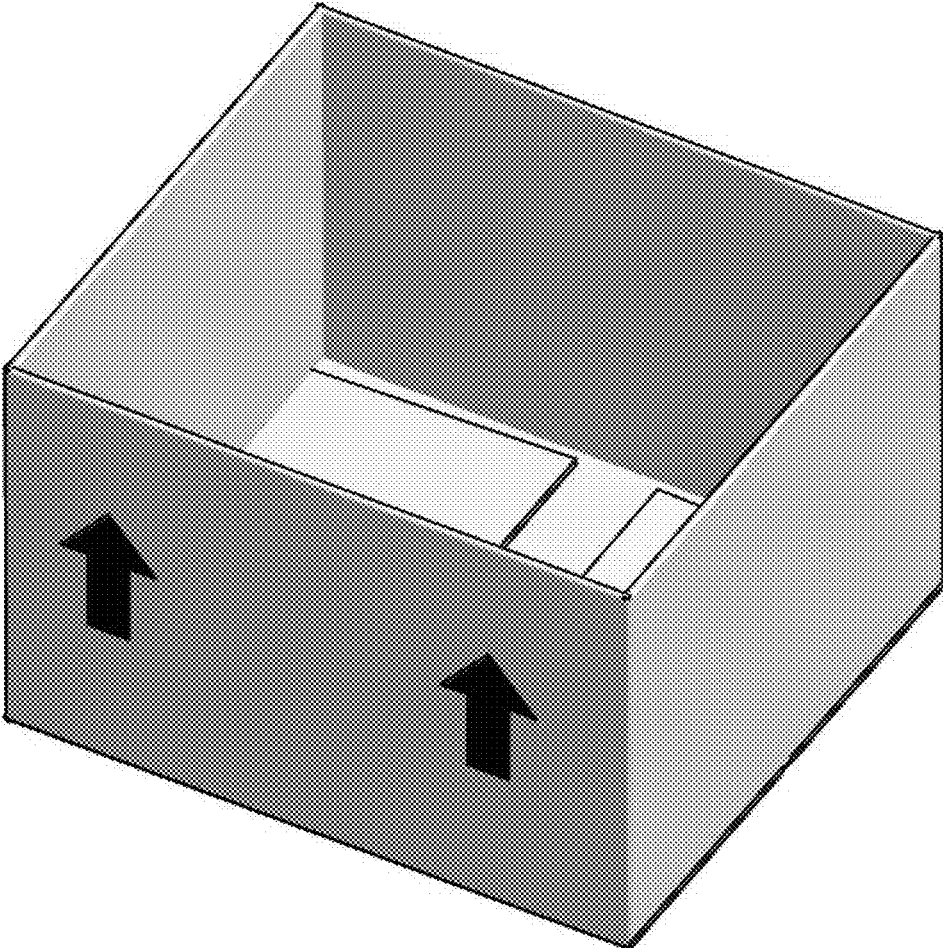

FIG. 49

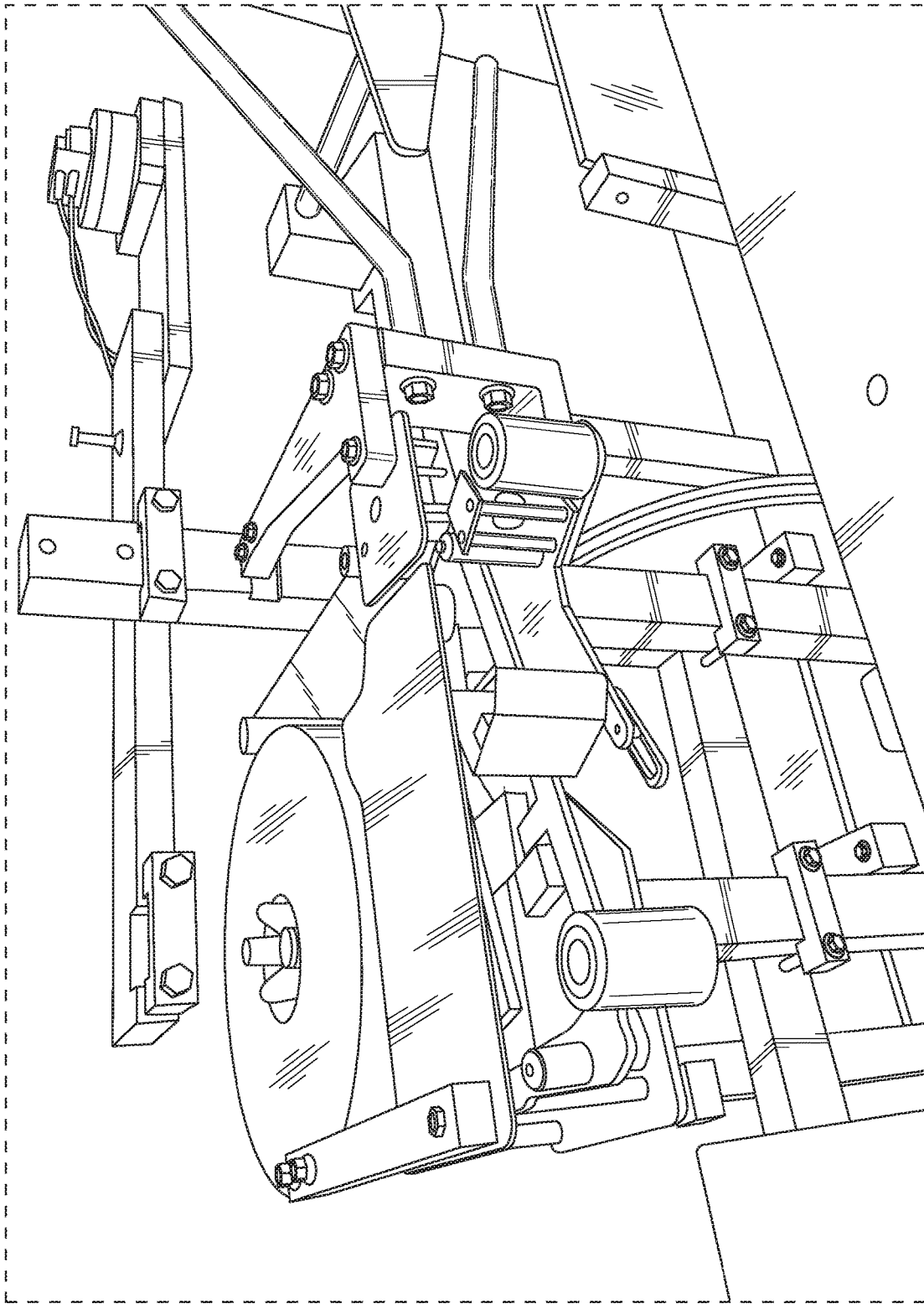

FIG. 50

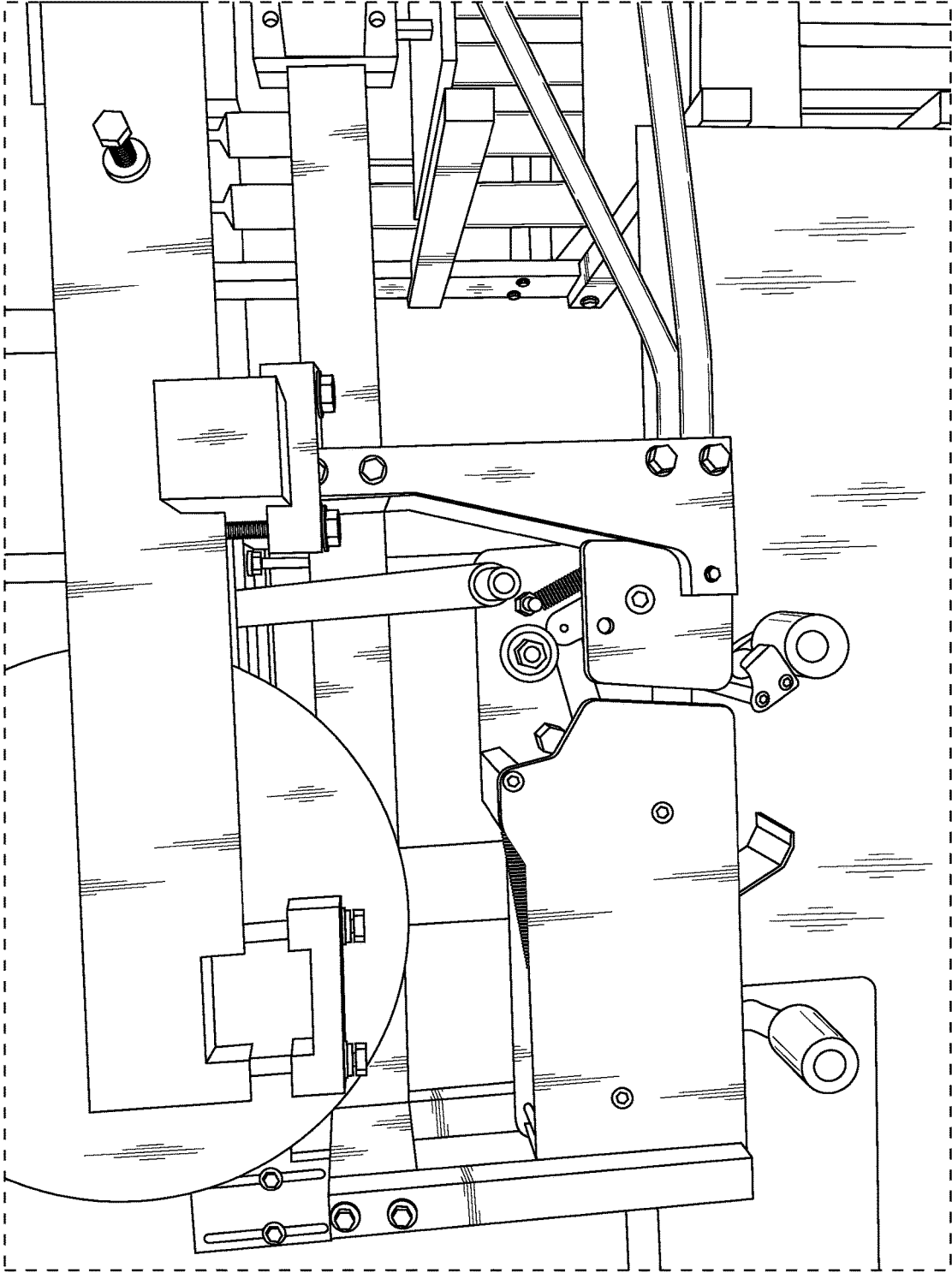

FIG. 51

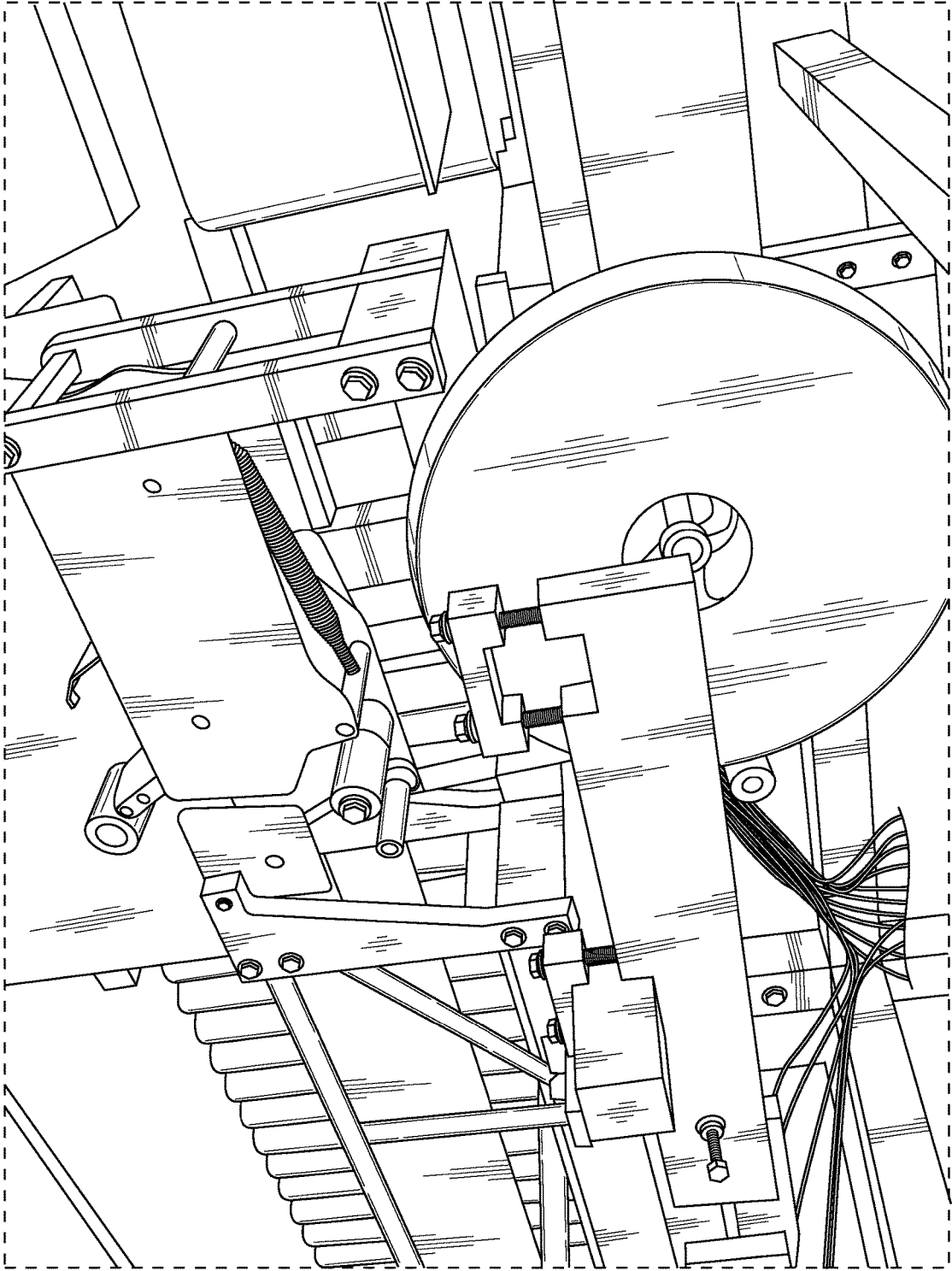

FIG. 52

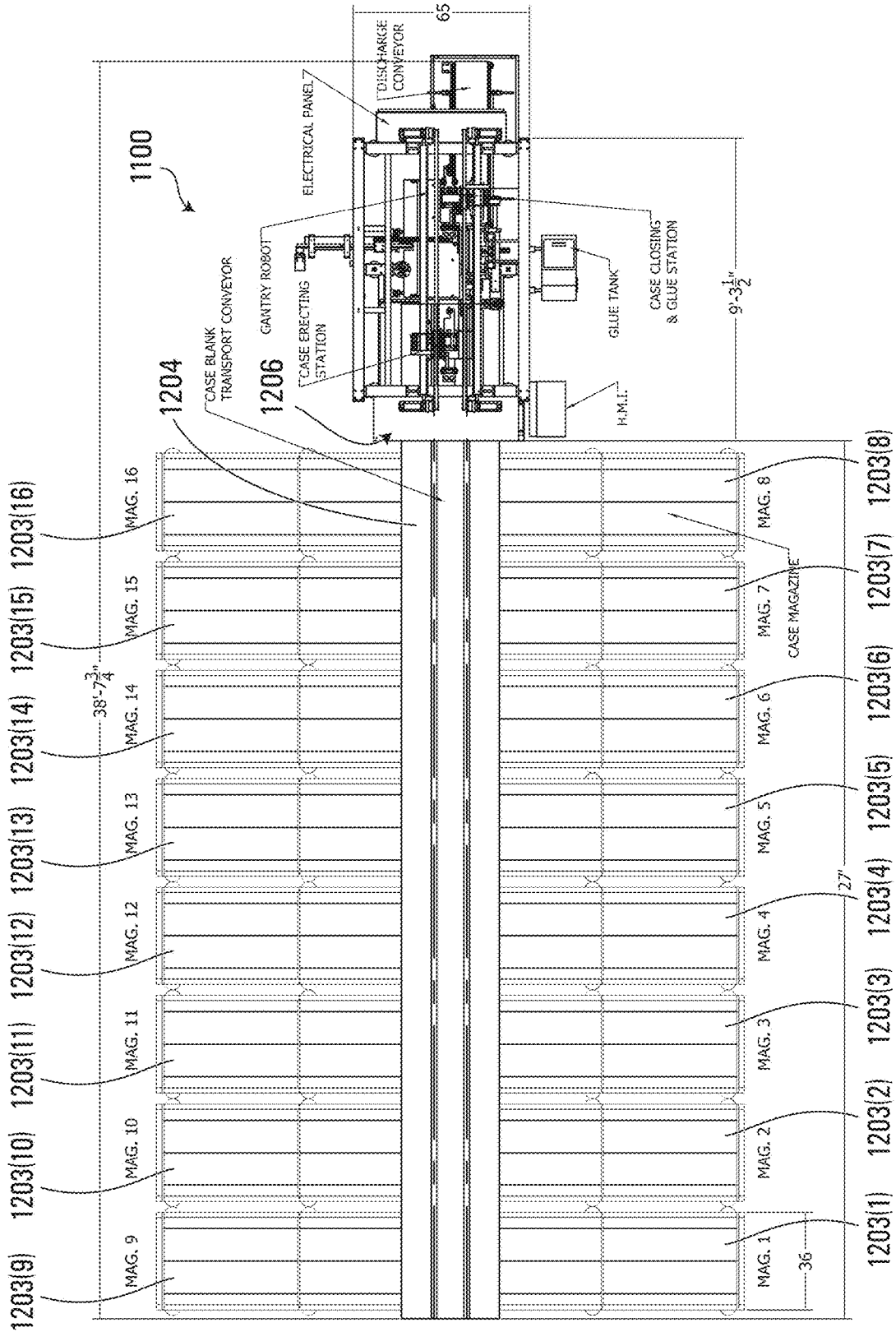

FIG. 53

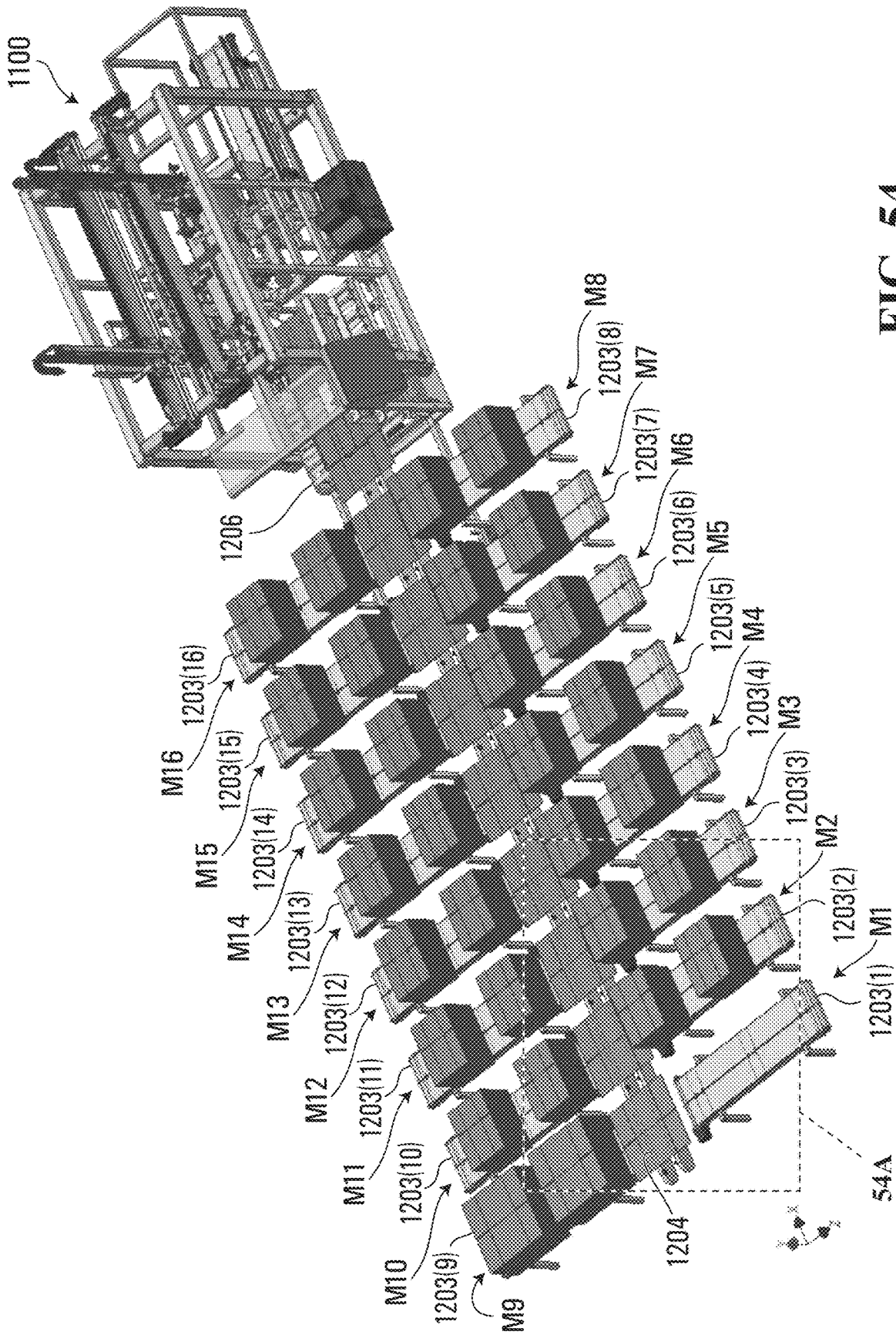

FIG. 54

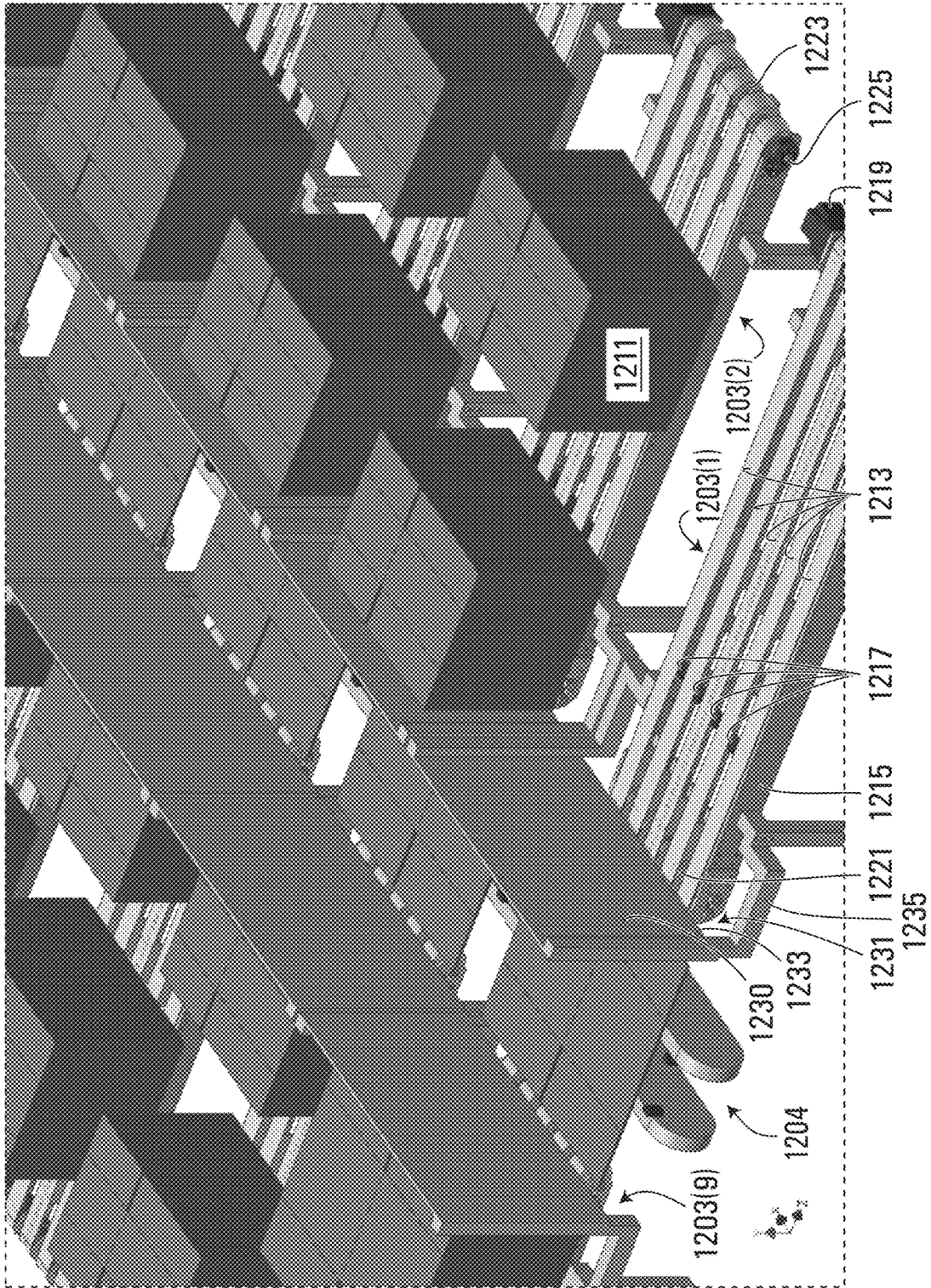

FIG. 54A

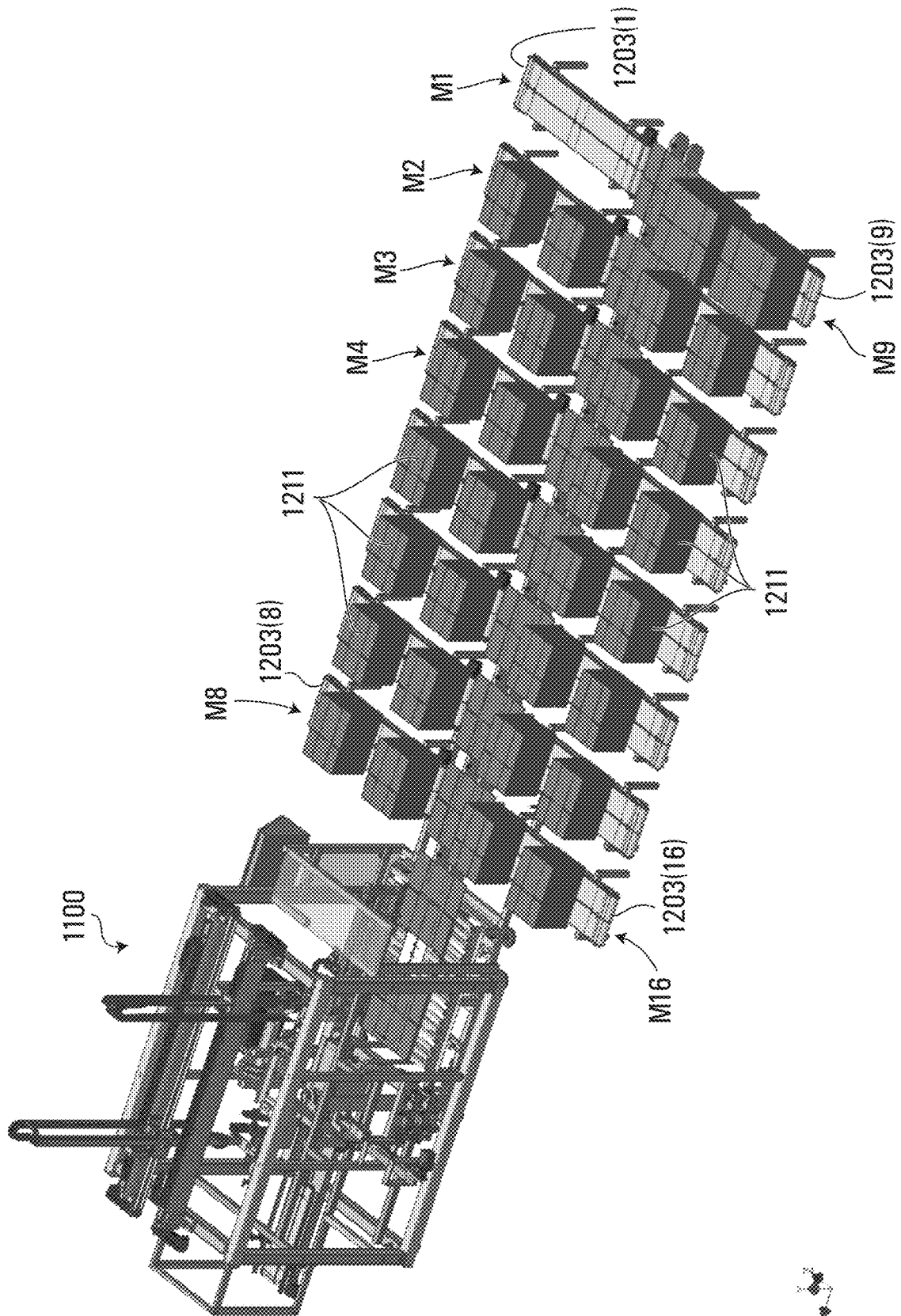

FIG. 55

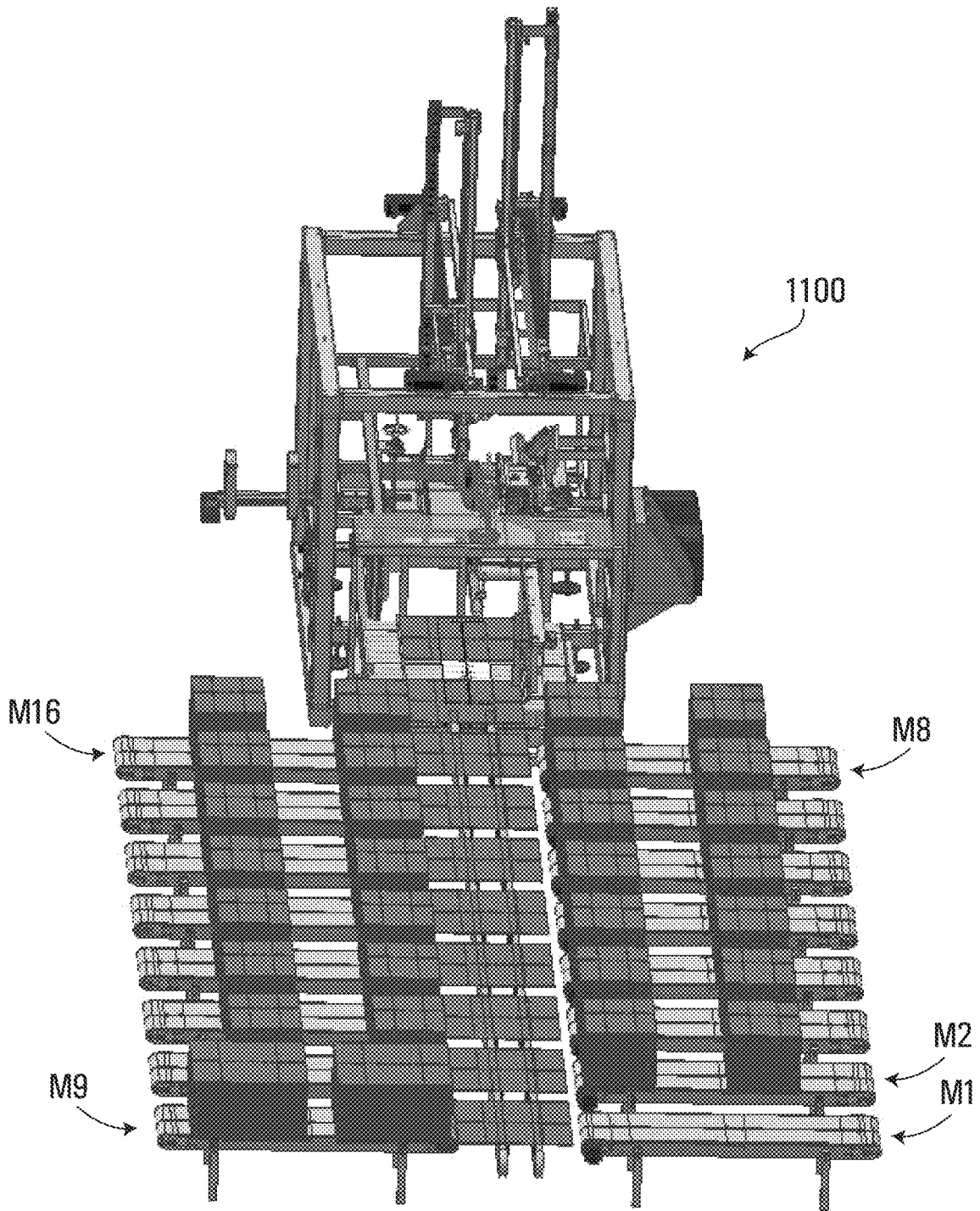

FIG. 56

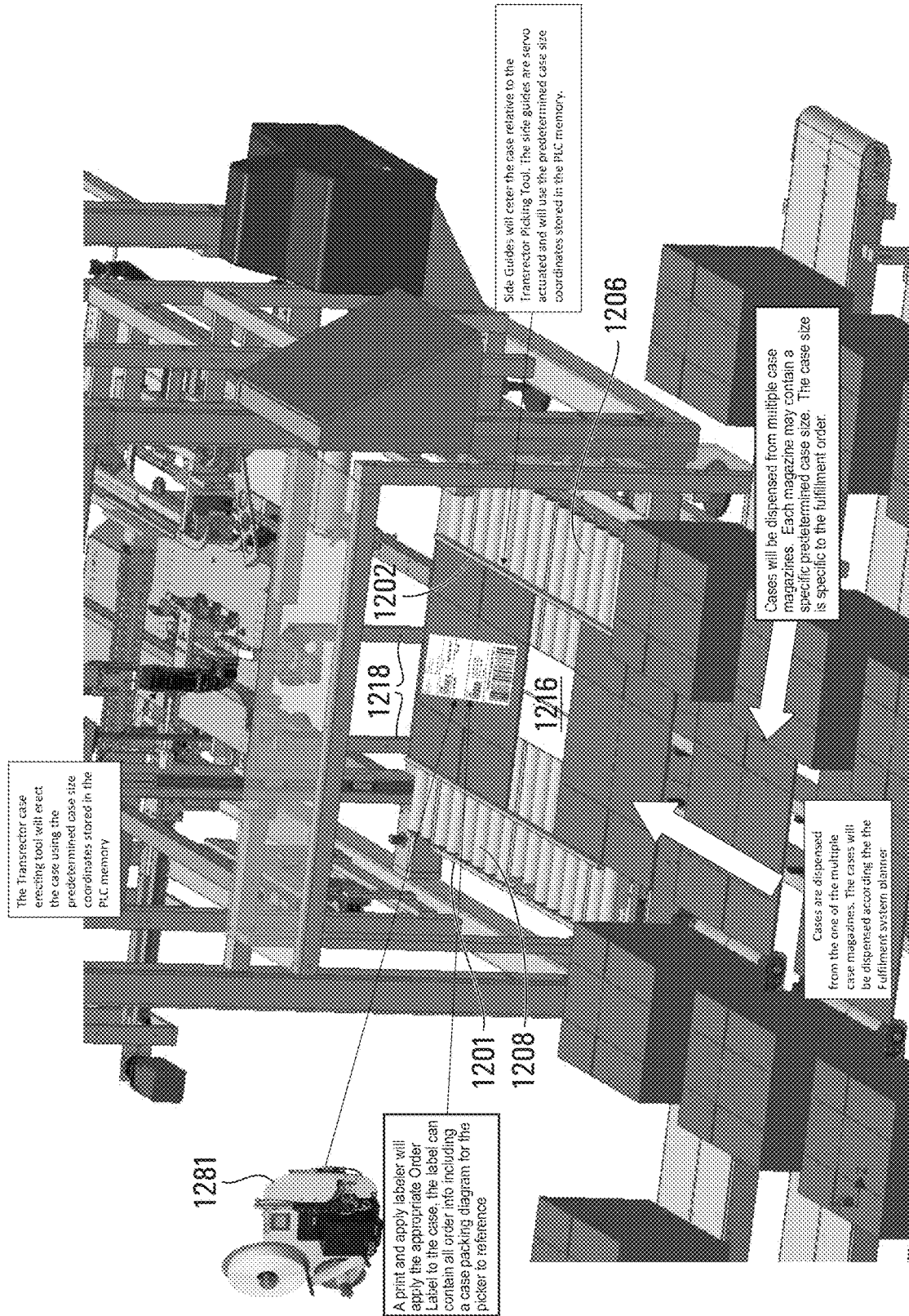

FIG. 57

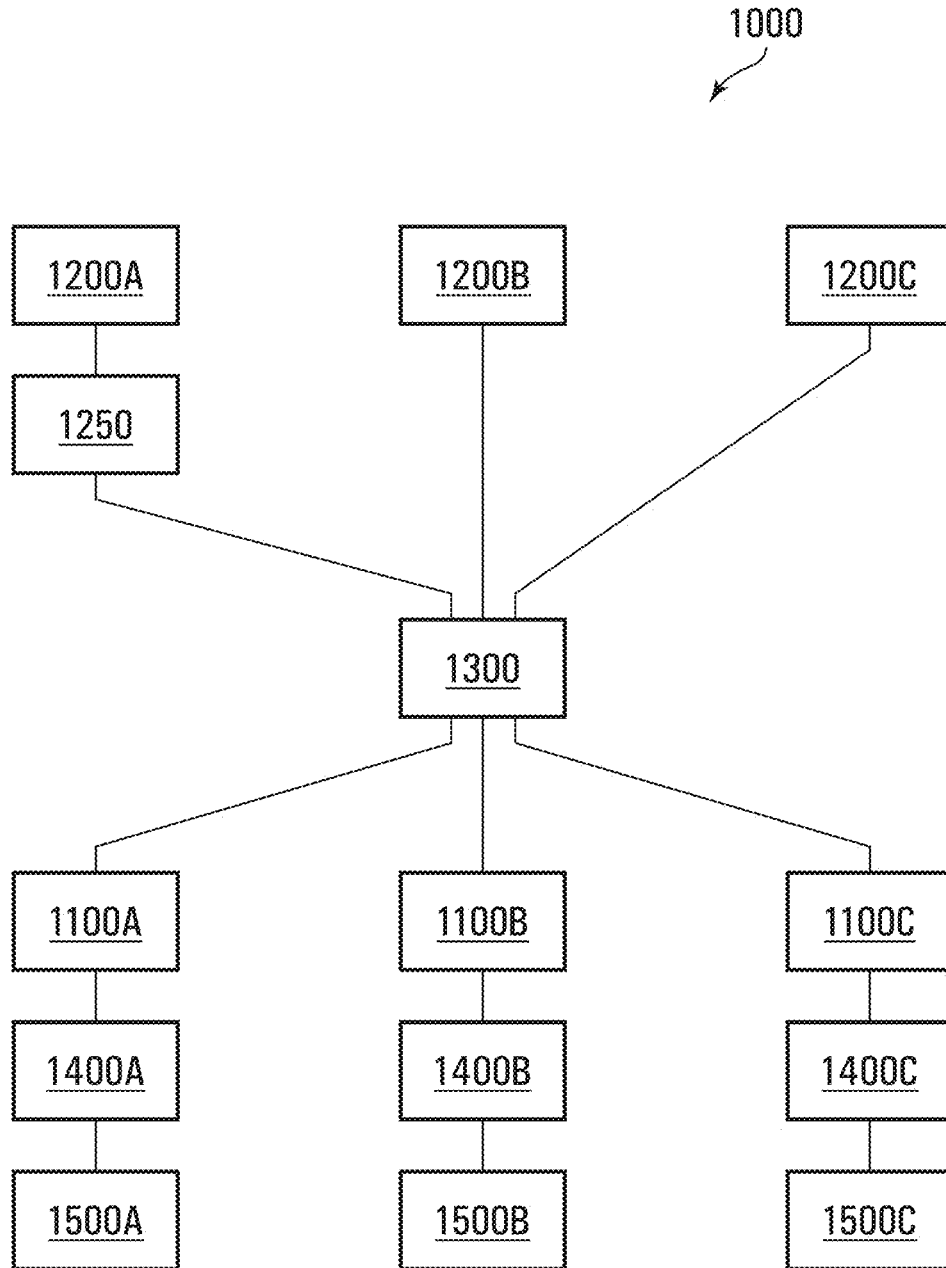



FIG. 58

From: Vendor Name Shipping Address City, State, Zip	To: Customer Name 123 Main St. New York, NY 10001
Ship to Postal Code 10001 	Carrier: Logistics, INC
PO: 985290 Qty: 15	
Store Number: 298 	For: Location: 298 123 Main St. New York, NY 10001
Serial Shipping Container 8347882 4890 438979 167 2 	

1283A

FIG. 59

From: Origin ID: #### Paul Reinhener 584 Elm Street Nashville, TN 18417	FedEx 	Ship Code: #### Account: S*****
Ship To: 412356-450 Bill Sender Chris Shiflett 37 East 14th St. New York, NY 10011		REF: Order 6541365  Delivery Address Bar Code
		Priority Overnight TRK# 4700 3402 8719 10011 NY-US TUE Deliver By: 14 FEB 06 XA KLLA 

1283B

FIG. 60

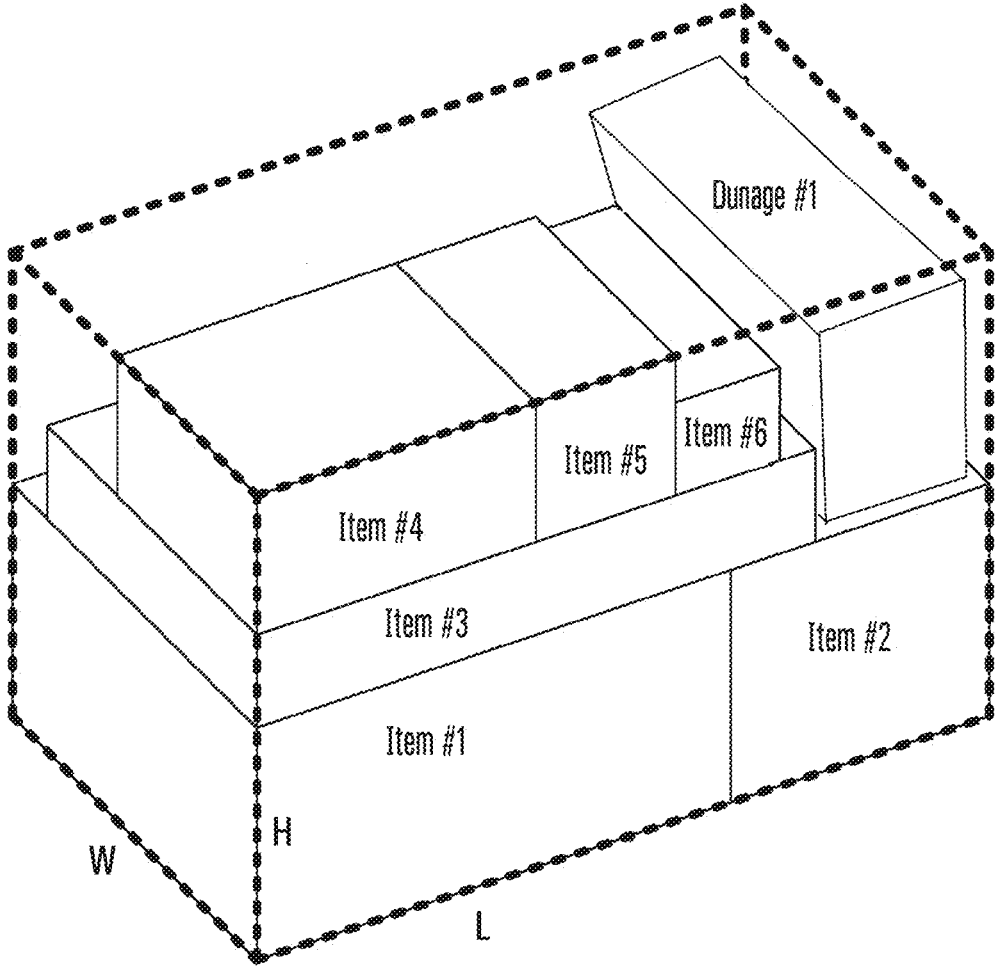

FIG. 61

Customer Order Fulfillment System

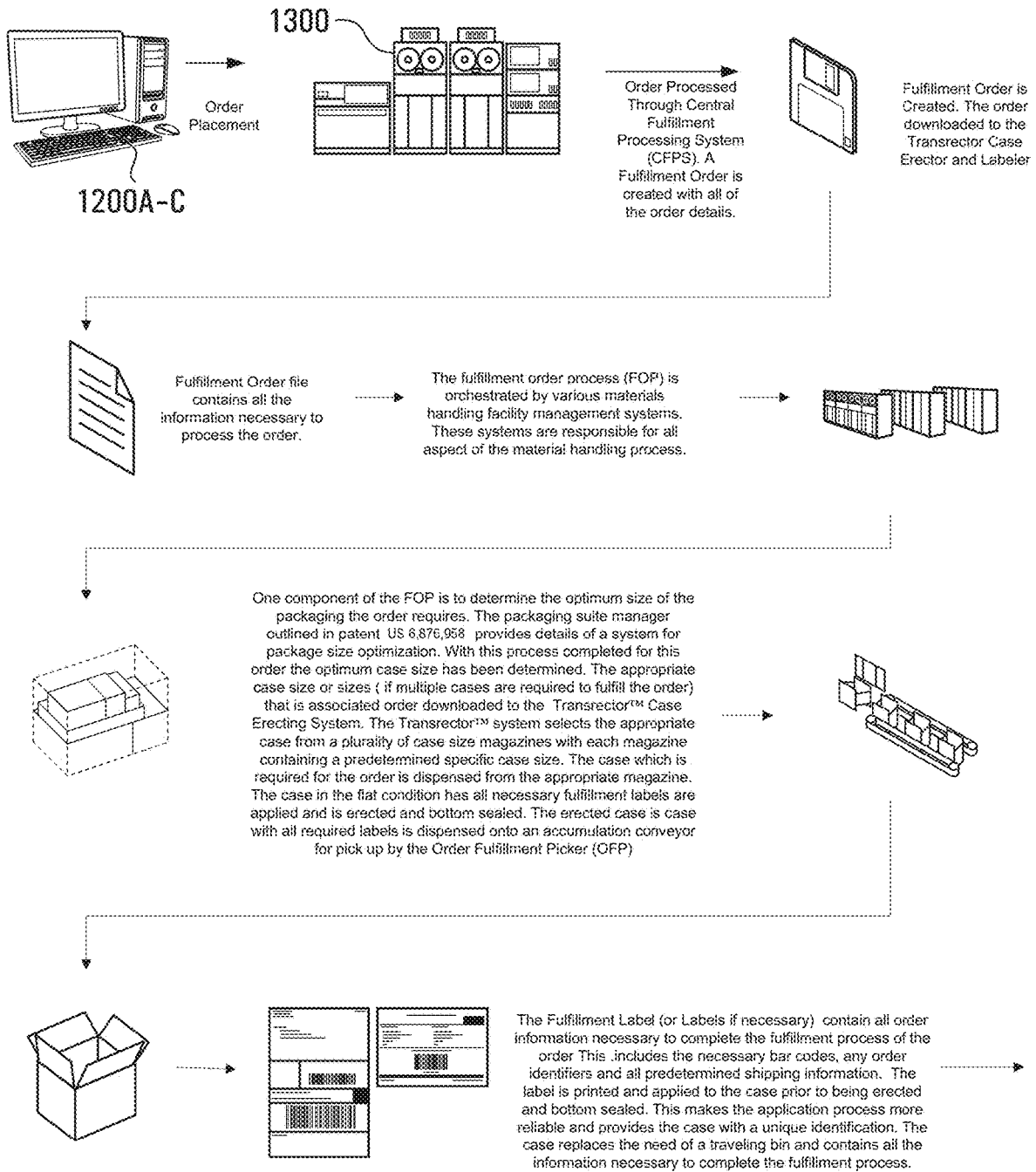
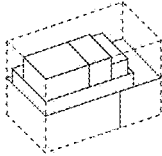
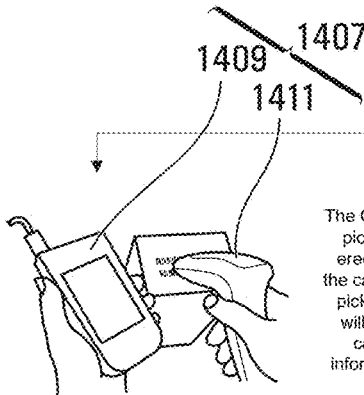
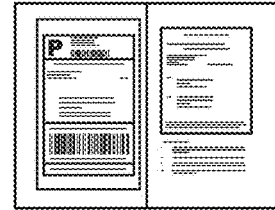

FIG. 62A

Customer Order Fulfillment System



The Fulfillment Label or Labels can also include other fulfillment information. For example a diagram of the order in which and how the ordered items are to be packed into the shipping case can be printed onto the label. The order in which the items are to be picked as determined by the FOP could also assist in optimizing the case packing operation by the OFPs.



The OFP will initiate the order picking process by picking an empty case from the Transrector™ erected case accumulation conveyor and place the case onto the OFP cart. Multiple cases can be picked and placed onto the OFP cart. The OFP will scan the appropriate bar code label on the case. This provides the OFP with all of the information necessary to pick and pack the order as predetermined by the CFPC.

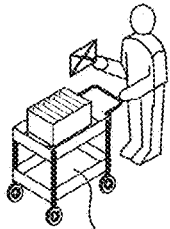

With all of the order information in the hands of the OFP the OFP picks and packs the order directly into the shipping case. The pick order and the pack pattern have been optimized by the CFPS using the Packaging Suite Manager. The OFP verifies that the right component are being packed into the case by bar code reading both the component and the case during the picking and packing operation. The Packaging Suite Manager also determines the necessary fill requirements and the OFP is directed to an appropriate fill station for the appropriate fill.

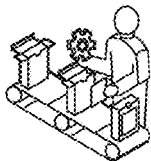
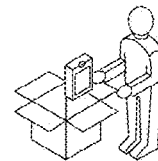

With the order completely picked the OFP places the fulfilled case with all components onto the predetermine Random Top Case Seal (RTCS) infeed conveyor. The RTCS reads the bar code and automatically adjusts the sealing components to close and seal the top of the case. The finished case is then conveyed into the central case distribution system for further sorting and processing.

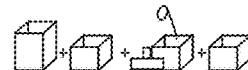

FIG. 62B

METHOD AND SYSTEM FOR ORDER FULFILMENT

CROSS-REFERENCE TO RELATED APPLICATIONS

This application is a continuation of U.S. patent application Ser. No. 14/644,842 filed on Mar. 11, 2015, which claims priority from U.S. Provisional Patent Application Ser. No. 61/951,263 filed on Mar. 11, 2014. The contents of the aforementioned applications are incorporated by reference herein.

This application also incorporates by reference herein International PCT Patent Application Serial No. PCT/CA2013/000245 filed on Mar. 15, 2013 and U.S. Provisional Patent Application Ser. No. 61/637,665 filed on Apr. 24, 2012, in their entireties.

FIELD OF THE INVENTION

The present invention relates generally to methods and systems for order fulfillment such as order fulfillment of products ordered by customers. It also relates to systems and methods for erecting cases from case blanks.

BACKGROUND

Containers are used to package many different kinds of products. One form of container used in the packaging industry is what is known generically as a "box" and it can be used to hold various products and sometimes other boxes containing products. Some in the packaging industry refer to boxes used to package one or more products as "cartons". Also in the industry there are containers/boxes that are known by some as "cases". In this patent document, including the claims, the words "case", "cases", "carton", "cartons", "container" and "containers" are used interchangeably to refer to boxes, cartons, trays and/or cases and the like that can be used to package any type of items including products and other cartons.

Cases come in many different configurations and are made from a wide variety of materials. However, many cases are foldable and are formed from a flattened state (commonly called a carton blank). Cases may be made from an assortment of foldable materials, including but not limited to cardboard, chipboard, paperboard, corrugated fibreboard, other types of corrugated materials, plastic materials, composite materials, and the like and possibly even combinations thereof.

Cases can be used to fulfil an order initiated by a customer for one or more products by obtaining each product from one or more locations in a storage facility such as a warehouse, loading the product(s) into a case, sealing the case, and then shipping the loaded case to a customer.

However, there are many obstacles to providing efficient methods and systems to fulfil customer orders, particularly where it is desirable to be able to fulfil orders for a large number of customers that may each have orders for a wide range of different kinds and/or number of products.

Accordingly, an improved method and system of product fulfillment is desirable.

SUMMARY

According to one aspect of the present invention there is provided a method of fulfilling an order, the order comprising at least one product, the method comprising: receiving

an order comprising at least one product; determining a suitable case from a plurality of available cases for holding the at least one product, the determining being a function of one or more characteristics of each the product of the at least one product and one or more characteristics of the plurality of available cases; forwarding information identifying the suitable case to a case former; providing a case blank corresponding to the suitable case to the case former; erecting a suitable case from the case blank corresponding to the suitable case with the case former; and prior to loading the suitable case with the at least one product, labelling the suitable case.

According to another aspect of the present invention there is provided a method of fulfilling an order, the order comprising a plurality of products, the method comprising: receiving an order comprising a plurality of products; determining a plurality of suitable cases from the plurality of available cases for holding the plurality of products, the determining being a function of at least one characteristic of each the product of the plurality of products and of at least one characteristic of the plurality of available cases; forwarding information identifying the plurality of suitable cases to at least one carton former; providing case blanks corresponding to each of the plurality of suitable cases to the at least one case former; the at least one carton former erecting the plurality of suitable cases from the case blanks corresponding to each of the plurality of suitable cases with the one or more case formers; prior to loading each of the suitable cases formed from the case blanks with the one or more case formers, labelling each of the suitable cases.

According to another aspect of the present invention there is provided a system for fulfilling an order, the order comprising at least one product, the at least one product having a product characteristic, the system comprising: an order fulfillment processor; a first case blank magazine and a second case blank magazine, the first and second case blank magazines each holding at least one case blank, with the at least one case blank in the first magazine and the second magazine each having a case blank characteristic; a carton former operable to erect a case from a case blank held in either of the first and second case blank magazines; a case blank feeding apparatus operable to selectively feed a case from each of the first case blank magazines to the case former; a labelling device operable to label a case blank prior to loading the case with at least one product; wherein the order fulfillment processor is operable to (a) receive an order comprising at least one product; (b) determine a suitable case for the at least one product from the at least one case in the first and second case blank magazines as a function of the product characteristic of each the at least one product and the case blank characteristic of each the at least one case blank in the first and second case blank magazines; and (c) forward information identifying the suitable case to a case former; and wherein the case former is operable to: (i) receive the information identifying the suitable case from the order fulfillment processor; (ii) select and receive a case blank from the case blank feeding apparatus for the suitable case from one of the first and second magazines; and (iii) erect the suitable case from the case blank; and wherein the labelling device is operable to label the case blank of the suitable case prior to or after the case former has erected the suitable case from the case blank.

According to another aspect of the present invention there is provided a system for fulfilling an order, the order comprising a plurality of products, the plurality of products each having a product characteristic, the system comprising: an order fulfillment processor; a plurality of case blank

magazines each holding a plurality of available case blanks, with the plurality of available case blanks in each of the plurality of magazines having a case blank characteristic; a carton former operable to erect a case from a case blank of each of the plurality of case blank magazines; a case blank feeding apparatus operable to selectively feed a case blank from each of the plurality of case blank magazines to the case former; a labelling device operable to label each of the cases prior to loading each case with at least one product; wherein the order fulfillment processor is operable to (a) receive an order comprising a plurality of products; (b) determine at least one suitable case for holding the plurality of products as a function of the product characteristic of the plurality of products and the case blank characteristics of each of the case blank in the plurality of case blank magazines; and (c) forward information identifying a suitable case to a case former; and wherein the case former is operable to: (i) receive the information identifying a suitable case from the order fulfillment processor; (ii) select and receive a case blank from the case blank feeding apparatus corresponding to the suitable case from one of the available case blanks in one of the plurality of case blank magazines; and (iii) erect the suitable case from the case blank; and wherein the labelling device is operable to label the case blank of the suitable case prior to or after the case former has erected the suitable case from the case blank.

According to another aspect of the present invention there is provided a system for forming a container from a tubular blank comprising a plurality of panels and flaps interconnected to provide a generally flattened tubular configuration, wherein the plurality of panels comprise a first panel, and a second panel interconnected to the first panel, the second panel being rotatable relative to the first panel, the system comprising: (a) a plurality of magazines, each of the plurality of magazines for storing a plurality of tubular blanks in a generally flat configuration; (b) a case blank transfer apparatus for transferring a case blank from a selected one of the plurality of magazines to an erector head; (c) an erector head operable to received a case blank at a pick up location from the case blank transfer apparatus and open the case blank; (d) a folding and sealing apparatus; and (e) a movement sub-system having at least one movement apparatus connected to the erector head for moving the erector head along a cyclical path extending between the pick up location and the folding and sealing apparatus.

According to another aspect of the present invention there is provided a method for forming a container from a tubular blank comprising a plurality of panels and flaps interconnected to provide a generally flattened tubular configuration, wherein the plurality of panels comprise a first panel, and a second panel interconnected to the first panel, the second panel being rotatable relative to the first panel, the method comprising: a. obtaining a selected case blank from one magazine of a plurality of magazines, each of the plurality of magazines storing a stack of tubular blanks in a generally flat configuration; b. transferring the selected case blank to an erector head; c. erecting the selected case blank with the erector head; and d. folding and sealing the selected case blank.

Other aspects and features of the present invention will become apparent to those of ordinary skill in the art upon review of the following description of specific embodiments of the invention in conjunction with the accompanying figures.

BRIEF DESCRIPTION OF THE DRAWINGS

In the figures which illustrate by way of example only, embodiments of the present invention,

FIG. 1A is top right front perspective view of part of a carton forming system in accordance with an example embodiment of the present invention;

FIG. 1B is a schematic flow chart of the power and control sub-system of the part of the case forming system of FIG. 1A;

FIG. 2 is a top right rear perspective view of the carton forming system of FIG. 1A;

FIG. 3 is a top right side perspective view of the carton forming system of FIG. 1A;

FIG. 4 is a front schematic elevation view of the carton forming system of FIG. 1A, but with several components omitted;

FIG. 5 is a rear schematic elevation view of the carton forming system of FIG. 1A but with several components omitted;

FIG. 6A is a top right perspective view of a magazine sub-system;

FIG. 6B is a top right perspective view of the magazine sub-system of FIG. 6A, but with several components omitted;

FIG. 6C is a right side elevation view of the magazine sub-system of FIG. 6A, but with several components omitted;

FIG. 6D is a top plan view of the magazine sub-system of FIG. 6A;

FIG. 7 is a right side perspective view of the system of FIG. 1A but with several components omitted to show the blank intake system and the two erector heads and movement apparatuses, and a folding and sealing apparatus;

FIG. 8 is a top right rear perspective view of the components of FIG. 7;

FIG. 9 is a top right front perspective view of the components of FIG. 7;

FIGS. 10A-10E are a plan, front and side elevation views and two perspective views, of a blank for a regular slotted case shown in a generally flattened tubular configuration;

FIGS. 11-16 are schematic right perspective sequential views of a blank of FIGS. 10A to 10E configured in an open configuration being sequentially processed into an erected carton;

FIGS. 17-25 and 27-29 are schematic right perspective views of system of FIG. 1A, but showing only a single movement apparatus, erector head and some parts of the folding and sealing apparatus, in various sequential stages of a blank of FIGS. 10A to 10E being processed into an erected carton;

FIG. 26 is a rear elevation view of the components of FIG. 17;

FIG. 26A is a schematic perspective view of part of the folding and sealing apparatus of system shown in FIG. 1A.

FIG. 30 shows a top right perspective view of a first embodiment of an erector head;

FIG. 31 is a side elevation view of the erector head of FIG. 30;

FIG. 32 is a bottom right perspective view of the erector head of FIG. 30;

FIG. 33 is a bottom plan view of the erector head of FIG. 30;

FIG. 34A is a top right perspective view of a second embodiment of an erector head;

FIG. 34B is a right side elevation view of the erector head of FIG. 34A;

FIGS. 35A, 35B and 35C show the erector head of FIG. 34A in various stages of opening a blank;

FIGS. 36-44 show the erector head of FIG. 34A and a sealing apparatus in various stages of erecting a blank and assembling it into a carton;

FIG. 45 is a schematic perspective view showing an alternative embodiment of a carton forming system; and in particular alternate erector heads, their corresponding moving apparatus and folding apparatus.

FIG. 46 is a plan view of a blank for a tray that may be processed according to some embodiments of the system.

FIG. 47 is a perspective view of a blank for an overwrapping regular slotted case (RSC) that may be processed according to some embodiments of the system.

FIG. 48 is a perspective view of a blank for an overwrapping regular slotted case (RSC) that may be processed according to some embodiments of the system.

FIG. 49 is a perspective view of an HSC case that may be formed according to some embodiments of the system.

FIGS. 50-52 are perspective views of an alternate folding and sealing apparatus that may be used in some embodiments of the invention.

FIG. 53 is a plan view of case former that is an alternate embodiment to the carton/case forming system of FIGS. 1 to 44 with some components of the case magazines omitted for clarity

FIG. 54 is a rear right side perspective view of the case former of FIG. 53.

FIG. 54A is an enlarged view of portion 54A in FIG. 54 with additional components illustrated.

FIG. 55 is a rear left side perspective view of the case former of FIG. 53.

FIG. 56 is rear perspective view of the case former of FIG. 53.

FIG. 57 is a rear perspective view of part of the case former of FIG. 53.

FIG. 58 is a schematic diagram illustrating an order fulfillment system.

FIG. 59 is a sample label that may be generated and used in the system of FIG. 58.

FIG. 60 is another sample label that may be generated and used in the system of FIG. 58.

FIG. 61 is a sample of a case packing diagram that may be generated and used in the system of FIG. 28.

FIGS. 62A and 62B together form a schematic representation of the operation of a system of FIG. 58.

DETAILED DESCRIPTION

With reference initially to FIGS. 1A-3, an example of a carton/case forming system that may be used as part of a product order fulfillment system is a carton/case forming system **100** (generally referred to as carton forming system **100**). Carton forming system **100** may include a frame generally referred to as frame **109**. The frame **109** may have integrated with it a series of panels **103** that may be made from a plastic or glass and that may or may not be transparent or semi-transparent. One or more of the panels **103** may be configured to operate as a hinged door so that interior portions of system **100** can be accessed. System **100** may also include a magazine **110** adapted to receive, hold and move a plurality of carton blanks **111** while in a substantially flat orientation. System **100** may include at least first and second erector heads **120a**, **120b** for retrieving carton blanks from the magazine **110**. Erector heads **120a**, **120b** may pick up the carton blanks **111** from the magazine **110** and then manipulate the blanks in such a way that, with the assistance of other components of system **100**, the carton blanks **111** are transformed into erected cartons.

The erector heads **120a**, **120b** may be moved by a movement sub-system. The movement sub-system may include one or more movement apparatuses. For example, erector head **120a** may be mounted to and moved by a first moving apparatus **115a**. Second erector head **120b** may be mounted to and moved by a second moving apparatus **115b**. In some embodiments only a single erector head and movement apparatus may be provided, but this may result in a lower production rate of erected cartons compared to when particularly two or possibly more, movement apparatuses and erector heads are provided, as illustrated in the drawings.

System **100** may also include a folding and sealing apparatus generally designated **130**, which may be configured to fold one or more flaps of each carton blank and provide for sealing of one or more flaps as part of the process in forming fully erected cartons. In co-operation with erector heads **120a**, **120b**, a common folding and sealing apparatus **130** may be configured to handle in alternating sequence, carton blanks **111** carried by both erector head **120a** and erector head **120b**. System **100** may also include a carton discharge conveyor **117** for receiving and moving away carton blanks **111** once they have been fully erected.

The structural/mechanical components of system **100** may be made from any suitable materials. For example, frame members, and many of the parts that make up the erector heads **120**, moving apparatuses **115**, many of the components and parts that make up folding and sealing apparatus **130**, and magazine **110**, may be made of steel or aluminium, or any other suitable materials. Aluminum is particularly suitable for most parts. However, plates that hold the suction cups on the erector head and flanges that mount on gearbox shafts can be made from stainless steel for strength and hardness. Parts and components may be attached together in conventional ways such as for example by bolts, screws, welding and the like.

An example of a scheme for the power and data/communication configuration for system **100** is illustrated in FIG. 1b. The operation of the components of carton forming system **100**, and of system **100** as a whole, may be controlled by a programmable logic controller ("PLC") **132**. PLC **132** may be accessed by a human operator through a Human Machine Interface (HMI) module **133** secured to frame **109**. HMI module **133** may be in electronic communication with PLC **132**. PLC **132** may be any suitable PLC and may for example include a unit chosen from the Logix 5000 series devices made by Allen-Bradley/Rockwell Automation, such as the ControlLogix 5561 device. HMI module **132** may be a Panelview part number 2711P-T15C4D1 module also made by Allen-Bradley/Rockwell Automation. It should be noted that not all of the sensors, motors, servo motors, drives, vacuums, vacuum generators and vacuum cups described hereinafter are specifically identified in FIG. 1B.

Electrical power can be supplied to PLC **132**/HMI **133**, and to all the various servo motors and DC motors that are described further herein. Compressed/pressurized air can also be supplied to the vacuum generators and pneumatic actuators through valve devices such as solenoid valves that are controlled by PLC **132**, all as described further herein. Servo motors may be connected to and in communication with servo drives that are in communication with and controlled by PLC **132**. Similarly, DC motors may be connected to DC motor drives that are in communication with and controlled by PLC **132**; again all as described further herein. Additionally, various other sensors are in communication with PLC **132** and may (although not shown) also be supplied with electrical power.

With reference now to FIGS. 10A-10E and 11A, an example of one kind of tubular carton blank 111 that can be processed by system 100 to form a regular slotted case (RSC) is disclosed. Other kinds of carton blanks, tubular carton blanks, and tubular carton blanks of different sizes can be processed by system 100.

Each carton blank 111 may be generally initially formed and provided in a flattened tubular configuration as shown in FIGS. 10A-10E. Each blank 111 has a height dimension "H"; a length dimension "L"; and a major panel length "Q" (see FIG. 10B). By inputting each of these three dimensions for a blank 111 to be processed by system 100, into PLC 132, PLC 132 can determine if the system 100 can process that size blank without the necessity for manual intervention to make an adjustment to one or more components of the system 100. If PLC 132 determines that the adjustment can be made without human intervention, the PLC 132 may make the necessary adjustments to positions and/or movements of at least some of the components forming system 100, including the path of movement of erector heads 120a, 120b as the erector heads move and cycle through their processing sequences.

However, in some systems 100, for some size blanks 111, PLC 132 may determine that human intervention of some kind is necessary to make set-up adjustments to the positioning/orientations of at least some of the components of the system to enable the system to process the blank and may accordingly inform an operator of system 100.

Blank 111 may have opposed major panels A and C integrally interconnected to a pair of opposed minor panels B and D to form a generally cuboid shaped blank when opened. An overlap strip of carton blank material may be provided between panel B and panel A that can be sealed by conventional means such as a suitable adhesive, to provide an overlapping seam joint in the vicinity of "P" (see FIG. 10A). This overlap may join the panels A, B, C and D into a continuous blank that is of generally flattened tubular configuration as shown in FIG. 10A. A number of such blanks 111, in a flattened configuration, can be delivered to the vicinity of system 100 that can be erected into the generally open tubular configuration shown for example in FIG. 11.

Also, as shown in FIGS. 10A-10E and 11, are upper side major and minor flaps E, H, L, I that are provided one side of the respective major and minor panels A-D. A second set of major and minor flaps F, G, K and J are also provided on the opposite, lower/bottom sides of the major and minor panels A-D. However, in other embodiments, cartons having other side panel configurations can be formed. The panels and flaps can be connected to adjacent flaps and/or panels by predetermined fold/crease lines (shown in broken lines). These fold/crease lines may for example be formed by a weakened area of material and/or the formation of a crease with a crease forming apparatus. The effect of the fold lines is such that one panel such as for example panel A can be rotated relative to an adjacent panel such as D or B along the fold lines. Flaps may also fold and rotate about fold lines that connect them to their respective panels.

As shown in FIG. 11, blank 111 may be designated with a first datum line "W1" that passes through the mid-point of the fold line between panel D and flap K, and the mid-point of the fold line between panel B and flap J. This datum line W1 may be determined by PLC 132 for a particular blank or group of blanks 111 to be processed, based on the input of the dimensions H, L and Q of the blanks. Blank 111 may be designated with a second datum line "W2" that may be determined by PLC 132 and which passes along and is

generally parallel to the fold line between panel D and flap K, and the mid-point of the fold line between panel A and flap F. Datum W1 will be parallel to Datum W2. PLC 132 may also determine the relative position of the bottom of the erected carton as this will be aligned with a vertical datum plane passing through Datum W1 and Datum W2. Aligning the position datum W2 and of the datum plane with other components in system 100 will ensure that the carton is properly positioned during processing through system 100. Also, the vertical distance R between datum W1 and the datum line W2 may be calculated by PLC 132. This can ensure that PLC 132 knows where it needs to position the erector head so that top panel A, and accordingly, datum W1 are properly positioned throughout the processing of the blank by system 100.

System 100 is able to track and modify the position of the blank 111, and in particular the vertical position of the datum line W1 of the blank as the blank moves longitudinally through system 100 and as various components of system 100 engage the blank 111 during its movements. This will ensure that the blank 111 being processed is appropriately positioned relative to the system components so that the system components engage the blank at the correct position on the blank during processing of the blank.

As will be described hereinafter, carton blank 111 may be transformed from a generally flattened tubular configuration to an open tubular configuration and the flaps may be folded and sealed to form the desired erected carton configuration. The carton may be configured as a top opening carton suitable to be delivered to a carton loading conveyor with an upwardly facing opening or with a sideways facing opening suitable for side loading.

Carton blanks 111 may have flaps that provides material that can, in conjunction with a connection mechanism (such as for example with application of an adhesive, sealing tape or a mechanical connection such as is provided in so-called "Klick-lok™" carton blanks) interconnect flap surfaces, to join or otherwise interconnect, flaps to adjacent flaps (or in some embodiments flaps to panels), to hold the carton in its desired erected configuration.

Carton blanks 111 may be made of any suitable material (s) configured and adapted to permit the required folding/bending/displacement of the material to reach the desired configuration. Examples of suitable materials are chipboard, cardboard or creased corrugated fiber-board. It should be noted that the blank may be formed of a material which itself is rigid or semi-rigid, and not per se easily foldable but which is divided into separate panels and flaps separated by creases or hinge type mechanisms so that the carton can be erected and formed.

Turning now to the components of system 100, various specific constructions of a suitable magazine 110 might be employed in system 100. With particular reference now to FIG. 3, FIGS. 6a-d, and FIG. 7, magazine 110 may be configured to hold a plurality of carton blanks 111 in a vertically stacked, flattened configuration, and be operable to move the stack of carton blanks 111 longitudinally in a direction generally parallel to longitudinal axis Y under the control of PLC 132, to a pick up position where an erector head 120a and 120b can retrieve cartons from the magazine.

Magazine 110 may comprise a single conveyor or other blank feed apparatus to deliver blanks to a pick up location. In the illustrated embodiment of FIGS. 1A to 9, two conveyors are disclosed: an in-feed conveyor 204; and an alignment conveyor 206. However, as will described hereinafter in other embodiments, the blank feed apparatus may be configured with multiple in-feed conveyors feeding car-

tons/cases from multiple magazines that hold carton/case blanks having different configurations. This enables a system **100** to by automation, selectively and sequentially erect cartons that differ in size, type, and/or configuration from each other.

Returning to system **100** of FIGS. **1A** to **9**, in-feed conveyor **204** may be configured and operable to move a stack of blanks **111** from a stack input position (where a stack may be loaded onto conveyor **204** such as by human or robotic placement) to a position where the stack of blanks is transferred to horizontally and transversely aligned, alignment conveyor **206**. Alignment conveyor **206** may be positioned longitudinally downstream in relation to in-feed conveyor **204** and be used to move the stack of blanks to the pick up position. Magazine **110** may be loaded with, and initially hold, a large number of carton blanks **111** in a vertical stack, with the stack resting on in-feed conveyor **204**. A rear wall **212** mounted to a lower portion of a magazine frame generally designated **202**, can be configured to retain the one or more stacks from falling backwards when initially loaded on conveyor **204**. Rear wall **212** may have a generally planar, vertically and transversely oriented surface facing the stack of blanks **111**. Rear wall **212** and conveyor **204** may be of an appropriate length to be able to store a satisfactory number of stacks of blanks in series on conveyor **204**. PLC **132** can control the operation of conveyor **204** to move one stack at a time to the alignment conveyor **206**.

In feed-conveyor may have one or more stacks of blanks arranged longitudinally on a conveyor belt **214** so that they can in turn be fed onto alignment conveyor **206**. A sensor may be provided in the vicinity of conveyor **204** to monitor the number of stacks waiting on conveyor **204** and that sensor may be operable to send a warning signal to PLC **132** that can alert an operator that the magazine is low and needs to be replenished (e.g. because the stack on the alignment conveyor being processed by erector head **120** is the only one left). The sensor may be a part number 42GRP-9000-QD made by Allen Bradley.

Of particular note, a plurality of stacks of blanks might be provided on conveyor **204**. Each stack may be included with some kind of information indicator that can be read by an information reader such as electronic or an optical reading device. For example, a bar code may be provided on a stack of blanks such as on the top or bottom blank of the stack. The bar code may be read by a suitably positioned bar code reader. The bar code reader may be in communication with PLC **132**. The bar code may provide information indicative of a characteristic of the blanks in the stack. For example, the bar code may identify the size and/or type of blank in a particular stack. Other information indicators may be used such as for example RFID tags/chips and RFID readers. The information can then be automatically provided by the information reader to PLC **132** which can determine whether the current configuration of system **100** can handle the processing the particular type/size of blanks without having to make manual adjustments to any of the components. It is contemplated that within a certain range of types/sizes of blanks, system **100** may be able to handle the processing of different types/sizes of blanks without manual adjustment of any components of system **100**. The bar code/RFID tag may provide the information about the dimensions of the blank as discussed above and then PLC **132** can determine adjustments, if any that need to be made to (a) the erector device operation; (b) the magazine and the tampering apparatuses in the magazine; (c) to provide a suitable path for the movement of the movement sub-system to provide for

suitable pick up of a blank from the magazine and suitable handling by the erector device and the folding and sealing apparatus; and (d) adjustment of at least some of the components of the folding and sealing apparatus to be able to process a particular blank or a particular stack of blanks. The result is that system **100** may be able to process automatically, at least some different types/sizes/configurations of blanks to form different cartons, without having to make manual operator adjustments to any components of system **100**.

Conveyor **204** may include a series of transversely and horizontally oriented rollers **210** mounted to the lower portion of a magazine frame **202** for free rotation. Rollers **210** may allow for generally horizontal longitudinal downstream movement of the stack towards conveyor **206**. A conveyor belt **214** may be provided that may be driven by a suitable motor such as a DC motor or a variable frequency drive motor **291** (see FIG. **1b**). Motor **291** may be DC motor and may be controlled through a DC motor drive (all sold by Oriental under model AXH-5100-KC-30) by PLC **132**.

Conveyor belt **214** may have an upper belt portion supported on the rollers **210**. Once PLC **132** is given an instruction (such as by a human operator through HMI module **133**), upper belt portion of belt **214** may move longitudinally downstream towards conveyor **206**. In this way belt **214** can move a stack of blanks **111** longitudinally downstream, with the stack of blanks at its outer transverse portions also being supported on the rollers **210**. PLC **132** can control motor **291** through the motor drive and thus conveyor **204** can be operated to move and transfer the stack towards and for transfer to the alignment conveyor **206**.

Stack alignment conveyor **206** may also include a series of transversely oriented rollers **208** that are mounted for free rotating movement to a lower portion of the magazine frame **202**. A conveyor belt **216** may be driven by a motor **292** that may be like motor **291** and with a corresponding motor drive. Motor **292** may also be controlled by PLC **132**. Belt **216** may be provided with an upper belt portion supported on rollers **208** and upon which the stack of blanks **111** may be supported. Conveyor belt **214** may be operated to move the stack of blanks **111** further longitudinally until the front face of the stack abuts with a generally planar, vertically and transversely oriented inward facing surface of front end wall **218**.

Conveyor belt **214** of conveyor **204** and conveyor belt **216** of conveyor **206** may be made from any suitable material such as for example Ropanyl.

A sensor **242**, such as an electronic eye model 42KL-D1LB-F4 made by ALLEN BRADLEY, may be located within the horizontal gap between belt **214** and belt **216**. Sensor **242** may be positioned and operable to detect the presence of the front edge of a stack of blanks as the stack of blanks begins to move over the gap between conveyor belt **214** and conveyor belt **216**. Upon detecting the front edge, sensor **242** may send a digital signal to PLC **132** (see FIG. **1b**) signalling that a stack has moved to a position where conveyor **206** can start to move. PLC **132** can then cause the motor **292** for conveyor **206** to be activated such that the top portion of belt **216** starts to move the stack downstream. In this way, there can be a "hand-off" of the stack of blanks from in-feed conveyor **204** to alignment conveyor **206**.

Once the rear edge of the stack of blanks **111** has passed the sensor **242** a signal may be sent to PLC **132** (see FIG. **1b**) which can then respond by sending a signal to shut down the motor **291** driving belt **214** of conveyor **204**. Conveyor **204** is then in a condition ready to be loaded with another stack

of blanks **111**. Meanwhile conveyor **216** can continue to operate as it moves the stack of blanks **111** to the pick up position.

The presence of a stack of blanks **111** at the pick up location may be detected by a sensor **240** that may be the same type of sensor as sensor **242**. The sensor **240** may detect the presence of the front edge of a stack of blanks at the pick up position and may send a digital signal to PLC **132** signalling that a stack is at the pick up position. At the pick up position, the stack of blanks may be “squared up” and thereafter, once properly aligned, single carton blanks **111** may be retrieved in series from the stack of blanks **111** by the alternate engagement of the erector heads **120a**, **120b** with the upper most blank in the stack.

The magazine **110** may be configured and operable to enable the stack of blanks **111** to be properly positioned and oriented in a pick up position for proper engagement by one of the erector heads **120a**, **120b**. During movement of the stack of blanks **111** longitudinally by conveyors **204** and **206**, the left hand side of the stack of blanks may be supported and guided by a left hand side wall **200**. Side wall **200** may be mounted to a lower portion of lower frame **202** and side wall **200** may be oriented generally vertically and may extend longitudinally for substantially the full lengths of conveyors **204** and **206**.

The right hand side of the magazine **110** adjacent conveyor **204** may be left generally open; however to the right hand side of conveyor **206** there may be a right hand side guide wall **201**.

Possible mounting arrangements for side walls **200** and **201** are illustrated in further detail in FIGS. 6A-6D. In this regard, lower frame portion **202** may include bottom support plates **251**, **255**, **259** and **263** that are supported on the ground terrain/floor with these plates being spaced from each other and oriented in a generally transverse, parallel relationship to each other. Each of support plates **251**, **255**, **259** and **263** has mounted to an upper surface thereof, one of the tracks **253**, **257**, **261** and **265**. Side wall **200** may be supported by connector blocks **267** that fit onto and are capable of sliding laterally on and in relation to tracks **253** and **261**. Similarly side wall **201** may be supported by connector blocks **269** that fit onto and are capable of sliding laterally on and in relation to tracks **255** and **263**.

A drive mechanism may be provided to drive each of side walls **200** and **201** on their respective tracks. For side wall **200**, a drive mechanism that is in electronic communication with PLC **132** can be provided. By way of example, a servo motor **258** with gear head may be provided and be in electronic communication with PLC **132** through a servo drive (as per FIG. 1b). Examples that could be used are servo motor MPL-B1530U-VJ42AA made by ALLEN BRADLEY, in combination with servo drive 2094-BC01-MP5-S also made by ALLEN BRADLEY and gear head AE050-010 FOR MPL-A1520 made by Apex.

A lead screw rod **262** may be inter-connected to servo motor/gear head **258**. Lead screw rod **262** may pass through a nut such as a brass nut **264**. Nut may be fixedly secured to a plate **293**. Plate **293** may be interconnected to spaced, generally vertically oriented bar members **294**. Bar members **294** may be interconnected to support frame (not shown) forming part of side wall **200**. By activating servo motor/gear head **258**, the rotation of the servo may rotate the screw rod **262**. As rod **262** passes through nut **264**, the nut is moved laterally either inwards or outwards, thereby causing wall **200** to slide on tracks **252**, **261** inwards or outwards depending upon the direction of rotation of screw rod **262**. An encoder may be provided within or in association with servo

drive motor **258** and the encoder may rotate in relation to the rotation of the respective drive shaft of the servo drive. The encoder may be in communication with, and provide signals to the servo drive which can then pass on the information to PLC **132**. Thus, PLC **132** may be able to determine the longitudinal position of the screw rod **262** in real time and thus the transverse position of side wall **200** and can operate the servo drive **258** to adjust the position of the side wall **200**. The particular type of encoder that may be used is known as an “absolute” encoder. Thus once the encoder is calibrated so that a position of the screw rod **262** is “zeroed”, then even if power is lost to system **100**, the encoder can maintain its zero position calibration. However, as side wall **200** is not moved during processing of a blank **111**, the mechanism for adjusting the transverse position of side wall **200** may alternatively be a simple hand crank mechanism instead of a servo drive motor in communication with PLC **132**. It should be noted that a proper position for left side wall **200** during the processing of a blank stack is that shown in FIG. 7, with the wall **200** in abutment with the left side edges of the blanks in each stack. The proper positioning of wall **200** will ensure that the datum line W1 when the blanks are flattened is properly transversely aligned to be picked up by erector heads **120a**, **120b** and moved through folding and sealing apparatus **130**, as described hereinafter in detail to achieve proper folding and sealing of the carton blank.

Similarly, for side wall **201**, a drive mechanism **260** (that may be the same types of components that used for side wall **200**) that is also in electronic communication with PLC **132** may be provided. By way of example, a servo motor with gear head designated **260** may be provided and also be in electronic communication through a servo drive with PLC **132**. A lead screw rod **266** may be inter-connected to servo motor/gear head **266** (which may be like servo/gear head **268**). Lead screw rod **266** may pass through a nut such as a brass nut (not visible in Figures) like nut **264**. The nut may be fixedly secured to a plate **295**. Plate **295** may be interconnected to spaced, generally vertically oriented bar members **296**. Bar members **296** may be interconnected to side wall support frame generally designated **271** (see FIG. 6c) that forms part of side wall **201**. By activating servo motor/gear head **260**, the rotation of the servo may rotate the screw rod **266**. As rod **266** passes through the nut, the nut is moved laterally either inwards or outwards, thereby causing wall **201** to slide on tracks **257**, **265**. An encoder may be provided within or in association with servo drive motor **260** and the encoder may rotate in relation to the rotation of the respective drive shaft of the servo motor. The encoder may be in communication with a servo drive and thus provide signals to PLC **132**. Thus, PLC **132** may be able in real time to determine the longitudinal position of the screw rod **266** and thus the transverse position of side wall **201**. Thus PLC **132** can operate the servo motor **260** to adjust the position of the side wall **201**. An “absolute” encoder may also be used in this application.

During operation of system **100** in erecting a carton, side wall **200** may remain stationary, but side wall **201** may be moved laterally as part of the blank stack alignment procedure to provide for generally longitudinal alignment of the side edges of blanks **111** in the stack as they are held between side walls **200** and **201**.

A lateral tampering apparatus may be secured to side wall **201** and may be used to affect lateral alignment of the front and rear side edges of the blanks **111** in the stack (i.e. the front and rear edges of the blanks in the stack are generally aligned with a vertical axis such as axis Z in FIG. 7). A lateral tampering apparatus generally designated **275** may

include a horizontally and longitudinally oriented support plate **270** that may be attached at either end to vertical members of side wall support frame **271**. Attached to an outer surface of plate **270** may be a track **272**. Secured to track **272** for sliding longitudinal movement along track **272** may be a slider block **273**. Attached to slider block **273** may be a pair of upstanding support plates which at their upper ends are secured to a double acting, pneumatic actuator **276** such as the model DFM-25-80-P-A-KF Part #170927 made by Festo. Actuator **276** may have one or more piston arms (not visible in FIG. *6b* or *6c* because they are shown retracted). Piston arms of actuator **276** may reciprocate between retracted and extended positions—back and forwards in a longitudinal direction. With reference to FIG. *1b*, a pneumatic actuator may be supplied with pressurized air communicated through electronic solenoid valves for causing the piston arms to retract and extend. The solenoid valves may be a model CPE14-M1Bh-5J-1/8 made by Festo and may be controlled by PLC **132**. Alternatively, a linear servo drive system—similar to one described in connection with the movement of side walls **200** and **201**—may be provided for this actuator. Such a servo drive system could be controlled by PLC **132**. PLC **132** could make adjustments to the movement of both side walls **200** and **201** as well as this actuator for the lateral tampering apparatus, such that magazine **110** could be automatically adjusted to process a wide range of sizes of blanks.

It should be noted that during the operation of system **100** in erecting cartons, the slider block **273** will not move along track **272**. Slider block **273**, and the components attached directly or indirectly thereto including actuator **276**, will not move longitudinally during operation. However the longitudinal position of slider block **273** can be adjusted during the set-up of system **100** when processing particular sizes of carton blanks.

Attached to the end of the piston arms of actuator **276** may be a transverse plate **278** that may pass through a longitudinally extending slot **279** through side wall **201**. The distal end of plate **278** from piston arms is attached to a vertical tamper plate **280** that is positioned transversely inwards from the inner surface of side wall **201**. Retraction of the piston arms of actuator **276** can cause plate **278** to engage the rear side edges of the blanks **111** in the stack and as the front edges of those blanks are pushed up against the inner surface of the front wall **218**, the front and rear edges of the blanks can be laterally aligned. While a pneumatic actuator **276** is illustrated, other alignment devices could be used. For example, a linear servo drive in communication with PLC **132** might be employed, that would perform the same function but it could electronically position the vertical tampering plate **280**, and the operator may not have to adjust it manually during system set up.

By operation of PLC **132**, suitable adjustment of right side wall **201** and tamper plate **280**, the blanks **111** can be moved to precisely the known pick up location and their orientation may be “squared-up” blanks **111** in a stack of blanks that is held against front wall **218**, and may thus ensure that the blanks **111** are in the proper location for being engaged by the erector heads **120a**, **120b**.

In particular, once the stack of blanks **111** have generally reached the pick up location, PLC **132** can send a signal to drive mechanism **260** to cause the drive mechanism **260** to cause side wall **201** to move laterally inwards towards the side of stack of blanks **111**. PLC **132** will cause the drive mechanism **260** to move a sufficient distance to cause the edges of the blanks **111** to become in contact along their length with inner surface of longitudinally aligned inner

surface of side wall **201**. However, PLC **132** will not cause side wall **201** to be moved to such an extent that it creates a force on the stack of blanks such that causes the blanks to buckle/be damaged if they are compressed to a significant extent between side walls **200** and **201**. PLC **132** may be able to determine how much to move side wall **201** towards side wall **200** by virtue of the carton size dimensions that have been inputted into the PLC, including dimension H (see FIG. *10A*). The amount of slight compression can be fine tuned such as by trial and error for different sized carton. It should be noted that for many sized cartons, the manufacturers comply with industry standard carton sizes.

Once the longitudinal alignment has been completed by side wall **201**, PLC **132** can cause actuator **276** to be activated to cause the vertical plate **280** to engage the rear edges of the blanks **111** in the stack. PLC **132** may cause the drive mechanism **260** to move a sufficient distance to cause the rear edges of the blanks **111** to come in contact along their length with inner surface of laterally aligned inner surface of plate **280**. However, the amount of retraction of the piston arms will not cause side wall vertical plate **280** to be moved to such an extent that it creates a force on the stack of blanks that would cause the blanks to buckle/be damaged if they are compressed too much between plate **280** and front wall **218**. The appropriate manual positioning and securement (such as by tightening screws appropriately positioned through block **273**, can secure actuator **276** at an appropriate longitudinal position on rail **270**.

Thus, by way of review: The tampering actuator **276** may ride on the side guide wall **200**. For a carton of a particular size/shape, the tampering actuator **276** can be adjusted manually in a fore-aft direction so that when the actuator **276** is retracted, the vertical tamper bar **280** is in the right position to push the blanks up against the front wall **218** (without squeezing them).

The sliding assembly of components that includes actuator **276** may also have a pointer or indicator, and on the stationary part of the magazine there may be a numeric scale to assist in rapidly manually adjusting the actuator to the correct position on rail **270** for a known case size.

In review the tampering sequence for ensuring the blanks are properly squared up at the pick up location steps include the following:

1. The right-hand-side magazine side guide wall **201** under control of PLC **132** expands wide enough to allow the stack of blanks to enter on alignment conveyor **206**, even if the stack is misaligned and/or the blanks in the stack are not perfectly square with each other and in relation to the X-Y axes.

2. The belt **216** advances the stack of blanks **111** towards the front stop datum and may abut with front wall **218**

3. The tampering actuator **276** is extended, and then the side guide wall **201** may contract to make contact with the side of the case stack and press the side wall **201** against the left hand side guide wall **200**. This aligns the cases so the side edges of blanks are aligned with each other and the longitudinal side wall of the walls **200** and **201**.

4. The tampering actuator **276** may retract, and the tampering bar **280** presses the stack forward, thereby aligning the blanks in the stack so that their front and rear edges are vertically aligned with each other and with the inner face of the bar **280** and the inside surface of front wall **218**

5. The blanks are then properly positioned so that the erector heads can begin picking up blanks from the stack.

Turning now to other components of system **100**, to retrieve blanks from the magazine **110**, at least a first engagement device may be provided to engage a panel of a

blank **111** and thus be able to hold and move the blank. Where the blank is a tubular blank, system **100** may be provided with a first engagement device for engaging one panel (e.g. Panel A) of a blank and a second engagement device for engaging a second panel (e.g. Panel B) of the blank. **111**. The first and second engagement devices may comprise one or more suction cups providing a suction force onto a panel acting generally normal to the surface of the panel that is engaged, as described further below. Other types of suitable engagement devices might be employed. The first and second engagement devices may be rotatable relative to each other so that the first panel can be rotated relative to the second panel. The first and second engagement devices may be mounted to a single common erector head.

With reference to FIG. 7, system **100** may be provided with a movement sub-system that may be a pair of movement apparatuses each supporting and moving one of erector heads **120a**, **120b**. Each erector head **120a**, **120b** may have a dedicated, independently driven and controlled movement apparatus **115a**, **115b**. Thus erector head **120a** may be supported and moved by movement apparatus **115a**. Similarly erector head **120b** may be supported and moved by movement apparatus **115b**. Movement apparatus **115a** may be constructed in a manner that is substantially identical to movement apparatus **115b** but may be configured as mirror image of movement apparatus **115b**. In this way, movement apparatus **115a** may support erector head **120a** from a right hand side and movement apparatus **115b** may support erector head **120b** from a left hand side, in such a manner that the erector heads **120a**, **120b** may both be moved along the same longitudinal and vertical path. The common path of erector heads **120a**, **120b**, may be a cyclical path that lies substantially in or is parallel to a plane that it parallel both vertical axis Z and longitudinal axis Y in FIG. 7. Thus movement of the erector heads **120a**, **120b** may only be in vertical Z and longitudinal Y directions (i.e. directions parallel to axes Z and Y in FIG. 7), and there may be no substantial movement in a lateral Z direction (i.e. a direction parallel to axis X in FIG. 7). If the movement of the erector heads **120a**, **120b** is restricted to only Z and Y directions, a moving apparatus for each can be constructed that is relatively less complex than if movement in all three directions is required.

The movement of heads **120a**, **120b** by movement apparatuses **115a**, **115b** respectively, may be synchronized such that they may travel along the same longitudinal and vertical path but they move out of phase with each other so that one erector head does not interfere with the other erector head, as will be described further below. Thus, the relative positions of the two erector heads **120a**, **120b** can be arranged so that the heads they do not collide or otherwise interfere with each other during operation of system **100**.

Only the detailed construction of left side movement apparatus **115b** will be described herein, it being understood that movement apparatus **115a** may be constructed in a substantially identical manner as a mirror image of moving apparatus **115b**. With particular reference to FIGS. 4, 5, 7, 8, 9 and 17, movement apparatus **115b** may include a vertical movement device and a horizontal movement device. The vertical movement device may include a generally hollow vertically oriented support tube **169** that may be generally rectangular in cross section. Support tube **169** may be formed from a unitary tubular piece of material or may be formed into opposed, vertically extending and oriented, surfaces **164**, **165**, **166** and **168** that may be inter-connected together using conventional mechanisms such as bolts,

welding etc. Support tube **169** may be secured to a horizontally extending brace plate **182**. Brace plate **182** may be interconnected to a vertically extending brace plate **180**. The bottom portion of brace plate **180** may be interconnected by way of a series of angled plates generally referred to as **183**, to the lower end of support tube **169**.

At the upper end of support tube **169** may be mounted a freely rotatable pulley wheel **155b**. At the bottom end of plates **164**, **166**, erector head **120b** may be fixedly attached to support tube **169** by means of a horizontally extending mounting plate that is connected to support tube **169**, which engages with a pair of spaced mounting block **190a**, **190b** that may be joined with bolts through bolt holes **191a**, **191b** in blocks **190a**, **190b** that also pass through the mounting plate at the bottom of support tube **169**. Thus, as erector head **120b** is interconnected to support tube **169**, erector head **120b** will move in space with support tube **169**.

To support the support tube **169** and erector head **120b** that is connected thereto, and facilitate movement of the support tube **169** and erector head **120b** in horizontal motion, a horizontal movement device may be provided and may include a slide block **158** that may use a rail system to move horizontally and may be provided with a pair of spaced, longitudinally and horizontally extending short inner blocks, each one fitting on one longitudinally extending rail **160**, **162** that holds the blocks securely but allows blocks to slide horizontally relative to the rails. An example of a suitable rails system is the Bosch Rexroth ball rail system in which the rails are made from steel and the blocks have a race of ceramic balls inside allowing the block to slide on the rails. Rails **160**, **162** are generally oriented horizontally and may be attached to the frame **109**. Slide block **158** may be mounted to rails **160** or **162** for horizontal sliding movement along the rails. Secured to the front face of slider block **158** are four freely rotatable pulley wheels **155a**, **155c**, **155d** and **155f** which have drive belt **153** pass around them as described below. Slide block **158** may also use a rail system to allow support tube **169** to be connected to it and also move vertically relative to slide block **158**. Accordingly, extending vertically along a back surface of tube **169** may be a vertically and longitudinally extending rail. Support block may have a runner block interconnected to the vertical rail on support tube **169**. Thus support tube **169** can slide horizontally relative to slide block **169**. Again, a suitable rail system is the Bosch Rexroth ball rail system referenced above.

A drive apparatus may also be provided to drive the horizontal movement device and the vertical movement device. For example, the drive apparatus may include a pair of drive motors interconnected to a drive belt, with the drive belt being inter-connected to the horizontal and vertical movement devices. For example, the drive apparatus may include a left belt drive motor **150** (which may be a servo motor such as the model MPL-B330P-MJ24AA made by Allen Bradley) may be mounted to a longitudinally extending beam member **108** that is connected to frame **109** (see FIGS. 1a, 2 and 3). Servo drive **150** may have a drive wheel **152**. Similarly, a right belt drive **154** (which may be a servo motor like servo drive **150**) may also be mounted to beam member **108** connected to frame **109**. Servo drive **154** may have a drive wheel **156**. Servo motor **152** may be longitudinally spaced from, and may be horizontally aligned with, servo motor **154**. Both servo motors **150** and **154** can be driven in both directions at varying speeds, such rotation being controllable through servo drives by PLC **132** (see FIG. 1b). Both servo motors **150** and **154** may be provided with two separate ports **364a**, **364b**. One for the ports may

be for supplying a power line and the other for a communication line to facilitate the communication with the servo drive and PLC 132. It should be noted that all of the servo motors described in this document may be similarly equipped. Servo motors 150, 154 may also have a third input which may provide input for an electric braking mechanism.

Apparatus 115a may also include a continuous drive belt 153 that may for example be made from urethane with steel wires running through it. Belt 153 may be engaged and may be driven by motors 150 and 154 under control of PLC 132 as it may independently control through their respective servo drives, the operation of both servo motor 152 and servo motor 154. Belt 153 extends continuously from a start location at the bottom left side of support tube 169, where belt is fixedly attached to a belt block 159a that is attached to support tube 169. From there belt extends upwardly on a first portion 153g to block pulley 155f, around the upper side of block pulley 155f. From block pulley 155f, belt 153 extends horizontally along a second portion 153h to servo drive wheel 152. The belt then passes around and is engaged by servo drive wheel 152, on a third portion 153a on the underside of pulley 155a, upwards along a fourth portion 153b to pulley 155b. From there belt extends around pulley 155b, downwards on a fifth portion 153c to block pulley 155c, around block pulley 155c along a sixth portion 153d to servo drive wheel 156. After passing around and being engaged by servo drive wheel 156, belt 153 extends continuously from around servo drive wheel 156, on to a seventh portion 153e to the upper side of block pulley 155d. From block pulley 155d, belt 153 then extends vertically downwards along an eighth portion 153f to belt block 159b where the belt terminates. Belt 153 vertically supports the support tube 169 both at the bottom as it is interconnected to support tube 169 with blocks 159a, 159b, and at the top of support tube 169 where it passes 155b. Thus belt 153 is indirectly also vertically supporting erector head 120b. Furthermore, by adjusting the relative rotations of servo drive wheels 152 and 156, the relative lengths of all belt portions can be adjusted through the operation of the servo motors 150 and 154. Thus, the relative vertical position of support tube 169 relative to slide block 158 can be adjusted. Additionally, by adjusting the relative rotations of servo drive wheels 152 and 156, through the operation of the servo motors 150 and 154 the horizontal position of slide block 158 on rails 160, 162 can be adjusted thus altering the horizontal position of support tube 169 and erector head 120b. It will thus be appreciated that by adjusting the direction and speeds of rotation of drive wheels 152, 156 relative to each other the support tube 169 can be moved vertically and/or horizontally in space within the physical constraints imposed by among other things the position of the servo drive wheels 152 and 156, the length of the belt 153, and the length of support tube 169. The following will be appreciated with reference to FIG. 17 in particular:

If wheels 152 and 156 both remain stationary then the position of support tube 169 will not be altered;

If wheels 152 and 156 both rotate in the same clockwise direction and at the same speed relative to each other, then support tube 169 (and thus erector head 120b) will move horizontally from right to left;

If wheels 152 and 156 both rotate in the same counter-clockwise direction and at the same speed relative to each other, then support tube 169 (and thus erector head 120b) will move horizontally from left to right;

If wheel 152 rotates counter-clockwise, and wheel 156 rotates in opposite clockwise rotational directions, but both wheels rotate at the same rotational speed relative

to each other, then support tube 169 (and thus erector head 120b) will move straight vertically downward;

If wheel 152 rotates clockwise, and wheel 156 rotates in opposite counter-clockwise rotational directions, but both wheels rotate at the same rotational speed relative to each other, then plates 164, 166 will move straight vertically upwards.

It will be appreciated that if the speeds and directions of the two servo motors are varied in different manner, then the motion of the support tube 169 (and thus erector head 120b) can be created that has both vertical upwards or downwards component as well as a horizontally right to left, or left to right movement. Thus any desired path within these two degrees of freedom (vertical and horizontal) can be created for support tube 169 (such as a path having curved path portions) (and thus erector head 120b). Thus by controlling the rotational direction and speed of the motors 150, 154 independently of each other, PLC 132 can cause support tube 169 (and thus erector head 120b) to move along any path, within the physical constraints imposed by the spacing of the drive wheels 152, 156 and pulley wheel 155b, and the bottom of support tube 169 in vertical and horizontal directions to allow for the end erector 120b to carry a carton blank 111 through the various processing steps performed by system 100.

It will also be appreciated that by providing two opposed moving apparatuses 115a, 115b, the movements of each of the end effectors 120 can be co-ordinated and synchronized so that even though they move along the same path, the movement of the end effectors are out of phase (for example by 180 degrees).

Thus the movements of one end effector will not interfere with the movement of the other. An encoder may be provided for each of the servo drive motors 150 and 154 and the encoders may rotate in relation to the rotation of the respective drive wheels 152, 156. The encoders may be in communication with, and provide signals through the servo drives to PLC 132. Thus PLC 132 can in real time know/determine/monitor the position of the belt 153 in space and thus will determine and know the position of the erector head 120b in space at any given time. The particular types of encoders that may be used are known as "absolute" encoders. Thus the system can be zeroed such that due to the calibration of both encoders of both servo drives 150 and 154, the zero-zero position of the erector head in both Z and Y directions is set within PLC 132. The zero-zero position can be set with the erector head at its most horizontally left and vertically raised position. PLC 132 can then substantially in real time, keep track of the position of the erector head 120b as it moves through the processing sequence for a blank 111.

PLC 132 and the encoders associated with the servo motors 150, 154 and their servo drives on each of apparatuses 115a, 115b may be capable of being able to be set at zero-zero positions for each of the two separate erector heads 120a, 120b. PLC 132 can then substantially in real time, keep track of the position of both the erector heads 120a, 120b as they both independently move through the processing sequence for a blank 111.

Also associated with moving apparatus 115b is a first, generally horizontally oriented caterpillar device 114 having an input end 114a and an output end 114b. A second, generally vertically oriented caterpillar device 118 is also provided and has an input end 118a, and an output end 118b. Caterpillars 114 and 118 may have a hollow cavity extending along their length. Within the cavities of caterpillars 114, 118 hoses/wires carrying pressurized air/vacuum and elec-

trical/communication wires can be housed. Caterpillar **114** allows such hoses and wires to move longitudinally as the support tube **169** and erector head **120b** are moved longitudinally. Caterpillar **118** allows such hoses and wires to move vertically as the support tube **169** and erector head **120b** are moved vertically. The hoses and wires may extend from external sources to enter at an inlet **114a** of caterpillar **114** and emerge at an outlet **114b**. Once leaving outlet **114b**, the hoses and wires may extend to enter at an inlet **118a** of caterpillar **118** and emerge at an outlet **118b**. These hoses and wires may then pass from outlet **118b** into the input hoses **190** and **191** on erector head **120b** (see FIG. **30**). In this way both pressurized air/vacuum and/or electrical communication wires may be brought from locations external to the frame **109** onto the moving erector head **120b**. An example of suitable caterpillar devices that could be employed is the E-Chain Cable Carrier System model #240-03-055-0 made by Ignus Inc. It should be noted that electrical communication between the PLC **132** and the erector head **120b** could in other embodiments be accomplished using wireless technologies that are commercially available.

Turning now to FIGS. **30** to **33**, left hand side erector head **120b** is shown in isolation. Right hand side erector head **120a** may be constructed in the same manner as erector head **120b**, but may be supported from the right hand side moving apparatus **115a**, in contrast to erector head **120b** which may be supported from the left hand side by left hand moving apparatus **115b**.

Erector head **120b** may have a body generally designated as **300** that may comprise of a number of components. Many of the components of erector head **120b** may be made from a strong material such as a metal (e.g. aluminium, steel, etc.), a hard and strong plastic such as or other suitable materials including composite materials.

Erector head **120b** may be generally configured to handle a range of sizes of carton blanks **111** that can be formed into a carton. Erector head may be configured by providing easy attachment to support tube **169** using mounting blocks **190a**, **190b** and bolts etc. to permit for the easy interchange of erector heads **120** so that the system can in some circumstances, be readily adapted to forming differently sized/shaped cartons from differently configured blanks.

In one embodiment, erector head **120b** may include a rotatable paddle **310** connected to a distal end portion **314a** of a paddle arm **314**. Paddle arm **314** may have an end portion **314b** opposite to distal end portion **314a**, that is formed with a circular opening that facilitates arm **314** being connected to a shaft **316**. Paddle **310** can rotate with shaft **316** about the longitudinal axis of shaft **316**. Shaft **316** may be connected to a rotary actuator **399** such as a double acting rotary pneumatic actuator manufactured by Festo under engineering part #DSM-32-270-CC-FW-A-B. Actuator **399** can cause rotation of shaft **316** clockwise and counter-clockwise around its axis of up to 270 degrees. Rotary actuator **399** may be supplied with pressurized air supplied by hoses (not shown) connected to ports **395** and **397**. Those hoses may also be connected to a solenoid valve device **340** which may be controlled by PLC **132**. In this way the rotation clockwise and counter-clockwise of paddle **310** may be controlled by PLC **132**.

Also formed as part of body **300** of erector head **120b** is a bottom suction plate **327** that is generally shaped in a square cross configuration to provide flanged openings for such cups. In each of the open flanges of plate **327** is positioned a suction cup **312**. It should be noted that while many types of suction cups may be employed on the erector head, a preferred type of suction cup is the model

B40.10.04AB made by Piab. Two of the suction cups **312** are mounted to a generally longitudinally oriented support block **319a** and the other two suction cups are mounted to a second generally longitudinally oriented support block **319b**.

Support blocks **319a** and **319b** are generally oriented longitudinally in space apart, parallel relation to each other and each block **319a**, **319b** is joined to other body components of body **300**. Blocks **319a**, **319b** each have open passageways that interconnect each suction cup **312** with an outlet from a vacuum generator **330**. Vacuum generator **330** may be any suitable vacuum generator device such as for example the model VCH12-016C made by Pisco. Vacuum generators **330** each have an inlet interconnected to a hose (not shown) that can carry pressurized air to the vacuum generator. The vacuum generator converts the pressurized air supplied to the inlet port, into a vacuum at one of the outlet ports. That vacuum outlet port is interconnected through the passageway in blocks **319a**, **319b** to a suction cup **312** so that the suction cup can have a vacuum force. Interposed along the pressurized air channel running between each vacuum generator **330** and the source of pressurized air that may be an air compressor (see FIG. **1b**), may be located a solenoid valve device **340** that may for example be a model CPE14-M1BH-5L-1/8 made by Festo. Valve device **340** may be in electronic communication with PLC **132** and be controlled by PLC **132**. In this way PLC **132** can turn on and off the supply of vacuum force to each of the suction cups **312**. To channel the compressed air appropriately, valves in valve device **340** can be driven between open and closed positions by solenoids responsive to signals from PLC **132**. Electrical lines carrying signals to and from PLC **132** could also pass through hose **190** to operate the valve device **340**.

Still with reference to FIGS. **30** to **33**, downward extending end portions **323** of longitudinal support block **319** have openings **331** that are configured to receive a transversely mounted shaft **342**. Shaft **342** may be mounted for rotation within openings **331**. At one end of shaft **342** may be mounted a gear wheel device **360** that is configured to rotate with shaft **342**. Gear wheel **360** may be interconnected to a drive wheel of a gear box **362** to form a mitre gear connection. Gear box **362** may be driven by a servo motor **364** mounted above gear box **362**. Servo motor **364** may also be a model MPL-B1530U-VJ44AA made by ALLEN BRADLEY and gear box may be a model AER050-030 FOR MPL-A1520 AB SERVO MOTOR made by Apex.

In FIG. **30**, servo motor **364** is shown with two separate ports **364a**, **364b**. One for the ports may be for supplying a power line and the other for a communication line to facilitate the communication with the servo drive and PLC **132**. It should be noted that all of the servo motors described in this document may be similarly equipped. Servo motor **364** may, through connection with a servo drive (see FIG. **1b**), be controlled by and be in communication with PLC **132**. An encoder may be provided within or in association with servo motor **364** and the encoder may rotate in relation to the rotation of the respective drive shaft of the servo motor. The encoder may be in communication with, and provide signals to the servo drive and thus to PLC **132**. PLC **132** may be able to determine the rotational position of the shaft **342**. Thus, when appropriate signals are provided from PLC **132**, so servo motor **364** can be operated and can cause shaft **342** to rotate in a particular desired direction at a particular desired rotational speed for a desired amount of time. Thus PLC **132** can control the rotational position of shaft **342**.

Mounted to shaft **342** between end portions **323** of support blocks **319a**, **319b** is a rotator device generally designated **350**. Rotator device **350** is fixedly attached to shaft **342** and will rotate with shaft **342**. Rotator device **350** includes an arm **351** having one end fixedly mounted to shaft **342**. The opposite end of arm **351** has a mounting block **353** attached to it.

Secured to mounting block **353** may be a pneumatic actuator **325** that may for example be a model DFM-12-80-P-A-KF, or part #170905 made by Festo. Actuator **325** may be supplied with pressurized air to activate the device that may be controlled by solenoid valve device **340** in the supply line. The solenoid valve **340** may be in communication with and be controlled by PLC **132** (see FIG. **1b**). Actuator **325** may be actuated to reciprocate piston arms **326** between an extended position and a retracted position. PLC **132** may send a signal to valve device **340** to operate actuator **325** to extend piston arms **326** at a particular angular position of arm **351** and/or location of erector head **120b** that is provided by the encoder associated with servo motor **364**. Similarly, PLC **132** may send a signal to valve device **340** to activate arms **326** to be retracted at a particular shaft **342** angular position, and to retract piston arms **326** at a particular angular position, of arm **351** and/or a particular location of erector head **120b**. PLC **342** may cause, acting through valve device **340**, actuator **325** to be actuated at approximately the same time as the cups **320** have contacted the surface of downward facing panel D and/or when rotation of arm **351** is just about to begin or has just commenced. Piston arms **326** may be completely extended by the time arm **351** has rotated about 45 degrees.

Mounted to distal ends of piston arms **326** is a mounting block **328** which may be configured to support a pair of suction cups **320**. Blocks **328** may have open passageways (not shown) that interconnect each suction cup **320** with an outlet from another vacuum generator **330**. Vacuum generator **330** may be any suitable vacuum generator device such as for example the model VCH12-016C made by Pisco. As indicated above, vacuum generators **330** each have an inlet interconnected to a hose (not shown) that can carry pressurized air to the vacuum generator. Vacuum generators **330** convert the supplied pressurized air supplied the inlet port to a vacuum at one of the outlet ports. That vacuum port is interconnected through the passageway in block **328** to a suction cup **320** so that the suction cup can have a vacuum force. Interposed along the pressurized air channel running between each vacuum generator **330** associated with suction cups **320** and the source of pressurized air may be located the same valve device **340**. Valve device **340** may be interconnected electronically (either with a wireless system or wired communication connection) to PLC **132** and be controlled by PLC **132**. In this way PLC **132** can also turn on and off the supply of vacuum force to each of the suction cups **320**.

With reference also to FIG. **11**, suction cups **312** can be employed to engage and hold onto the top panel A of blank **111**. Once a blank **111** is retrieved from the top of the stack of blanks, the rotator arm **351** can be rotated approximately 180 degrees such that suction cups **320** of rotator device **350** can engage and hold onto the underside panel D of blank **111**. Once suction cups **320** have engaged panel D the arm **351** can be rotated 90 degrees backwards in the opposite rotational direction and the opposing vacuum forces created by suction cups **312** above and suction cups **320** below, cause the tubular blank **111** to be moved from a flattened configuration to an open configuration as panel D is rotated substantially 90 degrees relative to panel A. The air suction

force that may be developed at the outer surfaces of suction cups **320** and **312** will be sufficient so that when activated they can engage and hold top panel A in a stationary position relative to erector head **120b** and rotate panel D relative to panel A to open up the tubular blank to a generally rectangular configuration. The vacuum generated at suction cups **320** and **312** can also be de-activated by PLC **132** at appropriate times by sending signals to valve device **340**.

Each erector head **120a**, **120b** may be configured to be able to handle a wider range of different sized/dimensioned blanks **111** by providing for additional suction cups **320** and **312** positioned at different locations on the erector heads. Suction cups **320**, **312** could each be "self-sealing" or "self-plugging" suction cups which if not engaging and sealing with a surface of a particular blank that is being processed, may automatically become blocked. This would allow the vacuum/suction forces to be maintained on other suction cups that may have the source of pressurized air/vacuum interconnected thereto and which are engaging a panel of a blank **111**. In this way, each erector head may be adapted to handle a wider variety of sized/dimensioned blanks and cartons/cases that can be formed therefrom.

The opening of the blank **111** may be assisted by the extension of piston arms **326** of actuator device **325** during rotation of the rotator arm **351**. Preferably when rotator arm **351** has rotated somewhere in the range of about 30-60 degrees back to the 90 degree position, and preferably when it is at approximately 40-50 degrees, and most preferably when it is at about 45 degrees, then the piston arms **326** may be fully extended. This extension of arms **326** and thus of suction cups **320** in a generally tangential direction relative to the rotation of arm **351** compensates for the offset of the axis of rotation of the arm **351** compared to the axis of rotation of the blank that extends along the fold line between panels A and D. The effect of the extension of piston arms **326** once the arm is rotated such as to 90 degrees ensures that the panel D is also oriented at 90 degrees to panel A.

Once a blank **111** has been opened to the configuration shown in FIG. **11**, then PLC **132** can send a signal to valve device **340** which causes rotary actuator **399** to rotate shaft **316** and thus rotate paddle **310**. Paddle **310** can then engage trailing flap K of blank **111** and cause it to fold about its fold line where it joins to panel D. Thus flap K can be folded inwards towards the bottom opening of blank **111**. Leading bottom flap J may also be folded about its fold line which joins it with panel B by engagement of the flap with upper and lower folding rails/ploughs **700**, **701** that form part of folding and sealing apparatus **130**. As the blank **111** held by erector head **120b** is moved longitudinally downstream into the folding and sealing apparatus **130** the leading bottom flap J can be folded inwards so that both bottom flaps K and J are folded inwards to start the formation of the bottom of the carton.

Another feature of erector head **120b** that can be noted is that a carton location sensor apparatus may be provided and may include a reciprocating sensor rod **380** which, when not in contact with a blank, extends downwards through an aperture **381** in plate **327**, below the level of the plane of suction cups **312**. When the erector head **120b** is brought vertically downwards to retrieve a blank on a stack of blanks **111** in magazine **110**, the erector head's movement just prior to suction cups **312** contacting with the upper surface of the blank will be generally vertically downwards. Prior to the suction cups **312** contacting the surface of a panel A of a blank, sensor rod **380** will engage the surface of panel A and cause sensor rod **380** (which may be resiliently displaced due to a spring mechanism biasing the rod downwards) to be

pushed upwards. This movement upwards of sensor rod **380** relative to plate **327** will physically cause a sensor (not shown) to be activated and send a signal to PLC **132**. The sensor may be an inductive proximity sensor. The metal cylinder fixed on the rod is sensed by the sensor's circuitry because it changes the inductance of the induction loop inside the sensor. The sensor may be 871FM-D8NP25-P3 made by ALLEN BRADLEY. PLC **132** may respond to that signal by causing servo drives **150** and **154** to slow down so that the final few centimeters (e.g. 3.5 cm) of movement downwards towards contact between cups **312** and the upper surface of panel A occurs at a much slower rate and also PLC knows how much further vertically downwards erector head **120b** must be lowered to establish proper contact between suction cups **312** and panel A. It should also be that sensor rod **380** and associated sensor device can also be used to ensure that PLC **132** is aware of whether once a blank has been engaged in the magazine **110**, it stays engaged with erector head **120** until the appropriate release location is reached, such as once erection of the carton has been completed.

The particular arrangement of suction cups and rotating paddle on erector heads **120** can be designed based upon the configuration of the carton blank and the particular panels and flaps that need to be rotated. It will also be appreciated that on erector head **120** that is illustrated, suction cups are used to apply a force to hold and/or rotate panels of a carton blank. However alternative engagement mechanisms to suction cups **312** and **320** could be employed.

With particular reference to Figures including FIGS. **1** to **15** and **17**, system **100** may also include a folding and sealing apparatus **130**. Rail and plough apparatus may be configured to cause all remaining flaps of a blank **111** to be appropriately folded and sealed to produce a carton configuration that is suitable for delivery to a discharge conveyor such as discharge conveyor **117**. Apparatus **130** may include the following components: upper and lower folding rails/ploughs **700** and **701**; a carton support plate **703**; a discharge chute **750**; an upper flap closing device **705**; a lower flap closing device **707**; a right hand compression device **706**; and a left hand compression device **704**; and a glue applicator **709** (see FIG. **1**) having one or more nozzles positioned to apply adhesive to flaps such as flaps J and K. Each of the rails and actuator devices of apparatus **130** may be supported by rods or other members to interconnect the components to support frame **109**.

Upper flap actuation device **705** may include a pneumatic actuator device **704a** having its piston arms connected to an upper plough **708a**. Similarly, lower flap actuation device **707** may include a pneumatic actuator device **704b** having its piston arms connected to an upper plough **708b**. Actuator devices **704a**, **704b** may be the model DFM-25-100-P-A-KF, part #170928 made by Festo.

Right hand compression device **706** may include a central pneumatic actuator **710** with telescoping extendible support rods **712** and **714** horizontally aligned and disposed on either side of actuator **710**. Actuator **710** may be a model DNC-32-100-PPV-A part #163309 made by Festo. With particular reference to FIG. **26**, actuator **710** may have piston arms that along with ends of support rods **712** and **714** connected to a longitudinally extending sealing plate **716** having attached thereto longitudinally extending upper rail **717a**, and lower rail **717b**. Upper rail **717a** is positioned to be able to engage upper major flap F and lower rail **717b** is positioned to engage lower major flap G when piston arms of actuator device **710** are extended horizontally and transversely

inwards to push flaps F and G into engagement with flaps K and J that are positioned underneath.

Left hand compression ram device **704** has an actuator arm **711** which may be actuated by an actuator device **719** with a vertically and longitudinally disposed plate **720** attached to the end of the actuator arm. Actuator device **719** may be a double acting pneumatic actuator (not shown) that may be provided with pressurized air through hoses, with the air flow being controlled by the solenoid valve device that may be controlled by PLC **132**. Other embodiments are possible. For example, with reference to FIG. **26A**, a servo-driven actuator for arm **711** may be provided that includes a mounting block **741** that can travel along a rail guide **745** that is secured to a horizontal and longitudinally extending plate forming part of a support frame **746**. Mounting block **741** can slide horizontally along rail **745**. An L-shaped plate **743** interconnects arm **711** to sliding block **741**. Sliding block **741** may also be connected such as with nuts and bolts on its underside to a drive belt **757** made of any suitable material such as for example the same material that may be used in the belts for the moving apparatuses **115**—namely a urethane timing belt with steel wires running through it. Continuous drive belt **757** may extend between a freely rotating pulley **759** mounted to an end of frame **746**, and a drive wheel of a servo motor **761**. Through a servo drive and an absolute encoder. Servo motor **761** may be an Allen Bradley model AB MPL-B320P-MJ22AA and may be interconnected with servo drive to PLC **132**. The servo drive may be Allen Bradley model AB. 2094-BM01-S. Motor **761** may be coupled to drive wheel for the belt through an APEX GEARBOX model AE070-005.

PLC **132** may control the rotation of the drive wheel driven by the servo motor **761** through use of an encoder (that may be an absolute encoder). Thus the movement of belt **757** can be controlled and PLC can determine in real time, the position of ram arm **711** and thus of compression plate **720**. Depending upon the type of, and thickness of material from which blank **111** is formed, the positioning of plate **720** relative to the plate of right hand compression device **706** can be adjusted by PLC **132** to ensure an appropriate degree of compression of the flaps of blank **111** positioned there between.

Each of actuator devices **704a**, **704b**, **710** may be double acting cylinders and they may be supplied with pressurized air that is controlled through an electronic valve device (not shown). The valve device may be a model CPE14-M1Bh-5J-1/8 valve unit that may be in communication with and be controlled by PLC **132**. In this way, PLC **132** can cause the piston arms to be extended and retracted during the processing of carton blanks to achieve the closure and sealing of the flaps.

Actuator device **704a** and its plough **708a** may be appropriately positioned and angled downwards (such as at about 45 degrees to the vertical) to be able to fold down major flap F sufficiently to be able to be engaged by right hand compression device **706**. Similarly, actuator devices **704b** and its plough **708b** may be appropriately positioned and angled upwards (such as at about 45 degrees to the vertical) to be able to fold up major flap G sufficiently to be able to be engaged by right hand compression device **706**, substantially simultaneously, or at least allowing of right hand compression device **706** to be able to compress both flaps F and G at the same time towards minor flaps J and K that have upper surfaces containing some adhesive.

Applicator **709** can have nozzles appropriately positioned and their operation may be controlled by PLC **132**. Applicator **709** can apply a suitable adhesive to flaps such as

leading minor flap J and trailing minor flap K, once they have been folded inwards to form part of the carton bottom. An example of a suitable applicator **709** that can be employed is the model ProBlue **10** applicator made by Nordson Inc. An example of a suitable adhesive that could be employed with on a carton blank **111** made of cardboard is Cool-Lok 034250A-790 adhesive available from Lanco Adhesives, Inc. Applicator **709** may be in electronic communication with PLC **132** which can signal the applicator to apply adhesive at an appropriate time during the positioning of the erector heads **120a**, **120b**

Left hand compression device **704** may be used to enter the carton from the left side and compress flaps F, G, J and K between ram plate **720** of left hand compression device **704** and the rails **717a**, **717b** of right hand compression device **706**. This compression assists in ensuring that the panels are compressed together to ensure that the adhesive appropriately bonds the flaps together to make a solid carton bottom.

In some embodiments, once the left hand compression device **704** and right hand compression device **706** have completed the compression of the flaps, PLC **132** can send a signal to solenoid valve devices causing the compression devices to be withdrawn. The carton will then have been fully erected and is suitable to be loaded with one or more items. Erector head **120b** may then carry the erected carton to a discharge chute **750** and then release it such that it falls onto discharge conveyor **117** which can then move the erected carton away for further processing. In other embodiments such as the one illustrated, the erected carton **111** can be released and fall onto support plate **703** and remain there until the next carton blank carried by another erector head moved by another movement apparatus (such as erector head **120a** moved by movement apparatus **115a**) moves the next carton blank into the location where it will be folded, sealed and compressed. In doing so the newly arrived carton blank pushes the previous fully erected carton downstream where it may fall onto discharge conveyor **117**. Carton discharge conveyors are well known in the art and any suitable known carton conveyor may be utilized.

Other examples of transfer devices that might be employed to transfer the carton from apparatus **130** to a carton discharge conveyor include a “blow-off” system that may use one or more jets of compressed air, a suction cup system, the use of pushing arm or simply allowing for freefall of the formed carton.

A sensor **243** (see FIG. 2) such as an electronic eye model 42KL-P2LB-F4 made by ALLEN BRADLEY may be located near the bottom of discharge chute **750**. Sensor **243** may be positioned and operable to detect the presence or absence of an erected carton at the input to the discharge conveyor **117**. In this way, PLC **132** can be digitally signalled if an erected carton blank **111** is in place at the bottom of the chute **750** such that another erected carton can not be discharged down the chute **750**. If so, the system **100** can be stopped by PLC **132** until any fault at discharge conveyor **117** can be rectified.

The overall operation of system **100** will now be described further.

As an initial step PLC **132** may be accessed by an operator through HMI **133** to activate system **100**. The system **100** may be initialized with PLC **132** ensuring that all components are put in their “start” positions. At substantially the same time, a stack of cartons may be placed at the input end of conveyor **204** and system **100** may then be activated (such as by PLC **132** being instructed through HMI **133** to commence the processing of a stack of blanks **111**.

PLC **132** may then send an instruction to the drive motor of input conveyor **204** to commence to drive belt **214** causing stack of blanks **111** to move downstream. Sometime prior to the stack of blanks reaching alignment conveyor **206**, the right-hand-side magazine side guide wall **201** under control of PLC **132** will be driven by servo motor **260** to expand wide enough to allow the stack of blanks to enter on alignment conveyor **206**, even if the stack is misaligned and/or the blanks in the stack are not perfectly square with each other. The stack of blanks is moved downstream, until once the front edge of the stack of blanks passes the downstream edge of conveyor **204**, sensor **242** will send a signal to PLC **132** indicating that the front edge of the stack has reached the input to alignment conveyor **206**. In response, PLC **132** may then send an instruction to the drive motor of input conveyor **204** to commence to drive belt **216** causing stack of blanks **111** to move downstream towards end wall **218** of magazine **110**. Once the front edge of the stack of blanks **111** reaches end wall **218**, sensor **240** will send a signal to PLC **132** indicating that the front edge of the stack of blanks has reached end wall **218**. In response, PLC **132** can then initiate the tampering sequence to “square up” the stack of blanks, as detailed above.

In review, the tampering sequence for ensuring the blanks are properly squared up at the pick up location steps, may include the following steps. The tampering actuator **276** may be extended having been activated by pressurized air controlled by PLC **132** and the associated valve. Then the side guide wall **201** may contract to make contact with the side of the case stack and press the side wall **201** against the left hand side guide wall **200**. This aligns the cases so the side edges of blanks are aligned with each other and the longitudinal side wall of the walls **200** and **201**. The tampering actuator **276** may then retract, and the tampering bar **280** press the stack forward, thereby aligning the blanks in the stack so that their front and rear edges are vertically aligned with each other and with the inner face of the bar **280** and the inside surface of front wall **218**. The stack of blanks **111** is then properly positioned so that the erector heads **120a** and **120b** can begin picking up blanks from the stack.

One of the erector heads such as erector head **120b** will be positioned by the control of PLC **132** over movement apparatus **115b**, at the zero position calibrated for the head **120b**. PLC **132** may then cause servo motors **150** and **154** to be operated to achieve the following sequence of operations:

First the head **120b** may be moved to the pick up position as shown in FIG. 17.

As the erector head **120b** is being brought vertically downwards to retrieve the top blank on a stack of blanks **111** in magazine **110**, the erector head’s movement just prior to suction cups **312** contacting with the upper surface of the blank will be generally vertically downwards. Prior to the suction cups **312** contacting the surface of a panel A of a blank, sensor rod **380** will engage the surface of panel A can cause sensor rod to be pushed upwards. This movement upwards of sensor rod **380** relative to plate **327** will physically cause the sensor to be activated and send a signal to PLC **132**. PLC **132** may respond to that signal by causing servo drives **150** and **154** to slow down so that the final few centimeters (e.g. 3.5 cm) of movement downwards towards contact between cups **312** and the upper surface of panel A occurs at a much slower rate. Also PLC knows how much further vertically downwards erector head **120b** must be lowered to establish proper contact between suction cups **312** and panel A. It should also be that sensor rod **380** and associated sensor device can

also be used to ensure that PLC 132 is aware of whether once a blank has been engaged in the magazine 110, it stays engaged with erector head 120 until the appropriate release location is reached, such as once erection of the carton has been completed.

PLC 123 will also operate the valve device 340 on head 120b to cause suction force to be developed at suction cups 312 and optionally also 320 (although suction at suction cups 320 can be delayed);

With the head 120b in the pick up position shown in FIG. 17 and the suction force being applied at suction cups 312, the head 120b can engage the panel A (see location of suction cup outline on FIG. 10A) and then commence to lift upwards the blank as shown in FIG. 18. PLC 132 will know how high to lift the upper surface of blank 111, to ensure that once opened up, the datum line W1 will be appropriately vertically located so that components of folding and sealing apparatus 130 will be able to fulfil their functions as described above.

Preferably when erector head 120b has reached a determined vertical position, and preferably while the erector head 120b is not moving longitudinally towards folding and sealing apparatus 130, PLC 132 will send a signal to cause servo motor 134 to rotate which will then cause shaft 342 to rotate in a particular desired direction at a particular desired rotational speed for a desired amount of time. PLC 132 can control the rotational position of shaft 342 to cause rotator device 350 which is fixedly attached to shaft 342 to rotate with shaft 342. Thus rotator device 350 may be rotated to the position shown in FIG. 19 and at that position suction cups 320, which will have suction engaged, will attach to the underside of blank 111, and in particular to panel D.

The next operation is the blank opening whereby through control of PLC 132, opposed forces provided by suction cups 312 acting upwards on top and suction cups 320 acting in an opposite downward direction will start to pull the flattened blank apart. The forces are then continued by the suction cups 312 above and 320 below, as rotator device 350 is rotated 90 degrees backwards to the position shown in FIG. 20.

During the backwards rotation of rotator device 350, actuator device 325 may be supplied with pressurized air controlled through valve device 340 to activate the actuator device. PLC 132 may send a signal to valve device 340 to operate actuator device 325 to extend piston arms 326 at a particular angular position of arm 351 and or location of erector head 120b that is provided by the encoder associated with servo motor 364. PLC 342 may cause, acting through valve device 340, actuator device 325 to be actuated at approximately the same time as the cups 320 have contacted the surface of downward facing panel D and the rotation of arm 351 is just about to begin or has just commenced. Piston arms 326 may be completely extended by the time arm 351 has rotated about 45 degrees. The piston arms 326 may continue to be extended and stay extended when rotator device 350 is at the 90 degrees position shown in FIG. 20.

Once the blank 111 has been opened, erector head 120b can securely hold the blank by the suction forces exerted by cups 312 and 320, to panels A and D. Also, once opened the flaps K and J need to be folded inwards towards the bottom opening of the carton. In the embodiment shown in Figures such as FIGS. 17 to 29, the trailing minor flap K is closed by actuation of

paddle 310 as shown in FIG. 21. Thus PLC 132 can send a signal to valve device 340 which causes rotary actuator 397 to rotate shaft 316 and thus rotate paddle 310. Paddle 310 can then engage trailing minor flap K of blank 111 and cause it to fold about its fold line where it joins to panel D. Thus, flap K can be folded inwards towards the bottom opening of blank 111.

Leading bottom flap J may also be folded about its fold line which joins it with panel B by engagement of the flap with upper and lower folding rails/ploughs 700, 701 that form part of folding and sealing apparatus 130 as erector heads 120b is moved longitudinally downstream towards apparatus 130. As the blank 111 held by erector head 120b is moved longitudinally downstream into the folding and sealing apparatus 130 the leading bottom flap J can be folded inwards by rails/ploughs 700, 701, so that both bottom flaps K and J have been folded inwards to start the formation of the bottom of the carton, as is shown in FIG. 22.

Also when the flaps K and J have been folded inwards, under the control of PLC 132, or pursuant to another control or trigger, adhesive applicator 709 can through appropriately positioned nozzles, apply a suitable adhesive at appropriate positions on the flaps K and J such as shown. The application of glue can occur before, during, or after PLC 132 has caused movement apparatus 115b to move erector head 120b to a downstream location where the major flaps F and G can be folded and compressed onto minor flaps K and J. As shown in FIG. 23, glue may be applied while movement apparatus 115b is moving erector head 120b to the downstream location for closing the bottom opening by folding and compression.

Next upper flap actuation device 705 may be activated by PLC 132 acting through a valve device to cause pneumatic actuator device 704a to extend piston arms connected to an upper plough 708a. Similarly, lower flap actuation device 707 may also be activated substantially simultaneously by PLC 132 such that pneumatic actuator device 704b extends its piston arms connected to lower plough 708b as shown in sequential FIGS. 24 and 25.

Next, as shown in FIG. 26, right hand compression device 706 with its central pneumatic actuator 710 may have piston arms extended so that longitudinally extending sealing plate 716 having attached thereto longitudinally extending upper rail 717a, and lower rail 717b engages the upper and lower major flaps F and J. Upper rail 717a is positioned to be able to engage upper major flap F and lower rail 717b is positioned to engage lower major flap G when piston arms of actuator device 710 are extended horizontally and transversely inwards to push flaps F and G into engagement with flaps K and J that are positioned underneath. Upper and lower flap actuation devices 705 and 707 may be withdrawn by PLC 132 when compression device 706 has engaged flaps F and G.

Next, as shown in FIG. 27, left hand compression device 704 may be used to enter the carton from the left side and compress flaps F, G, J and K between ram plate 720 of left hand compression device 704 and the rails 717a, 717b of right hand compression device 706. This compression assists in ensuring that the panels are compressed together to ensure that the adhesive appropriately bonds the flaps together to make a sold carton bottom.

Once the compression has been held for a short time (for example about 0.5 seconds) to allow the glue to suffi-

ciently set/harden and bond the flaps together, the compression can be released by withdrawing left hand compression device **704** and right hand compression device **706** as shown in FIG. **28**. The carton is then fully erected and released from both apparatus **130** and from erector head **120b** as PLC **132** will cause suction cups **320** and **312** to have their suction force turned off by valve device **340**. Additionally, PLC **132** can cause rotator device **350** to be rotated backwards a further 90 degrees to the horizontal ready position shown in FIG. **29**.

Thereafter, erector head **120b** can release the erected carton which can then fall onto support plate **703** and remain there until the next carton blank carried by another erector head moved by another movement apparatus (such as erector head **120a** moved by movement apparatus **115a**) moves the next carton blank into the location where it will be folded, sealed and compressed, and in doing so pushes the previous fully erected carton downstream to chute **750** where it may fall onto discharge conveyor **117**.

The entire sequence of movement of a blank **111** as it is processed by system **100** is shown in isolation in FIGS. **10A-D**, and FIGS. **11** to **16**. In FIGS. **10A-D** the blank is shown in its flattened tubular configuration. In FIG. **11** it is shown in its opened configuration after being opened by an erector head like erector head **120**. In FIG. **12** it is shown with the trailing minor flap **K** folded inwards and in FIG. **13** it is shown with leading minor flap **J** also folded inwards. In FIG. **14** blank **111** is shown with the major bottom flaps **F** and **G** folded inwards and in FIG. **15** the blank is shown when the flaps **J**, **K**, **F** and **G** are being or have been compressed to seal the bottom of the carton. Finally in FIG. **16** the erected carton is shown with its opening facing upwards so that it may be loaded with one or more items.

While the foregoing handling of a carton blank **111** by erector head **120b** has been occurring, erector head **120a**, being supported and moved by movement apparatus **115a**, can be carrying out the same process but do so out of phase with erector head **120b**. For example, the cyclical movement and operation of erector head **120a** may be 180 degrees out of phase with the movement and operation of erector head **120b**. By providing two erector heads **120a** and **120b** operating simultaneously, but out of phase so one does not interfere with the other, the processing capacity of blanks can be increased significantly. But in using only one erector head **120**, the processing capacity of the system **100** may still be relatively high. In part the relatively high processing capacity is also due to the relatively short "stroke" (i.e. longitudinal distance) that the erector heads must travel when carrying out the blank retrieval, erection, folding, sealing and compression. This means that the components do not have to travel such a great distance as in conventional carton erectors. When using two erector heads with moving apparatuses, **100** may be capable of processing about 35 cartons per minute.

Many variations of the embodiments described above are possible. By way of example only an alternate configuration for an erector head **1120** and folding and sealing apparatus **1130** is shown in FIGS. **34a** to **44**.

With reference to FIGS. **34a** and **34b**, erector head **1120** is built in substantially the same way as erector head **120** and functions in the same way apart from the following major differences. Erector head **1120** does not include a paddle member like paddle **320** on erector head **120**. As will be described hereinafter, the component and functionality for closing minor trailing flap **K** of a blank **111** can be moved off

the erector head and may become part of a modified folding and sealing apparatus **1130** (see for example FIG. **36**).

Erector head **1120** may have body generally designated **1330**, that includes a bottom suction plate **1327** that is generally shaped in a square cross configuration to provide flanged openings for such cups. In each of the open flanges of plate **1327** is positioned a suction cup **1312**. Suction cups **1312** are mounted with support blocks **1321** to a mounting plate **1322**. Also mounted with mounting blocks is a suction cup **1313** and optionally cups **1315**. Cups **1313** and **1315** may be employed to support a panel **B** of a blank **111** if the configuration of the panel and/or materials from which blank **111** is made, require additional support for the blank **111** at least when it is retrieved from the stack of blanks **111** in the magazine and even until the rotary actuator device **1350** (which may be substantially the same as rotary actuator **350** on erector head **120**) engages the bottom panel **D** of the blank prior to opening the blank.

In some applications, without the additional support provided by cup **1313** and possibly cups **1315**, the panels **B** and **C** may not remain in a generally flattened configuration when the blank is picked up by cups **1312** engaged with panel **A**.

It should be noted that suction cups and vacuum generators used on erector head **1120** may be same as used on erector head **120**. For simplicity, electrical cables and hoses for pressurized air are not shown on erector head **1120** but like erector head **120** can be installed in appropriate locations.

Also, a valve device like valve device **340** above, to control the flow of air is not shown but may be employed on erector head **1120** and may be in electronic communication with PLC **132** and be controlled by PLC **132**. In this way PLC **132** can turn on and off the supply of vacuum force to each the vacuum generators associated with each of the suction cups on erector head **1120**.

The sequence of opening a blank using erector head **1120** is shown in FIGS. **35a**, **35b**, and **35c**. Actuator **1325** may be actuated to reciprocate piston arms **1326** between an extended position and a retracted position. PLC **132** may send a signal to valve device to operate actuator **1325** (like actuator **325**) to extend piston arms **1326** at a particular angular position of arm **1351** and/or location of erector head **1120b** that is provided by the encoder associated with servo motor **1364** (like servo motor **364**). Similarly, PLC **132** may send a signal to valve device (not shown) to activate arms **1326** to be retracted at a particular shaft **1342** angular position, and to retract piston arms **1326** at a particular angular position, of arm **1351** and/or a particular location of erector head **1120**. PLC may cause, acting through valve device, actuator **1325** to be actuated at approximately the same time as the cups **1320** have contacted the surface of downward facing panel **D** and/or when rotation of arm **1351** is just about to begin or has just commenced. Piston arms **1326** may be completely extended by the time arm **1351** has rotated about 45 degrees. At the same time or sometime before, rotary actuator **1350** is activated to start the rotation, the PLC may through the valve device cause suction to be released from suction cup **1313** to allow panel **B** of blank **111** to rotate relative to panel **A**.

By way of further explanation, the two erector heads of system **100** can each in turn be employed to engage and hold onto the top panel **A** of blank **111**. Once a blank **111** is retrieved from the top of the stack of blanks, the rotator arm **1351** can be rotated approximately 180 degrees such that suction cups **1320** of rotator device **1350** can engage and hold onto the underside panel **D** of blank **111**. Once suction

cups **1320** have engaged panel D, suction at suction cup **1313** can be released and the arm **1351** can be rotated 90 degrees backwards in the opposite rotational direction and the opposing vacuum forces created by suction cups **1312** and possibly **1315** above, and suction cups **1320** below, can cause the tubular blank **111** to be moved from a flattened configuration to an open configuration as panel D is rotated substantially 90 degrees relative to panel A. The air suction force that may be developed at the outer surfaces of suction cups **1320** and **1312** and possibly **1315** will be sufficient so that when activated they can engage, hold top panel A in a stationary position relative to erector head **1120** and rotate panel D relative to panel A to open up the tubular blank to a generally rectangular configuration. The vacuum generated at suction cups **1320**, **1312**, **1313** and possibly **1315**, can also be de-activated by PLC **132** at appropriate times by sending signals to valve device, such as when it is appropriate to release the fully erected carton.

As with erector head **120**, on erector head **1120**, opening of the blank **111** may be assisted by the extension of piston arms **1326** of actuator device **1325** during rotation of the rotator arm **1351**. Preferably when rotator arm **1351** has rotated somewhere in the range of about 30-60 degrees back to the 90 degree position, and preferably when it is at approximately 40-50 degrees, and most preferably when it is at about 45 degrees, then the piston arms **1326** may be fully extended. This extension of arms **1326** and thus of suction cups **1320** in a generally tangential direction relative to the rotation of arm **1351** compensates for the offset of the axis of rotation of the arm **1351** compared to the axis of rotation of the blank that extends along the fold line between panels A and D. The effect of the extension of piston arms **1326** once the arm is rotated such as to 90 degrees ensures that the panel D is also oriented at 90 degrees to panel A.

Another feature of erector head **1120** that can be noted is that a carton location sensor apparatus may be provided and may include a reciprocating sensor rod **1380** which, when not in contact with a blank, extends downwards through an aperture **1381** in plate **1327**, below the level of the plane of suction cups **1312**. In a manner similar to sensor rod **380** in erector head **120b**, when the erector head **1120** is brought vertically downwards to retrieve a blank on a stack of blanks **111** in magazine **110**, the erector head's movement just prior to suction cups **1312**, **1313** and possibly **1315**, contacting with the upper surface of the blank will be generally vertically downwards. Prior to the suction cups contacting the surface of a panel A of a blank, sensor rod **1380** will engage the surface of panel A which can cause the sensor rod to be pushed upwards. This movement upwards of sensor rod **1380** relative to plate **1327** will physically cause a sensor (not shown) to be activated and send a signal to PLC **132**. Like in the previous embodiment, the sensor may be an inductive proximity sensor. The metal cylinder fixed on the rod is sensed by the sensor's circuitry because it changes the inductance of the induction loop inside the sensor. The sensor may be 871FM-D8NP25-P3 made by ALLEN BRADLEY. PLC **132** may respond to that signal by causing the movement apparatus (not shown but may be like apparatus **115b**) to slow down so that the final few centimeters (e.g. 3.5 cm) of movement downwards towards contact between cups **1312** and the upper surface of panel A occurs at a much slower rate and also PLC knows how much further vertically downwards erector head **1120** must be lowered to establish proper contact between suction cups and panel A. It should also be that sensor rod **1380** and associated sensor device can also be used to ensure that PLC **132** is aware of whether once a blank has been engaged in the magazine **110**,

it stays engaged with erector head **1120** until the appropriate release location is reached, such as once erection of the carton has been completed.

With reference now to FIGS. **36** to **44**, it will be observed that unlike with erector head **120**, with erector head **1120**, each opened blank is moved towards folding and sealing apparatus **1130** to fold both leading minor panel J and trailing minor panel K with the folding and sealing apparatus **1130**.

Folding and sealing apparatus **1130** mounted to a plate **1175** forming part of frame **1109** may be constructed in the same manner as apparatus **130** mounted to frame **109**, as described above. However, apparatus **1130** may be provided with an angled paddle device **1310** that is connected to a distal end of a paddle arm **1314**, that may be mounted to frame **1109**. Paddle arm **1314** may be connected to a shaft **1316** a rotary actuator **1399** for rotation therewith. The rotary actuator may be a double acting rotary pneumatic actuator manufactured by Festo under engineering part #DSM-32-270-CC-FW-A-B. Actuator **1399** can cause rotation of arm **1314** clockwise and counter-clockwise around its axis of up to 270 degrees. Rotary actuator **1399** may be supplied with pressurized air supplied by hoses (not shown) connected to ports **1395** and **1397**. Those hoses may also be connected to a solenoid valve device (not shown) which may be controlled by the PLC **132**. In this way the rotation clockwise and counter-clockwise of paddle **1310** may be controlled by PLC **132**.

Once a blank **111** has been opened to the configuration shown in FIG. **36**, then PLC **132** can send a signal to cause erector head **1120** to move towards apparatus **1130**. As shown in the sequence of FIGS. **37** to **39**, initially, leading minor flap J will be engaged by ploughs **1700** and **1701** to fold flap J inwards. While or after that is being completed, as shown in the sequence in FIGS. **40** to **42**, next the valve device can cause actuator **1399** to rotate shaft **1316** and thus rotate arm **1314** with paddle **1310** attached thereto. Paddle **1310** can then engage trailing flap K of blank **111** and cause it to fold about its fold line where it joins to panel D. Thus flap K can be folded inwards towards the bottom opening of blank **111**. Thereafter as shown partially in FIGS. **43** to **44**, the carton blank **111** held by erector head **1120b** can be moved longitudinally further downstream into the folding and sealing apparatus **130** where the minor flaps may be glued and the major top and bottom flaps F and G may be folded inwards and compressed, in substantially the same manner as described above in relation to erector head **120b** and movement apparatus **115b**.

The particular arrangement of suction cups and rotating paddle on erector heads **1120** can be designed based upon the configuration of the carton blank and the particular panels and flaps that need to be rotated. It will also be appreciated that on erector head **1120** that is illustrated, suction cups are used to apply a force to hold and/or rotate panels of a carton blank. However alternative engagement mechanisms to suction cups may be used.

In some embodiments, the flaps of the blank may be sealed by means other than a glue applicator. For example, it is possible to configure folding and sealing apparatus with an adhesive tape applicator that may apply tape to the bottom of the box once all minor and major flaps have been folded. In such an embodiment, compression of the flaps at the bottom of the erected carton may not be necessary. An example of such a set up is illustrated in FIGS. **50** to **52**. In this embodiment the folding and sealing stations like station **130** have been replaced by a folding and sealing station that includes a middle plough for folding a leading minor flap.

Thus both minor flaps can be closed by the middle plough for the leading minor flap and a paddle device like those described above for the trailing minor flaps. Upper and lower ploughs can be provided to fold over top of the minor flaps and then the moving apparatus can move an erector head **120** carrying a opened and flap folded blanks against the operational surface of an adhesive tape applicator. An example of a tape applicator that could be adapted for such use is a model Z59-557 supplied by Dekka Industries Inc. The folded bottom of the opened blank can then be moved longitudinally against the carton blank and tape could be started to be applied at a lower portion of panel B, over and along the middle join between flaps F and G, and the terminate at a lower portion of panel D.

In another embodiment, shown only schematically in FIG. 45, the system could be modified to employ one or more moving apparatuses **2115a**, **2115b** that may be substantially the same as moving apparatus **115a**, **115b**, and a magazine **2110** that may be substantially like magazine **110**. However, folding and sealing apparatus **130** or **1130** could be replaced/ or another device could be inserted above a support plate **2703** that has a discharge chute **2750**. A blank shoe device **2130** may be configured with interior guides. Erector head **2120a**, **2120b**, may be simplified devices controlled by PLC **132** which have only four suction cups **2130** that may be arranged in a generally rectangular configuration. Erector heads **2120a**, **2120b** may be readily interchanged in system **100** illustrated and described above for erector heads **120a**, **120b** and PLC **132** may operate another sequence of operations on erector heads **2120a**, **2120b** to process a blank **1111** (see FIG. 46) that may be used to form an open top tray. Suction cups **2130** may engage a blank **1111** that is configured to be formed into an open top tray. The moving apparatuses **2115a/b** may move a blank secured to a head **2120a/b** longitudinally from the magazine where it is retrieved from a stack of blanks, through opposed glue applicators **2709** which may apply a suitable adhesive to flaps and then move the blank above shoe device **2130**. The moving apparatus may then move the blank downwards through the shoe device **2130** causing the flaps to be folded and they can be held within the shoe for a sufficient time to allow the glue to set. Thereafter continued movement downwards can push the blank clear of the shoe device **2130** and then suction cups can release the blank which can then fall onto support plate **2703**. Thereafter the blank can be moved for example by a blow-off nozzle discharging high pressure air (under control of PLC **132** through a valve device interposed in pressurized air hoses) to discharge the blank to chute **2750** for transfer to a discharge conveyor.

It will be appreciated that by making a relatively small number of changes to the components of the system, the system can be altered from being able to process blanks for open top cartons to being able to process blanks that can be turned into open top trays. Examples of other blanks that may be processed, cartons that may be formed are illustrated in FIGS. 47, 48 and 49 and include blanks for wrap around half slotted cases (HSC) and HSC blanks, as well as blanks for a wrap around RSC.

Turning now to FIG. 58, an order fulfillment system generally designated **1000** may include several components including an order fulfillment processor **1300**, and corresponding sets of case formers **1100A**, **1100B** and **1100C**, case loaders **1400A**, **1400B** and **1400C** and case sealers **1500A**, **1500B** and **1500C**. A plurality of customer order devices **1200A**, **1200B** and **1200C** may be provided that may be linked with order fulfillment processor **1300**. Customer order device **1200A** may for example be a telephone that

may be capable of communication with a call center **1250**. Call center **1250** may be adapted to receive orders from customer operating customer order device **1200A** and then by virtue of call center software, a call center operator may input an order for one or more products that may be communicated by a communication link to order fulfillment processor **1300**. Customer order devices **1200B** and **1200C** may for example be personal computing devices including mobile phones, personal computers, etc. that may be capable of direct communication such as by communication over a wireless and/or land-based communication network with order fulfillment processor **1300**. This network may, for example, an IPv4, IPv6, X.25, IPX compliant or similar network. Thus, this network may be the public Internet. Through operation of appropriate software on the customer order devices **1200B**, **1200C** and order fulfillment processor **1300**, the customer order devices **1200B**, **1200C** may be adapted to input an order for one or more products into order fulfillment processor **1300**. For example, customer order devices **1200B** and **1200C** may be adapted to execute a suitable HyperText Transfer Protocol (HTTP)-enabled browser to access data and services provided by an HTTP server application executed by order fulfillment processor **1300**, and thereby input orders for one or more products into order fulfillment processor **1300**.

Order fulfillment processor **1300** may be a mainframe computer, a server, or other computing device capable of processing customer orders received directly or indirectly from customer order devices **1200A-C**. Order fulfillment processor **1300** may include a database that includes information that may be stored in a suitable memory therein including information relating to: (a) information/details of all products that may be ordered by a customer through system **1000** including one or more characteristics of each product such as the physical volume occupied by the space and/or the actual physical dimensions (e.g. height, width, length, and/or diameter) of each product (such as the dimensions of the box in which one or more items is held), optionally the weight of each product, and further optionally product codes associated with each product, such as a Universal Product Codes (UPC) or, if the product is a book, an International Standard Book Number (ISBN); (b) information/details of each of a plurality of types/sizes/configurations of cases/case blanks that can or are being used in system **1000** to package one or more products ordered by a customer including the dimensions of each type of case/case blank; (c) information/details of each case former (e.g., case formers **1100A-C**), including information/details of the cases that each case former is capable of forming (such as the type, size and/or configuration), and optionally when a case former includes multiple magazines, as detailed below, the type, size and/or configuration of case blank provided in each of those magazines and the corresponding type, size and/or configuration of case that can be formed from each type of case blank, and further optionally the quantity of case blanks provided in each of those magazines; (d) information/details about each customer including the name of the entity and shipping address to which an order fulfilled by system **1000** is to be shipped and (e) information/details about where each product is located in a product storage facility such as a warehouse building holding products that may be ordered.

As noted, order fulfillment processor **1300** may also include an HTTP server application adapted to provide database information to customer order devices **1200B** and **1200C**, and to receive orders from customer order devices **1200B** and **1200C**. Some or all of the aforementioned

information/details may be input into order fulfillment processor **1300** manually by an operator of system **1000**. Additionally or alternatively with respect to information/details of each available case may be updated periodically or on an ongoing basis. PLC **132** of each carton former **1100A-1100C** may during operation, be adapted to monitor the status of the case blanks in its magazine(s) and provide information relating to that status to order fulfillment processor **1300**. In this way, order fulfillment processor **1300** may be continually be provided with up-to-date information on available case blanks that are in the magazines of each of the carton formers.

Order fulfillment processor **1300** may also include a product packaging utility/product packaging software module that identifies a suitable type of case (or types of cases) for packaging the products in an order placed by a customer from a plurality of available cases. An example of such a product packaging utility is disclosed in U.S. Pat. No. 6,876,958 to Chowdhury et al., issued to assignee New Breed Corporation on Apr. 5, 2005 (hereinafter, "Chowdhury"), the contents of which is hereby incorporated by reference herein in its entirety. In particular, Chowdhury's product packaging utility processes each order placed by a customer to automatically identify, from available case types/sizes/configurations, a type/size/configuration of suitable case (or cases) suitable for packaging the products in the order. Chowdhury's product packaging utility identifies/determine suitable case(s) according to an algorithm/function that accesses and uses one or more electronically-stored characteristics of each product in the order (e.g., dimensions, weight, etc.) and one or more electronically-stored characteristics of available case types (e.g., dimensions, size, configuration, type, maximum volume that can be held, maximum weight that can be held, etc.). This algorithm identifies suitable cases such that a minimum number of cases and the smallest size cases suitable for packaging the products in the order may be provided. Thus, identification of suitable case types/sizes/configurations can be optimized to provide an optimal case type/size/configuration which minimizes packaging material used and to minimize empty space in cases, and a case identified as suitable may be referred to as an "optimal" case. It will be appreciated that identification of suitable case types/sizes/configurations may also be identified or optimized according other pre-defined criteria. The case identification algorithm of Chowdhury's product packaging utility may also take into account other factors and constraints such as, e.g., the availability of each type/size/configuration of case, the maximum fill ratio of each type/size/configuration of case, the maximum number of products that can be placed into each type/size/configuration of case, and whether certain products are pre-packaged together and therefore must be placed in the same case. Thus, when order fulfillment processor **1300** includes a product packaging utility such as Chowdhury's product packaging utility, order fulfillment processor **1300** may process a customer order for specific products by accessing information in it memory and utilizing an algorithm/function to identify a suitable case (or cases) for packaging those products from a plurality of available cases.

It should be noted that the size of the case may be the overall internal available volume of the case in which items may be held. The size may also be the specific dimensions of the case. The type of case may include the reference to what material the blanks is made from (e.g. paperboard or corrugated cardboard). Its configuration may an indication

of it being a top opening case which is generally cuboid in shape when closed, or another configuration such as a regular slotted case, etc.

Chowdhury's product packaging utility may also generate, for each case of a particular type/size/configuration identified to fulfil an order, a packing list indicating the order in which each of the products is to be preferably placed into the case, as well as placement information indicating where each product is to be preferable placed in the case. For example, this placement information may be expressed using coordinates (e.g., 0, 0, 0) in a coordinates system defined for the case and/or descriptors of locations in the case (e.g., front, right hand side, second layer, etc.). Thus, when order fulfillment processor **1300** includes a product packaging utility such as Chowdhury's product packaging utility, order fulfillment processor **1300** may generate a packing list and/or placement information for each identified case. Order fulfillment processor **1300** may also generate a diagram illustrating a desired optimal physical arrangement of the products in each case. Such a diagram may be readily generated using placement coordinates for each product, as provided by Chowdhury's product packaging utility.

For each case of a particular type identified to fulfil an order, order fulfillment processor **1300** may also be configured to be able to select one of case formers **1100A**, **1100B** or **1100C** to form a suitable case of the type/size/configuration identified by order fulfillment processor **1300**. Order fulfillment processor **1300** may access and use information stored in its memory regarding the suitability of the case formers to handle an identified suitable case. For example, suitability of a case former may be determined by order fulfillment processor **1300** based on stored information regarding whether the case former includes magazines designated to hold the types/size/configuration of case blanks required forming the identified case. Suitability of a case former may also be determined based on stored information regarding the quantity of the required type/size/configuration of case blank in a magazine of the case former. Such quantities may be measured using suitable sensors placed at each case former, and updated during operation. Alternatively, order fulfillment processor **1300** may simply select a case former randomly or according to a pre-defined sequence.

Once a suitable case former (e.g., one of case formers **1100A**, **1100B** or **1100C**) has been selected, order fulfillment processor **1300** may generate a Fulfillment Order data structure (e.g. a file, object, message or the like) containing information for/instructions to the case former to form and label a required case. A generated Fulfillment Order data structure may be communicated by a communication link to the PLC of one of the case formers **1100A**, **1100B** or **1100C**.

The Fulfillment Order data structure may include indicators indicating (i) the type/size/configuration of case determined by the product packaging utility that is required to be formed and labelled by the case former **1100A**, **1100B**, **1100C**; (ii) the particular magazine of the case former containing case blanks for forming the required suitable case; (iii) a list of the particular product(s) from the customer order being fulfilled that are required to be loaded into the required case once formed, optionally identified by associated product codes and optionally arranged in the order in which the products should be loaded into the case once formed; (iv) optionally information such as packing list or a diagram illustrating/specifying a desired optimal physical arrangement of the products in loading the case; (v) optionally the location in the storage facility/warehouse building of each particular product from the customer order being

fulfilled; and (vi) customer shipping information for that case indicating the destination name and address for that case. In some cases, the Fulfillment Order data structure may include information for multiple cases to be handled by the selected case former.

A Fulfillment Order data structure may be received and processed by the PLC of the case former to which the data structure is sent. In particular, the PLC of the case former processes the Fulfillment Order data structure to identify a requested type/size/configuration of case (or cases) to be formed, the particular magazine of the case former containing case blanks for forming each required case, and the contents of the label (or labels) to be applied. Once a required suitable case and the particular magazine containing case blanks for forming the required suitable case have been identified, the PLC of the selected case former **1100A**, **1100B** or **1100C** can then cause a suitable case blank to be formed into the requested type/size/configuration of case and labelled, as further described hereinafter.

Optionally, the data structure may be stored in memory of the PLC of the case former or in memory of order fulfillment processor **1300** for later retrieval when the order is picked and packed, as described below.

Once the case has been formed and labelled for a particular customer product order, it may then be physically transferred to a respective case loader generally designated **1400A**, **1400B** or **1400C**. In some embodiments, the formed and labelled case can be picked up by a person (referred to herein as an Order Fulfillment Picker or "OFP") who may be in a product storage facility (e.g. a warehouse building) filled with the products handled by order fulfillment system **1000**. OFP may have or carry a label scanner device **1407** (see FIG. **62B**) which may include a scanner **1411** and an interconnected display device **1409**. Examples of suitable label scanning devices that could be employed include the model LT5020H made by Worth Data Inc. (Santa Cruz, Calif., USA).

Label scanning device **1407** may be a bar code reader adapted to scan and derive information from the label or labels applied to the case. Optionally, label scanning device **1407** may be connected to one or other of the PLC of the case former or order fulfillment processor **1300** by a communication link. In such instance, some or all of the information for a case may be retrieved by label scanning device **1407** from the PLC of the case former or from order fulfillment processor **1300** using a case identifier encoded in bar codes on the label(s) applied to the case.

The OFP may for example scan the bar codes on the label(s) on the case which may enable the OFP to identify the particular products that are to be loaded into that case. Optionally, scanning these bar codes may also enable the OFP to identify where the particular products are located in the warehouse building. The OFP may then load the case into a cart **1413** (FIG. **62B**) and then proceed to locate the products in the warehouse and fill the case with those products, possibly in the order listed by the scanning device **1407**. Optionally, a packaging arrangement diagram (such as the diagram of FIG. **61**) either illustrated on the label on the case, or optionally displayed on a device such as the label scanner, if available, may be provided to and used by the OFP to load the case in a desired optimal manner. An example of a packaging arrangement diagram that can be utilized to load a case is illustrated in FIG. **61**. A case, formed from a blank, and having dimensions of width W, height H and Length L, can be loaded as shown with items (i.e. products) numbered 1 to 6 arranged in a particular arrangement and may also include some additional dunnage

or packing material (e.g. bubble wrap type material) that may be inserted by an OFP to maintain the stability and integrity of the items in the packaging arrangement during shipping to the customer.

In other embodiments, one or more of the case loaders **1400A**, **1400B**, **1400C** may include automated equipment such as one or more robotic systems instead or in addition to an OFP.

Turning now to FIGS. **53** to **57**, case former **1100** (representative of each of case formers **1100A-C**) may comprise the same or substantially the same components as carton forming system **100** as described above, except where differences are hereinafter described. Like in carton forming system **100**, the structural/mechanical components of carton former **1100** may be made from any suitable materials. Case former **1100** is particularly useful as part of a customer order fulfillment system **1000** that may fulfil product orders placed or initiated by customers as described above. However, carton former **1100** may also be used in other applications.

As an alternate to a magazine like magazine **110** in carton forming system **100** as described above, case former **1100** may include or utilize a plurality of magazines such as magazines **M1-M16**. Magazines **M1-M16** may each contain one or more stacks of product packaging, such as case blanks which each may generally be like blanks **111** processed by system **100**, with at least some of the magazines **M1-M16** containing different types/sizes and/or configurations of packaging/case blanks to other magazines. The size, configurations and types of case blanks (and the cases that can be formed therefrom) can vary to provide a range of case sizes, configurations and types that can be automatically processed by carton former **1100** without the need for any manual intervention to modify any components of the case former **1100**. PLC **132** of case former **1100** may be programmed such that the particular dimensions/overall size/configuration (e.g. such as regular slotted carton or "RSC")/type of each of the blanks held in each one of the magazines **M1-M16** is stored in the memory of the PLC **132**.

It should also be noted that case former **1100A**, **1100B**, and **1100C** may each be configured with magazines having a different set/selection of sizes/configurations/types of case blanks from that of the other magazines, so that each of the carton formers **1100A**, **1100B**, **1100C** are operable to process different cases. Case formers **1100A**, **1100B**, and **1100C** may be configured with magazines such that they collectively process a pre-defined set of case blanks types that provides a range of case sizes, configurations and types.

Each magazine **M1-M16** may have its own blank transfer apparatus that may each include a transversely oriented magazine conveyor **1203(1)** to **1203(16)** respectively. Each conveyor **1203(1)** to **1203(16)** (referred to generically as a magazine conveyor **1203**) may be controlled by PLC **132** of its carton former **1100**, such that a stack of blanks in each magazine **M1-M16** may be moved to a position adjacent a longitudinally oriented, central case blank in-feed conveyor **1204**. Each magazine **M1-M16** may have a transfer apparatus under the control of PLC **132** that is operable to extract and move a blank from a stack in the magazine **M1-M16** adjacent to in-feed conveyor **1204** and feed it onto central in-feed conveyor **1204** to that it may be transported to be labelled as described hereinafter, and also folded and sealed in a manner like that described above in connection with system **100**.

With reference now to FIG. **54A**, by way of representative example of the construction of a magazine, magazine conveyor **1203(1)** may include a frame **1215** that supports five, generally parallel, and spaced continuous belts **1213** that

may be made of any suitable flexible material such as Ropanyl. The belts 1213 may each extend between rotatable idler wheels 1221 mounted on a freely rotatable shaft and rotatable drive wheels 1223. Drive wheels 1223 may be mounted for rotation with and to a common drive shaft 1225 of a servo motor 1219 that may be interconnected via and in communication with a servo drive to the PLC 132 of the case former 1100. Conveyor belts 1213 may each have an upper belt portion that together may support one or more stacks of blanks 1211 thereon. PLC 132 may give an instruction (such as by order fulfillment processor 1300) to form a case, and if required, PLC 132 may cause upper belt portion of belt 214 to move towards in-feed conveyor 1204 by operation of servo motor 1219 rotating drive wheels 1223. In this way belt 214 can, if necessary, move a stack of blanks 1211 to a position adjacent to the in-feed conveyor 1204.

Positioned proximate the end of each magazine conveyor 1203 adjacent in-feed conveyor 1204 may be a vertically and longitudinally oriented plate 1230. Each plate 1230 may be supported by a plurality of plate support members 1235 that may be part of frame 1215. A lower longitudinally extending edge 1233 of plate 1230 may be positioned so that only the bottom blank in a stack of blanks (i.e. the blank that is immediately above the upper portions of the belts) can pass through a slot provided beneath lower edge 1233 of plate 1230 and the horizontal plane formed by the upper surface of the upper portions of the belts 1213. In this way, a slot 1231 can be provided that can permit a single blank at a time from the bottom of the stack to be pushed transversely through the slot and onto the in-feed conveyor 1204.

A pushing mechanism may be provided to respond to signals from PLC 132 of the case former to push a blank in a magazine from the bottom of the stack through the slot 1204 and onto in-feed conveyor 1204. The pushing mechanism may be any suitable type of device and may for example include a plurality of lugs 1217 located in the spaces between belts 1213. The lugs may be driven in a cyclical path by a common type crank mechanism (not shown) that may include a common pneumatic or hydraulic cylinder with a piston controlled by PLC 132 by activating appropriate valves to suitably control the flow of pressurized air/hydraulic fluid to the cylinder. The cylinder may have a piston arm attached to a longitudinally oriented bar member that may be mounted for rotation. The crank mechanism may be configured to provide a path for the lugs 1217 that commences in a position behind the bottom blank in a stack; then moves transversely between the belts 1213 while engaging the rear side edge of the bottom blank thereby pushing the bottom blank through the slot 1231. Once the crank mechanism reaches the end of the stroke, the lugs 1271 will descend downwards beneath the stack of blanks and move transversely in an opposite direction back to the starting position, while at the same time not engaging the next bottom blank on the stack and passing beneath the stack. The path returns the lugs 1217 back to the start position so that when signalled by PLC 132 to load another blank onto conveyor 1204, the operation can be repeated.

In summary, PLC 132 can thus control motor 1219 and thus the movement of each conveyor 1203 as well as the movement of the lugs 1281, and thus is able to selectively move and transfer a single blank at a time onto in-feed conveyor 1204 from any one of magazines M1 to M16

Therefore, unlike in system 100 where a stack of case blanks may be fed to the alignment conveyor 206 by in-feed conveyor 204, in system 1000 separate individual case blanks may be fed in series and longitudinally by in-feed conveyor 1204 to alignment conveyor 1206. The particular

sequence/order of case blanks that are placed onto in-feed conveyor 1204 of each case former 1100A-C may be determined and selected by PLC 132 such that case blanks may arrive at alignment conveyor 1206 in such a desired manner in which it is desired to process the blanks at least within case former 1100.

Further, each PLC 132 may maintain in its memory records of case blanks that have been placed onto in-feed conveyor 1204, to be formed and labelled. Each record may include information received by PLC 132 from order fulfillment processor 1300 (e.g., by way of the Fulfillment Order data structure) for a particular case blank to be formed and labelled. For example, this information may include the type/size/configuration of the case blank and the label information to be applied to the case blank. A new record can be added each time a request for a new case is received from order fulfillment processor 1300 and optionally records can be removed once a case has been formed and labelled. Thus, such records may be organized and maintained in sequence in the memory of PLC 132 using a conventional shift registering technique. In this way, the record for the next case blank scheduled to arrive at alignment conveyor 1206 may be provided at the output of the shift registers as that case blank arrives, and the type/configuration/size of that case blank and the label information for that case blank may be determined from the provided output.

Once transferred from in-feed conveyor 1204 to alignment conveyor 1206, the alignment conveyor 1206 may then under the control of PLC 132 move each blank sequentially to the pick up location. The pick up location may in part be determined by the front edge of each blank abutting the surfaces of a pair of spaced vertical plates 1218 (FIG. 57) as they are moved longitudinally downstream by alignment conveyor 1206.

Conveyor 1204 may be constructed substantially like conveyor 204 may include a pair of spaced conveyor belt 214 that may be driven by a suitable motor such as a DC motor or a variable frequency drive motor. The motor may be DC motor and may be controlled through a DC motor drive (such as are all sold by Oriental under model AXH-5100-KC-30) by PLC 132.

Conveyor belts 214 may have an upper belt portion supported on rollers (not shown). PLC 132 can as required cause upper portions of belts 214 to move longitudinally downstream towards alignment conveyor 1206. In this way belts 214 can move a series of spaced apart case blanks longitudinally downstream. PLC 132 can control the motor driving conveyor 1204 through the motor drive and thus conveyor 1204 can be operated to move and transfer a series of blanks obtained from multiple magazine of magazines M1 to M16 towards and for transfer to the alignment conveyor 1206.

Blank alignment conveyor 1206, like alignment conveyor 206, may also include a series of transversely oriented rollers 1208 that may be mounted for free rotating movement to a lower portion of the magazine frame 202. A conveyor belt 1216 may be driven by a motor that and have a corresponding motor drive. This motor and motor drive for conveyor 1206 may also be controlled by PLC 132. Belt 1216 may be provided with an upper belt portion supported on rollers 1208 and upon which one or more case blanks may be supported. Conveyor belt 1216 may be operated to move each case blank in turn further longitudinally until the front face of the blank abuts with a generally planar, vertically and transversely oriented inward facing surface of upstanding spaced plates 1218 so that each case blank is in turn placed into the pick up position.

Conveyor belt **1214** of conveyor **1204** and conveyor belt **1216** of conveyor **1206** may be made from any suitable material such as for example Ropanyl.

A sensor (not shown) such as an electronic eye model 42KL-D1LB-F4 made by ALLEN BRADLEY, may be located within the horizontal gap between belt **1214** and belt **1216**. The sensor may be positioned and operable to detect the presence of the front edge of a blank as each blank in turn begins to move over the gap between conveyor belt **1214** and conveyor belt **1216**. Upon detecting the front edge, sensor may send a digital signal to PLC **132** signalling that a particular blank (the size/configuration/type of which PLC **132** is aware) has moved to a position where conveyor **1206** can start to move. PLC **132** can then cause the motor for conveyor **1206** to be activated such that the top portion of belt **1216** starts to move the blank downstream. In this way, there can be a “hand-off” of each blank from in-feed conveyor **1204** to alignment conveyor **1206**.

Once the rear edge of each blank passes the sensor, a signal may be sent to PLC **132** which can then respond by sending a signal to shut down the motor driving belt **1214** of conveyor **1204**. Conveyor **1204** is then in a condition to await a further signal thereafter to feed the next blank in the series of blanks on the conveyor **1204** to alignment conveyor **1206**. Meanwhile alignment conveyor **1206** can be operated to move the blank placed thereon to the pick up location.

The presence of a blank on alignment conveyor **1206** at the pick up location may be detected by another sensor that may be the same type of sensor as sensors **240** and **242**. The sensor may detect the presence of the front edge of a blank at the pick up position and may send a digital signal to PLC **132** signalling that a blank is at the pick up position. At the pick up position, the blank may also be centred longitudinally by a pair of moveable longitudinally oriented side wall guides **1201** and **1202**.

Each blank may be suitably longitudinally and transversely positioned and oriented in a pick up position for proper engagement by both a labelling device and by one of the erector heads like erector heads **120a**, **120b** of system **100**. Side guide walls **1201** and **1202** may be mounted to on tracks to a lower portion of a lower frame and both may be oriented generally vertically and may extend longitudinally for substantially the full length of alignment conveyor **1206**. The side guide walls **1201**, **1202** may be mounted in a similar manner as side walls **200**, **201** in system **100**.

A drive mechanism may be provided to drive each of side walls **1201** and **1202** on respective tracks. For side walls **1201** and **1202**, one or more drive mechanisms that are in electronic communication with PLC **132** can be provided. By way of example, a servo motor with gear head may be provided and be in electronic communication with PLC **132** through a servo drive. Examples that could be used are servo motor MPL-B1530U-VJ42AA made by ALLEN BRADLEY, in combination with servo drive 2094-BC01-MP5-S also made by ALLEN BRADLEY and gear head AE050-010 FOR MPL-A1520 made by Apex.

Like in carton forming system **100**, in case former **1100** lead screw rods may be inter-connected to servo motor/gear heads. Lead screw rods may pass through nuts, which may be fixedly secured to plates. Plates may be interconnected to spaced, generally vertically oriented bar members. Bar members may be interconnected to support frame (not shown) forming part of side walls. By activating servo motor/gear heads, the rotation of the servo may rotate the screw rods. As rods passes through nuts, the nuts can be moved laterally either inwards or outwards, thereby causing walls **1201**, **1202** to slide on tracks inwards or outwards

depending upon the direction of rotation of screw rods. Encoders may be provided within or in association with servo drive motors and the encoders may rotate in relation to the rotation of the respective drive shaft of the servo drives. The encoders may be in communication with, and provide signals to the servo drives which can then pass on the information to PLC **132**. Thus, PLC **132** may be able to determine the longitudinal position of the screw rods in real time and thus the transverse position of side walls **1201**, **1202** and can operate the servo drives to adjust the position of the side walls **1201**, **1202**. The particular type of encoder that may be used is known as an “absolute” encoder. Thus once the encoders are calibrated so that a position of each the screw rod is “zeroed”, then even if power is lost to system **1000**, the encoders can maintain their zero position calibrations. With the transverse alignment mechanism of side guides walls **1201**, **1202** in abutment with the left and right side edges of the blank, guide walls can ensure the proper positioning of the datum line when the blanks are flattened is properly transversely aligned to be labelled by labelling device **1281** (only shown in FIG. **57**) and to be picked up by erector heads **120** of system **1100** and moved through folding and sealing apparatus **130**, as described above to achieve proper folding and sealing of the carton/case blank.

Optionally, PLC **132** may verify that the type/size/configuration of the case blank at the pick up location matches the expected case blank. For example, the top surface of each case blank may include a bar code identifying its type/size/configuration, and this bar code may be read at the pick up location by a suitably positioned bar code reader. The type/size/configuration of the case blank read from this bar code may be compared to the expected type/size/configuration of case blank, which may be determined from a record of the next scheduled case blank stored in memory of the PLC, as described above. Verification is successful when there is a match. When there is not a match, PLC **132** may issue a signal requesting manual operator intervention.

As indicated above, each case blank in each magazine may be generally initially formed and provided in a flattened tubular configuration such as by way of example is shown in FIGS. **10A-10E**. Each case blank has a height dimension “H”; a length dimension “L”; and a major panel length “Q” (see FIG. **10B**). The PLC of each case former **1100** may maintain in its memory each of these three dimensions for a case blank to be processed by case former **1100**, and using these stored dimensions, the PLC can determine the necessary positions and/or movements of at least some of the components forming system **100**, including the path of movement of erector heads **120a**, **120b** as the erector heads move and cycle through their processing sequences.

In this regard, for each case blank in each of magazines **M1** to **M16**, PLC **132** may have the information necessary to adequately process each case blank selected.

As was indicated above in relation to a representative case blank as shown in FIG. **11**, each case blank in each magazine may be designated with a first datum line “W1” that passes through the mid-point of the fold line between panel D and flap K, and the mid-point of the fold line between panel B and flap J. This datum line W1 may be determined by PLC for blank to be processed, based on the dimensions H, L and Q of the blanks stored by the PLC or obtained by the PLC. Blank **111** may also be designated with a second datum line “W2” that may be determined by PLC **132** and which passes along and is generally parallel to the fold line between panel D and flap K, and the mid-point of the fold line between panel A and flap F. Datum W1 will be parallel to Datum W2. PLC **132** may also determine the relative position of the

bottom of the erected case for the cases in each magazine as this will be aligned with a vertical datum plane passing through Datum W1 and Datum W2. Aligning the position datum W2 and of the datum plane with other components in case former 1100 will ensure that the case is properly positioned during processing. Also, the vertical distance R between datum W1 and the datum line W2 may be calculated by PLC. This can ensure that PLC knows where it needs to position the erector head so that top panel A, and accordingly, datum W1 are properly positioned throughout the processing of the blank by case former 1100.

Case former 1100 is able to track and modify the position of each case blank as it is being processed, and in particular the vertical position of the datum line W1 of the case blank as the case blank moves longitudinally through case former 1100 and as various components of case former 1100 engage the case blank during its movements. This will ensure that the case blank being processed is appropriately positioned relative to the system components so that the system components engage the case blank at the correct position on the blank during processing of the blank. For blanks that may be configured differently than blank 111, suitable adjustments may possibly be required to the dimensions and datums maintained by PLC 132 in order for carton former 1100 to be able to process a particular size/configuration/type of blank.

Labelling device 1281 may be mounted to the frame of carton/case former 1100 in the vicinity of alignment conveyor 1206. For example (although not depicted as such in the FIG. 57 for simplicity) labelling device 1281 may be mounted to a frame portion of carton former 1100 generally above where a case blank is located when the case blank is in the pick up location. Labelling device 1281 may be operable to print and apply one or more labels to one or more panels, preferably upward facing panels, of a blank located at the pick up location. Labelling device 1281 may be any suitable device such as the PLS-500 label application system made by Paragon Labeling Systems Inc. (White Bear Lake, Minn., USA) in conjunction with an integral print engine, such as a Lt408 print engine or a S84 Series print engine (e.g., model nos. S8408, S8412, or S8424) made by SATO America, Inc. (Charlotte, N.C., USA). While in some embodiments a labelling device may apply a physically separate label to the case or case blank, in other embodiments the labelling device may apply printing to the case or case blank without providing the printing on a physically separate label.

As noted above, the label or labels applied to an upward facing panel(s) of each blank by labelling device 1281 may be specifically configured for that particular blank and may contain various types of information relating to an order of products to be fulfilled for the case to be formed from that particular blank. The label or labels may contain information providing certain order information including types of products to be loaded into the case to be formed from that blank, optionally including product codes of those products, the customer to whom the case is to be shipped and the customer's address, as well as a case packing diagram that may be used by a product picker or filler in packing the case in a desired configuration with the products, and the locations in the warehouse building of the products. The label or labels may also contain a unique case identifier. Some or all of the information may be provided in bar code format, which a bar code reading device handled by an OFP may use to access the information from the label(s) once applied to the case blank.

The label is thus preferably printed and applied to the case blank while it is in a flattened configuration at the pick up location and prior to being erected and bottom sealed. This may make the label application process more reliable and provides the case with a unique identification.

Examples of the format of labels 1283a, 1283b that might be applied by labelling device 1281 are illustrated in FIGS. 59 and 60 respectively.

Once the label has been applied by labelling device 1281, case former 1100 may then proceed to erect and seal the case from the case blank in a manner like system 100 described above. It will be appreciated that PLC 132 may be in communication with the labelling device 1281 and can provide instructions for the printing and application of a suitable label or label(s) for the particular blank that is at the pick up location.

Once the case has been formed and sealed to form an erected case that is partially sealed and may be in a configuration such as shown in FIG. 16, the case may then be delivered from the discharge conveyor 117 (see for example FIG. 8) and be placed onto an accumulation conveyor that may be part of the respective case loader such as case loader 1400A, 1400B or 1400C associated with the particular carton former 1100A-C which formed the case.

The OFP may initiate the order picking process by picking an empty case from an accumulation conveyor and place the case onto an OFP cart 1413 (FIG. 62B) that can be moved around the warehouse where the products handled by system 1100 are located. Multiple cases may be picked and placed onto the OFP cart at the same time. The OFP will scan the appropriate bar code label on each case. This provides the OFP with all of the information necessary to pick and pack the order as predetermined by order fulfillment processor 1300. In some instances, some of all of this information may be retrieved by the OFP from the PLC 132 of the case former or from order fulfillment processor 1300 using a unique case identifier encoded in the bar code label.

With all of the order information available to the OFP the OFP picks and packs the order of products directly into the case. The OFP may verify that the correct products are being packed into the case by bar code reading both the product and the case during the picking and packing operation, e.g., by comparing the UPC/ISBN provided by the bar code on the label(s) applied to the case with the UPC/ISBN on the product being packed.

Once the order (or part order for a particular case) has been completed by the OFP, such that all products for that case are loaded into the case, the case is directed to a final case sealing apparatus 1500A-C. For example the OFP may place the loaded case with all products loaded therein onto a predetermined Random Top Case Seal (RTCS) in-feed conveyor that may feed the case to a suitable top sealing device. The RTCS may be adapted to read a label on the case placed by labelling device 1281 or otherwise located on the case, and as a result of information provided by the bar code the RTCS may automatically adjust the sealing components of the device so that it may close and seal the top of the case. The finished case may then be conveyed into the central case distribution system for further sorting and processing. An example of the type of suitable RTSC apparatus that could be employed as part of system 1000 is the random case sealer made by Marq Packaging Systems.

In operation of system 1000, each one of a plurality of customers may use a customer order device such as devices 1200A, 1200B and 1200C, including possibly accessing call center 1250. Through operation of appropriate software on the order placement devices 1200A-C, the order placement

devices **1200A-C** may communicate directly or indirectly with order placement processor **1300** to so that multiple orders may be placed by customers, each orders being for one or more products, into order fulfillment processor **1300**.

Order fulfillment processor **1300** may process the customer orders received directly or indirectly from customer order devices **1200A-C**. Order fulfillment processor **1300** may for each order utilize its database that includes information that may be stored therein including information relating to: (a) details of all products that may be ordered by a customer through system **1000** including the actual physical dimensions of each product (such as the dimensions of the item package in which an item is packaged), optionally the weight of each product, and further optionally product codes associated with each product; (b) details of each of a plurality of types/sizes/configurations of cases/case blanks that can be used in system **1000** to package one or more products ordered by a customer including the dimensions of each case/case blank; (c) details of each case former (e.g., case formers **1100A-C**), including the types of cases that each case former is capable of forming, and optionally when a case former includes multiple magazines, the type of case blank provided in each of those magazines and the corresponding type of case that can be formed from each type of case blank, and further optionally the quantity of case blanks provided in each of those magazines; (d) information about each customer including the name of the entity and shipping address to which an order fulfilled by system **1000** is to be shipped; and (e) information about where each product is located in a warehouse building housing products that may be ordered.

Order fulfillment processor **1300** may also for each order use the product packaging utility to identify a suitable case and possibly an optimum case (e.g. having particular type/size/configuration) from the packaging suite of a limited and predetermined number of types/sizes/configurations of cases. Thus, when each order for specific products is input into order fulfillment processor **1300**, the product packaging utility can determine the optimal case or cases that can be used to package the products for each order (e.g. determine the least number of cases and/or the smallest size of cases that are required to package all the products in the customer order).

Order fulfillment processor **1300** may then for each order, generate a Fulfillment Order data structure that may be communicated by a communication link to the PLC of one of the case formers **1100A**, **1100B** or **1100C**. The order fulfillment processor **1300** may have determined to which of the case formers to send each Fulfillment Order data structure either randomly, or based on availability and/or suitability to handle the case type/size/configuration determined for a particular customer order. The Fulfillment Order data structure may include information including (i) the type/size/configuration of case determined by the product packaging utility that is required to be formed and labelled by the case former **1100A**, **1100B**, **1100C**; (ii) the particular magazine of the case former containing case blanks for forming the required type/size/configuration of case; (iii) a list of the particular product(s) from the customer order being fulfilled that are required to be loaded into the required case once formed, optionally arranged in the order in which the products should be loaded into the case once formed; (iv) optionally a diagram illustrating a desired optimal physical arrangement of the product(s) in loading the case; (v) optionally the location in the warehouse building of each particular product from the customer order being fulfilled;

and (vi) customer shipping information for that case indicating the destination name and address for that case.

Each Fulfillment Order data structure may then be received and processed by the PLC **132** of the case former to which the data structure is sent. In particular, the PLC of the case former processes the Fulfillment Order data structure to identify the type/size/configuration of case (or cases) required, the particular magazine of the case former containing case blanks for forming each required type/size/configuration of case, and the contents of the label (or labels) to be applied. Once a required type/size/configuration of case and the particular magazine containing case blanks for forming the required type/size/configuration of case have been identified, the PLC of the case former causes a case blank from the identified magazine to be formed and labelled, generally as outlined above.

In particular, the PLC activates the appropriate conveyor of magazine conveyors **1203(1)** to **1203(16)**, corresponding to the identified magazine, if required to move a stack of case blanks of the identified type adjacent to in-feed conveyor **1204**. The transfer apparatus may, under the control of PLC **132**, then transfer the desired case blank from the identified magazine to the in-feed conveyor **1204**. The in-feed conveyor **1204** will then under the control of PLC **132** move that case blank longitudinally and then when signalled by PLC **132** to do so, transfer it to the alignment conveyor **1206**.

Alignment conveyor **1206** also under the control of PLC **132** may then move the case blank to the pick up location and PLC **132** may then also cause the side walls **1201**, **1202**, to transversely align the case blank so that it is at the correct pick up position. PLC **132** may then cause labelling device **1281** to apply one or more labels like labels **1283a**, **1283b** to one or more upward facing surfaces of the panels of the case blank. PLC **132** may then cause the carton forming components of the carton former including an erecting head **120**, to be moved by the movement sub-system to pick up the case blank from the pick up position and erect and partially seal the case from the case blank. PLC **132** may on an ongoing basis, as each case blank is being processed, cause any adjustments in components of folding and sealing apparatus **130** to be made to accommodate each case blank at they are processed.

Once the case has been formed and labelled for a particular customer product order, it may then be physically transferred to a respective case loader generally designated **1400A**, **1400B** or **1400C**. The formed and labelled case can be picked up by the OFP in a warehouse building filled with the products. The OFP can scan and derive information from the label or labels applied to the case to identify the particular products that are to be loaded into that case and the OFP may then proceed to locate the products in the warehouse and fill the case with those products, possibly in the order listed by the scanning device. A packaging arrangement diagram either illustrated on the label on the case, or optionally displayed on a device such as the label scanner, if available, may be used by the OFP to load the case in the desired optimal manner.

Once the order (or part order for a particular case) has been completed by the OFP, such that all products for that case are loaded into the case, the case is directed to a final case sealing apparatus **1500A-C**. The OFP may place the loaded case with all products loaded therein onto a predetermined Random Top Case Seal (RTCS) in-feed conveyor that may feed the case to a suitable top sealing device. The RTCS may read a label on the case placed by labelling device **1281** or otherwise located on the case, and as a result

of information provided by the bar code the RTCS may automatically adjust the sealing components of the device so that it may close and seal the top of the case. The finished case may then be conveyed into the central case distribution system for further sorting and processing.

Various modifications are also possible in some embodiments. By way of example only, instead of providing for magazine conveyors **1203(1)** to **1203(N)** for magazines **M1** to **M(N)**, it may be possible to provide for a robotic system which could extract case blanks as demanded by PLC **132** from any one of a stack of case blanks in each of the magazines. The robotic system could either place a particular case blank that may be required on an in-feed conveyor. In other embodiments, the in-feed conveyor could be eliminated and the robotic system may place each case blanks that is required at the pick up position.

Of course, the above described embodiments are intended to be illustrative only and in no way limiting. The described embodiments of carrying out the invention are susceptible to many modifications of form, arrangement of parts, details and order of operation. The invention, rather, is intended to encompass all such modification within its scope, as defined by the claims.

When introducing elements of the present invention or the embodiments thereof, the articles “a,” “an,” “the” and “said” are intended to mean that there are one or more of the elements. The terms “comprising,” “including,” and “having” are intended to be inclusive and mean that there may be additional elements other than the listed elements.

The invention claimed is:

1. A method for use in fulfilling an order, said order comprising a plurality of products, said method comprising: receiving order data identifying a customer and said plurality of products; retrieving from a database, stored dimensions of each of said plurality of products; based on said dimensions, determining a size for a case for use in packing at least some products of said plurality of products and a packing order and arrangement for said some products in said case; identifying from amongst a plurality of magazines holding blanks for cases of different sizes, a magazine holding blanks for said case; feeding a blank from said magazine to a labeller and a case former; at said labeller, labeling said blank, or said case, with a label which includes at least a portion of said order data and data indicating said packing order and said arrangement for said some products; at said case former, erecting said blank into said case so as to leave said case open at a top; scanning said label to identify said some products and said packing order and said arrangement for said some products in said case; based on said packing order, translating said case in a warehouse warehousing said some products to a first location of a first to be packed product of said some products; at said first location, based on said arrangement, packing said first to be packed product in said case at a first position in said case; based on said packing order, translating said case in said warehouse to a second location of a second to be packed product of said some products, said second location being a different location than said first location;

at said second location, based on said arrangement, packing said second to be packed product in said case at a second position in said case;

repeating said translating and said packing for each remaining one of said some products; and sealing said top of said case.

2. A method as claimed in claim **1**, further comprising forwarding information to said labeller and wherein said case blank is labelled by said labeller prior to or during the erection of said blank into said case.

3. A method as claimed in claim **1**, wherein said method further comprises generating a case packaging spatial arrangement for said some products in said case based on dimensions of the case and dimensions of each product of said some products.

4. A method as claimed in claim **1**, wherein said blank is a tubular blank comprising a plurality of panels and flaps interconnected to provide a generally flattened tubular configuration, where said plurality of panels comprise a first panel and a second panel interconnected to said first panel, said second panel being rotatable relative to said first panel, and wherein said erecting said blank into said case comprises:

(a) orienting said blank in a generally flat orientation with said first and second panels being generally parallel to each other;

(b) engaging said first panel;

(c) engaging said second panel and rotating a second panel of said blank from said first orientation to a second orientation that is generally orthogonal to said first panel to open said tubular blank.

5. The method of claim **1** wherein said plurality of products comprise said some products and remaining products, wherein said size is a first size, said case is a first case, said magazine is a first magazine, said blank is a first blank, and said label is a first label, and wherein said method further comprises:

based on said dimensions, determining a size for a second case for use in packing said remaining products and a packing order and arrangement for said remaining products in said second case;

identifying from amongst said plurality of magazines, a second magazine holding blanks for said second case; feeding a second blank from said second magazine to said labeller and said case former;

at said labeller, labeling said second blank, or said second case, with a second label which includes at least a portion of said order data and data indicating said packing order and said arrangement for said remaining products;

at said case former, erecting said second blank into said second case so as to leave said second case open at a top;

scanning said second label to identify said remaining products and said packing order and said arrangement for said remaining products in said second case;

based on said packing order for said remaining products, translating said second case in said warehouse to a location of a first to be packed product of said remaining products;

at said location of said first to be packed product of said remaining products, based on said arrangement for said remaining products, packing said first to be packed product of said remaining products in said second case at a first position in said second case;

based on said packing order for said remaining products, translating said second case in said warehouse to a

49

location of a second to be packed product of said remaining products, said location of a second to be packed product of said remaining products being a different location than said location of said first to be packed product of said remaining products;

at said location of a second to be packed product of said remaining products, based on said arrangement for said remaining products, packing said second to be packed product of said remaining products in said second case at a second position in said second case; repeating said translating and said packing for each remaining one of said remaining products; and sealing said top of said second case.

6. A method as claimed in claim 1, wherein said plurality of magazines hold blanks for cases having a plurality of sizes and wherein said determining said size for said case for holding said some products is determined as a function of said dimensions for each product of said some products and dimensions of each of said plurality of sizes.

7. A method as claimed in claim 6, wherein said size is determined by a computing device operating a product packaging utility configured to determine said size.

8. A method as claimed in claim 1, wherein magazines of said plurality of magazines are arrayed on opposite sides of an in-feed conveyor that feeds to said labeller and said case former and wherein said feeding comprises feeding said blank from said magazine to said in-feed conveyor and from said in-feed conveyor to said labeller and case former.

9. The method of claim 8,

wherein said magazine is a first magazine, said plurality of magazines comprise a first plurality of magazines including said first magazine at a first side of said in-feed conveyor and a second plurality of magazines including a second magazine at a second side of said in-feed conveyor opposite to said first side, said first magazine holding a plurality of case blanks for forming cases of said size, said size being a first size, said second magazine holds a plurality of case blanks for forming cases of a second size, said second size being different from said first size.

10. A method as claimed in claim 1 wherein said labelling with a label which includes data indicating said packing order and said arrangement for said some products comprises labelling with a label including a case packaging diagram and wherein said scanning said label is scanning said label by a picker to obtain said case packaging diagram and wherein said picker packs each product of said some products into said case using said case packaging diagram.

11. A method as claimed in claim 10, wherein said case packaging diagram is provided in an electronic format that is reviewed by said picker using a scanning device adapted to scan said at least one label and display said case packaging diagram.

12. A method as claimed in claim 1, wherein at least one physically separate label is applied by said labeller and wherein said at least one physically separate label contains information providing a list of said some products.

13. A method as claimed in claim 12, wherein said at least one physically separate label contains information relating to the location of each product of said some products in said warehouse.

14. A method as claimed in claim 12, wherein said scanning is scanning said label with a label scanner, and wherein said scanning causes a shipping destination and a list of each product of said some products to be retrieved from a memory.

50

15. A system for fulfilling an order, said order comprising a plurality of products, said system comprising:

an order fulfillment processor;

a database;

a plurality of magazines holding a plurality of case blanks for cases of different sizes such that any given magazine holds case blanks for cases of a single size;

a feeder, former, and labeler operable to feed a case blank from any of said plurality of magazines erect a case from said case blank, and label said case blank or said case;

at least one case loader;

said order fulfillment processor operatively connected to said feeder, former and labeller, and said case loader;

wherein said order fulfillment processor is operable to (a) receive an order comprising data identifying a customer and said plurality of products; (b) retrieve from said database, stored dimensions of each of said plurality of products; (c) based on said dimensions, determine a size for a case for use in packing at least some products of said plurality of products and a packing order and arrangement for said some products in said case; (c) forward information identifying said size, said some products, and a packing order and arrangement for said some products in said case to said feeder former, and labeller;

wherein said feeder, former, and labeller is operable to: (i) receive said information; (ii) select a particular magazine of said plurality of magazines holding blanks for cases of said size; and (iii) feed a particular case blank from said particular magazine, erect said case from said particular case blank so as to leave said case open at a top and label one of said particular case blank and said case with a label indicating said some products and said packing order and arrangement for said some products;

and wherein said at least one case loader is operable to:

scan said label to identify said some products and said packing order and said arrangement for said some products in said case;

based on said packing order, translate said case in a warehouse warehousing said some products to a first location of a first to be packed product of said some products;

at said first location, based on said arrangement, pack said first to be packed product in said case at a first position in said case;

based on said packing order, translate said case in said warehouse to a second location of a second to be packed product of said some products, said second location being a different location than said first location;

at said second location, based on said arrangement, pack said second to be packed product in said case at a second position in said case; and

repeat said translating and said packing for each remaining one of said some products.

16. A system as claimed in claim 15, wherein said feeder, former and labeller is operable for forming said case from a plurality of tubular blanks, each tubular blank comprising a plurality of panels and flaps interconnected to provide a generally flattened tubular configuration, wherein said plurality of panels comprise a first panel, and a second panel interconnected to said first panel, said second panel being rotatable relative to said first panel, said feeder, former, and labeller comprises:

a first engagement device for engaging said first panel of said tubular blank;

51

a second engagement device for engaging said second panel of said tubular blank, said second engagement device being located on a panel rotating apparatus operable to rotate said second panel of each said tubular bank from a first orientation wherein said first panel is generally parallel to said first panel, to a second orientation wherein second panel is oriented at an angle to said first panel, such that said tubular blank may be reconfigured from a generally flattened configuration to an open configuration.

17. The system of claim 15 wherein said feeder, former, and labeler comprises an in-feed conveyor, a case erector, and a labelling device, said in-feed conveyor feeding to said case erector and labelling device and wherein magazines of said plurality of magazines are arrayed on opposite sides of said in-feed conveyor.

18. The system of claim 17 wherein said particular magazine is a first magazine, said plurality of magazines comprise a first plurality of magazines including said first magazine at a first side of said in-feed conveyor and a second plurality of magazines including a second magazine at a second side of said in-feed conveyor opposite to said first side, said first magazine holding a plurality of case blanks for forming cases of said size, said size being a first size, said second magazine holding a plurality of case blanks for forming cases of a second size, said second size being different from said first size.

52

19. A method for use in fulfilling a request for a plurality of products from a customer comprising:
determining from a label of a case with an open top specific products for said case, said specific products being ones of said plurality of products, a packing order for said specific products in said case, and an arrangement for said specific products in said case;
based on said packing order, translating said case in a warehouse warehousing said specific products to a first location of a first to be packed product of said specific products;
at said first location, based on said arrangement, packing said first to be packed product in said case at a first position in said case;
based on said packing order, translating said case in said warehouse to a second location of a second to be packed product of said identified products, said second location being a different location than said first location;
at said second location, based on said arrangement, packing said second to be packed product in said case at a second position in said case;
repeating said translating and said packing for each remaining one of said specific products; and
sealing said top of said case.

* * * * *